

Autumn Run

Town of Mukwonago, Wisconsin

Preliminary

Storm Water Management Plan

Prepared by:



Trio Engineering LLC

4100 N. Calhoun Road
Brookfield, Wisconsin 53005
Contact: Josh Pudelko, P.E.
Telephone: (262) 790-1480
Email: info@trioeng.com

Sound Stormwater Design LLC

Contact: Jayme Sisel, P.E.
Telephone: (414) 286-4739
Email: jayme.sisel@soundstormwater.com

May 13, 2026

TABLE OF CONTENTS

Introduction	1
Owner/ Developer.....	1
Design Requirements.....	1
Analysis Overview.....	2
Pre-Development Watershed Description.....	2
Post-Development Site Drainage Description	3
Stormwater Detention Basin Design & Summary.....	4
Peak Discharge Summaries.....	5
Water Quality	6
Infiltration.....	6
Conclusion.....	6

APPENDICES

FIGURES

APPENDIX A	Pre-Development Hydrologic Analysis
APPENDIX B	Post-Development Hydrologic Analysis
APPENDIX C	Treatment Analysis / WinSLAMM
APPENDIX D	Infiltration Analysis / WinSLAMM
APPENDIX E	Soil Survey & Soil Boring Logs

Introduction

“Autumn Run” is a proposed 17-lot residential subdivision on a 54.23-acre parcel located at W310 S8471 County Road I, in the Town of Mukwonago, Waukesha County, Wisconsin.

This report documents the design computations for existing and proposed conditions and presents a plan for stormwater management that meets the requirements of the Town of Mukwonago and the Wisconsin Department of Natural Resources (WDNR).

Owner/ Developer

The owner, developer, and responsible entity for installation and maintenance of the storm water management practices:

Ryan’s Buying LLC
P.O. Box 277
Eagle, Wisconsin 53119
Contact: Ryan Janssen
Phone: (414) 736-3066
Email: ryan@ryansbuying.com

Design Requirements

The following design standards have been used to develop the stormwater management plan for the “Autumn Run” development:

- Waukesha County Chapter 14, Article VIII, Stormwater Management & Erosion Control Ordinance
- Wisconsin Department of Natural Resources (WDNR): Technical Standards, NR151, and NR216
- Summary of Town of Mukwonago design requirements:
 - Peak Discharge:
 - The peak flow discharge rates of stormwater runoff from the site under the post-development site conditions shall not exceed the rates under the pre-development conditions for the 1, 2, 10, and 100-yr, 24-hr design storms.
 - Water Quality (Total Suspended Solids): Reduce to the maximum extent practicable the total suspended solids load by 80% for new development sites, based on an average annual rainfall, as compared to no runoff management controls.
 - Infiltration: For low imperviousness developments:
 - Infiltrate sufficient runoff volume so that the post-development infiltration volume shall be at least 90% of the pre-development infiltration volume, based on an average annual rainfall.
 - No more than 1% of the project site is required as an effective infiltration area.

Analysis Overview

The Stormwater Management Plan for the “Autumn Run” development has been designed in accordance with the Town of Mukwonago stormwater management requirements and all applicable state requirements. Existing and proposed stormwater runoff conditions for the site were analyzed for: runoff volume, peak volume, discharge, detention basin storage capacity required, outlet structure and storm sewer system requirements. The software package used for modeling and analysis was HydroCAD Version 10.20 software by HydroCAD Software Solutions. HydroCAD uses NRCS methods to generate runoff and pond routing hydrographs. The model’s capabilities include modeling simple drainage basins, combining hydrographs to determine runoff and storage requirements, and detention basin and outlet structure sizing.

MSE3 rainfall distributions were used for modeling the 1, 2, 10 and 100-year, 24-hour storm events. The corresponding rainfall data used for modeling was taken from the National Oceanic and Atmospheric Administration (NOAA) Atlas 14 Precipitation Frequency Tables for Wisconsin Counties and is shown in the following table.

TABLE 1
Design Rainfall Values

Storm Recurrence Interval	24-hour Rainfall Depths
1-year	2.4 inches
2-year	2.7 inches
10-year	3.81 inches
100-year	6.18 inches

Soil types for the site were determined from the NRCS Soil Survey Maps for Waukesha County and from soil boring logs prepared by Butler Engineering, Inc. The Soil Survey identifies the soils at the site as mostly Type B soils (Miami sandy loam) with limited areas of Type C soils (Fox loam). The soil boring logs indicated the soils as generally sandy loam underlain by sandy clay loam, gravely sandy loam, and gravely loamy sand. Groundwater was encountered at depths of 9 feet in boring P1, 7 feet in boring P5 and 8 feet in boring P6. No water was observed at boring locations P2, P3 or P4.

Based on this, a hydrologic soil group Type B was used to determine runoff curve numbers for the site. Refer to Appendix E for details.

Pre-Development Watershed Description

The existing site is occupied by a farmstead and is mostly comprised of agricultural fields with limited areas of woodlands. Surface drainage for the site is split with the northern portion draining towards an on-site kettle, the eastern portion draining towards culvert crossings at County Road I, and the southern portion draining offsite into backyards of the adjacent subdivision. The entire site is ultimately tributary to the Fox River.

Pre-development land cover types, topography, drainage subareas, and flow paths are shown on Figure 1. The following tables summarize the results of the stormwater model for pre-development conditions. A schematic plan of the hydrological analyses and detailed hydrological computations for pre-development conditions are included in Appendix A.

TABLE 2
Pre-Development Site Conditions

Subarea or Junction	Description	Total Area (acres)	Impervious Area (acres)	Time of Conc. (min.)	Peak Flow Rate (cfs)			
					1-year	2-year	10-year	100-year
N1	North Subarea (offsite)	17.78	0.60	19	4.41	7.01	19.61	54.65
1D	Depression	-	-	-	0.30	1.32	9.77	34.74
N2	North Subarea (offsite)	7.05	0.50	9	3.73	5.49	13.21	33.31
2D	Depression	-	-	-	0.63	1.37	4.62	27.07
N3	North Subarea (offsite)	26.92	1.12	28	8.02	11.71	28.83	74.17
3D	Depression	-	-	-	7.55	12.56	31.75	80.42
N4	North Subarea	20.91	0.81	9	6.34	10.65	31.20	87.97
4K	Kettle (on site)	-	-	-	0.00	0.00	0.00	0.00
W1	West Subarea	9.75	0.04	14	3.69	5.56	14.17	37.09
5D	Depression	-	-	-	0.00	0.00	0.42	12.44
E1	East Subarea	6.32	0.30	11	2.04	3.29	9.17	25.27
6D	Depression	-	-	-	0.00	0.00	0.00	2.37
E2	East Subarea	9.09	0.40	8	1.97	3.67	12.26	36.77
7D	Depression	-	-	-	1.95	3.29	6.63	34.22
E3	East Subarea	5.01	0.38	15	0.83	1.50	5.06	15.53
E4	East Subarea	1.60	0.08	13	0.18	0.36	1.43	4.75
E5	East Subarea	0.94	0.00	9	0.02	0.06	0.52	2.46
S1	South Subarea	15.50	0.12	18	4.51	6.99	18.58	50.45
4K	Discharge to Kettle 4K	82.41	3.07	-	10.24	16.86	42.94	125.67
1L	Discharge to County Road I	22.96	1.16	-	2.66	5.08	13.53	55.38
2L	Discharge South	15.50	0.12	-	4.51	6.99	18.58	50.45

Post-Development Site Drainage Description

The proposed development plan includes the construction of seventeen (17) single-family residential lots. Calculations for the subdivision are based on a 6,000 square-foot impervious footprint per lot. General assumptions were made for the types of impervious development per lot and are as follows: 1,500 sq-ft drives, 3,600 sq-ft roof, and 900 sq-ft sidewalks/patios.

The proposed plan will disturb approximately 36-acres and will result in a net increase in impervious area of approximately 3.72 acres. Stormwater management for the proposed development will be provided by 4 bio-infiltration basins.

Figure 2 shows the proposed land cover, grading, drainage subarea boundaries, flow paths, and proposed site and stormwater management improvements. The following table summarizes the results of the hydrologic analyses for post-development conditions. A schematic plan of the hydrological analyses and detailed hydrological computations for post-development conditions are included in Appendix B.

TABLE 3
Post-Development Site Conditions

Subarea or Junction	Description	Total Area (acres)	Impervious Area (acres)	Time of Conc. (min.)	Peak Flow Rate (cfs)			
					1-year	2-year	10-year	100-year
N1	North Subarea (offsite)	17.78	0.60	19	4.41	7.01	19.61	54.65
1D	Depression	-	-	-	0.30	1.32	9.77	34.74
N2	North Subarea (offsite)	7.05	0.50	9	3.73	5.49	13.21	33.31
2D	Depression	-	-	-	0.63	1.37	4.62	27.07
N3	North Subarea (offsite)	26.92	1.12	28	8.02	11.71	28.83	74.17
3D	Depression	-	-	-	7.55	12.56	31.75	80.42
N4	North Subarea	20.70	0.91	11	3.15	6.13	22.55	71.35
4K	Kettle (on site)	-	-	-	0.00	0.00	0.00	0.00
W1	West Subarea	6.44	0.12	10	0.79	1.65	6.71	22.07
5D	Depression	-	-	-	0.00	0.00	0.00	1.78
E1	East Subarea	12.90	1.64	11	3.58	6.00	17.66	50.14
6B	Basin	-	-	-	0.01	0.11	1.05	4.03
E2	East Subarea	5.96	0.40	10	0.94	1.86	6.84	21.49
7D	Depression	-	-	-	0.94	1.86	5.35	21.22
E3	East Subarea	4.28	0.66	11	1.41	2.26	6.29	17.29
8B	Basin	-	-	-	0.21	0.41	1.35	2.50
E4	East Subarea	0.95	0.16	6	0.41	0.66	1.76	4.73
E5	East Subarea	1.13	0.38	12	0.74	1.02	2.24	5.29
S1	South Subarea	11.34	1.32	15	2.26	3.90	12.28	36.34
9B	Basin	-	-	-	0.00	0.00	0.00	3.36
S2	South Subarea	3.47	0.05	14	0.38	0.75	2.99	9.93
10B	Basin	-	-	-	0.00	0.00	0.00	0.56
S3	South Subarea	1.95	0.21	9	0.50	0.87	2.72	7.91
4K	Discharge to Kettle 4K	78.89	3.25	-	9.45	16.12	42.06	116.12
1L	Discharge to County Road I	25.22	3.24	-	1.94	3.31	9.15	30.98
2L	Discharge South	16.76	1.58	-	0.50	0.87	2.72	7.91

Stormwater Detention Basin Design & Summary

The development plan proposes four bio-infiltration basins as the primary means of stormwater management for the site. In conformance with WDNR requirements, the basins have been designed with 4:1 side slopes on the berms and 10-foot top of berm widths.

The following table summarizes the detention system routing analysis for post development conditions. Details of the stormwater management facilities are included in Appendix B.

TABLE 4
Routing Analysis Summary

Proposed Basin 6B				
System Details: Bottom elevation = 958.25 Top of berm elevation = 961.25		Outlet Control: 0.11 inch/hour native infiltration rate (1002 Table 2) 12-inch diameter outlet pipe at I.E. 958.50 10-foot spillway at elevation 960.25		
	1-year Storm	2-year Storm	10-year Storm	100-year Storm
Peak Inflow (cfs)	3.58	6.00	17.66	50.14
Peak Outflow (cfs)	0.01	0.11	1.05	4.03
Max Water Surface Elev.	958.56	958.66	959.03	960.14
Max Storage Volume (ac-ft)	0.22	0.30	0.60	1.54
Proposed Basin 8B				
System Details: Bottom elevation = 972.00 Top of berm elevation = 976.00		Outlet Control: 0.11 inch/hour native infiltration rate (1002 Table 2) 8-inch diameter outlet pipe at I.E. 972.25 10-foot spillway at elevation 975.00		
	1-year Storm	2-year Storm	10-year Storm	100-year Storm
Peak Inflow (cfs)	1.41	2.26	6.29	17.29
Peak Outflow (cfs)	0.21	0.41	1.35	2.50
Max Water Surface Elev.	972.51	972.62	973.23	974.80
Max Storage Volume (ac-ft)	0.05	0.06	0.14	0.44
Proposed Basin 9B				
System Details: Bottom elevation = 962.00 Top of berm elevation = 965.00		Outlet Control: 0.50 inch/hour native infiltration rate (1002 Table 2) 15-inch diameter interconnection pipe at I.E. 962.00 36-inch diameter horizontal grate at elev. 963.75 12-inch diameter outlet pipe at I.E. 962.00 10-foot spillway at elevation 964.00		
	1-year Storm	2-year Storm	10-year Storm	100-year Storm
Peak Inflow (cfs)	2.26	3.90	12.28	36.34
Peak Outflow (cfs)	0.00	0.00	0.00	3.36
Max Water Surface Elev.	962.19	962.32	962.85	963.98
Max Storage Volume (ac-ft)	0.10	0.16	0.44	1.11
Proposed Basin 10B				
System Details: Bottom elevation = 962.00 Top of berm elevation = 965.00		Outlet Control: 0.50 inch/hour native infiltration rate (1002 Table 2) 15-inch diameter interconnection pipe at I.E. 962.00 10-foot spillway at elevation 964.00		
	1-year Storm	2-year Storm	10-year Storm	100-year Storm
Peak Inflow (cfs)	0.38	0.76	3.05	11.45
Peak Outflow (cfs)	0.00	0.00	0.00	0.56
Max Water Surface Elev.	962.04	962.15	962.85	963.95
Max Storage Volume (ac-ft)	0.01	0.04	0.26	0.66

Peak Discharge Summaries

The Town of Mukwonago requires post-development peak discharge rates to be no greater than pre-development discharge rates for the 1, 2, 10, and 100-yr, 24-hr design storms. The following table compares the results of the analysis from a peak discharge standpoint.

**TABLE 5
Comparison of Peak Discharge**

<i>Discharge to Existing Kettle (4K)</i>			
	Pre-Development		Post-Development
1-year	10.24 cfs	>	9.45 cfs
2-year	16.86 cfs	>	16.12 cfs
10-year	42.94 cfs	>	42.06 cfs
100-year	125.67 cfs	>	116.12 cfs
<i>Discharge to County Road I (Link 1L)</i>			
	Pre-Development		Post-Development
1-year	2.66 cfs	>	1.94 cfs
2-year	5.08 cfs	>	3.31 cfs
10-year	13.53 cfs	>	9.15 cfs
100-year	55.38 cfs	>	30.98 cfs
<i>Discharge South (Link 2L)</i>			
	Pre-Development		Post-Development
1-year	4.51 cfs	>	0.50 cfs
2-year	6.99 cfs	>	0.87 cfs
10-year	18.58 cfs	>	2.72 cfs
100-year	50.45 cfs	>	7.91 cfs

Water Quality

The Town of Mukwonago requires new development sites to be designed to remove 80 percent of TSS, based on an average annual rainfall as compared to no runoff management controls. Stormwater quality was analyzed using SLAMM Version 10.5.0 software, developed by Robert Pitt and John Voorhees.

The results of the SLAMM analysis indicate that approximately 81.3 percent of TSS will be removed from stormwater as a result of the proposed bio-infiltration basins, grass swales, and disconnection of roofs and patios. In addition, approximately 82.6 percent of total phosphorus will be removed from the development site. Detailed computations are included in Appendix C.

Infiltration

The Town of Mukwonago requires low imperviousness developments to infiltrate sufficient runoff volume so that the post-development infiltration volume is at least 90% of the pre-development infiltration volume, based on an average annual rainfall. However, no more than 1% of the project site is required as an effective infiltration area.

Four bio-infiltration basins were incorporated into the development plan to meet infiltration performance standards for the proposed subdivision. Design infiltration rates for the site were taken from Table 2 of WDNR Technical Standard 1002, Site Evaluation for Stormwater Infiltration. Infiltration calculations were analyzed using winSLAMM to determine runoff volumes for both pre-development and post-development conditions. The results of the winSLAMM analysis indicate that

the site will infiltrate over 100 percent of the pre-development infiltration volume. Detailed computations are included in Appendix D.

Conclusion

The proposed development will maintain compliance with the Town of Mukwonago and the WDNR's requirements for control of stormwater quantity, quality, and infiltration. We request, on behalf of the owner, approval of this Stormwater Management Plan to allow for construction of the Autumn Run subdivision development.

Prepared by:

SOUND STORMWATER DESIGN LLC

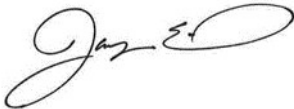
A handwritten signature in black ink, appearing to read "Jayme Sisel". The signature is fluid and cursive, with a large loop at the end.

Jayme Sisel, P.E.

FIGURES

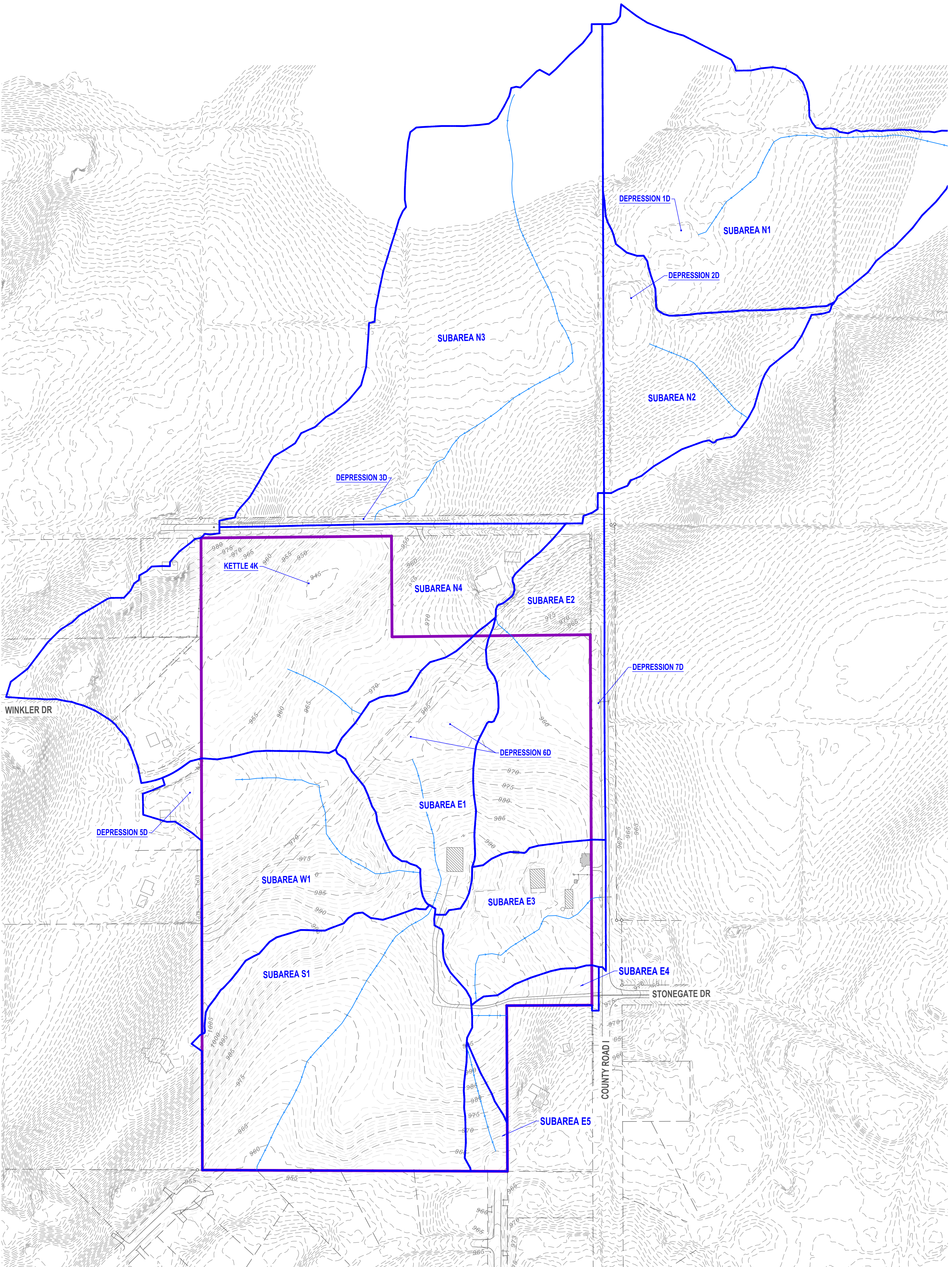

PRE-DEVELOPMENT CONDITIONS

AUTUMN RUN COUNTY ROAD I

TOWN OF MUKWONAGO, WISCONSIN

LEGEND

- -DRAINAGE BASIN BOUNDARY
- > -Tc LINE

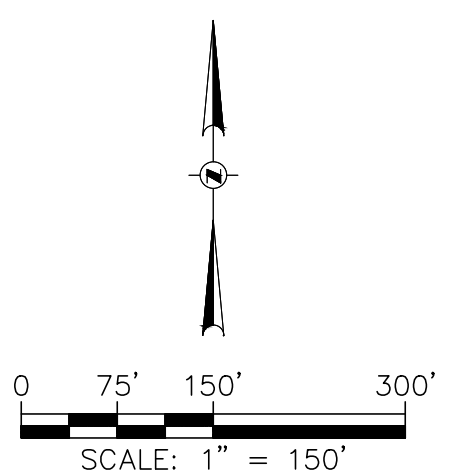
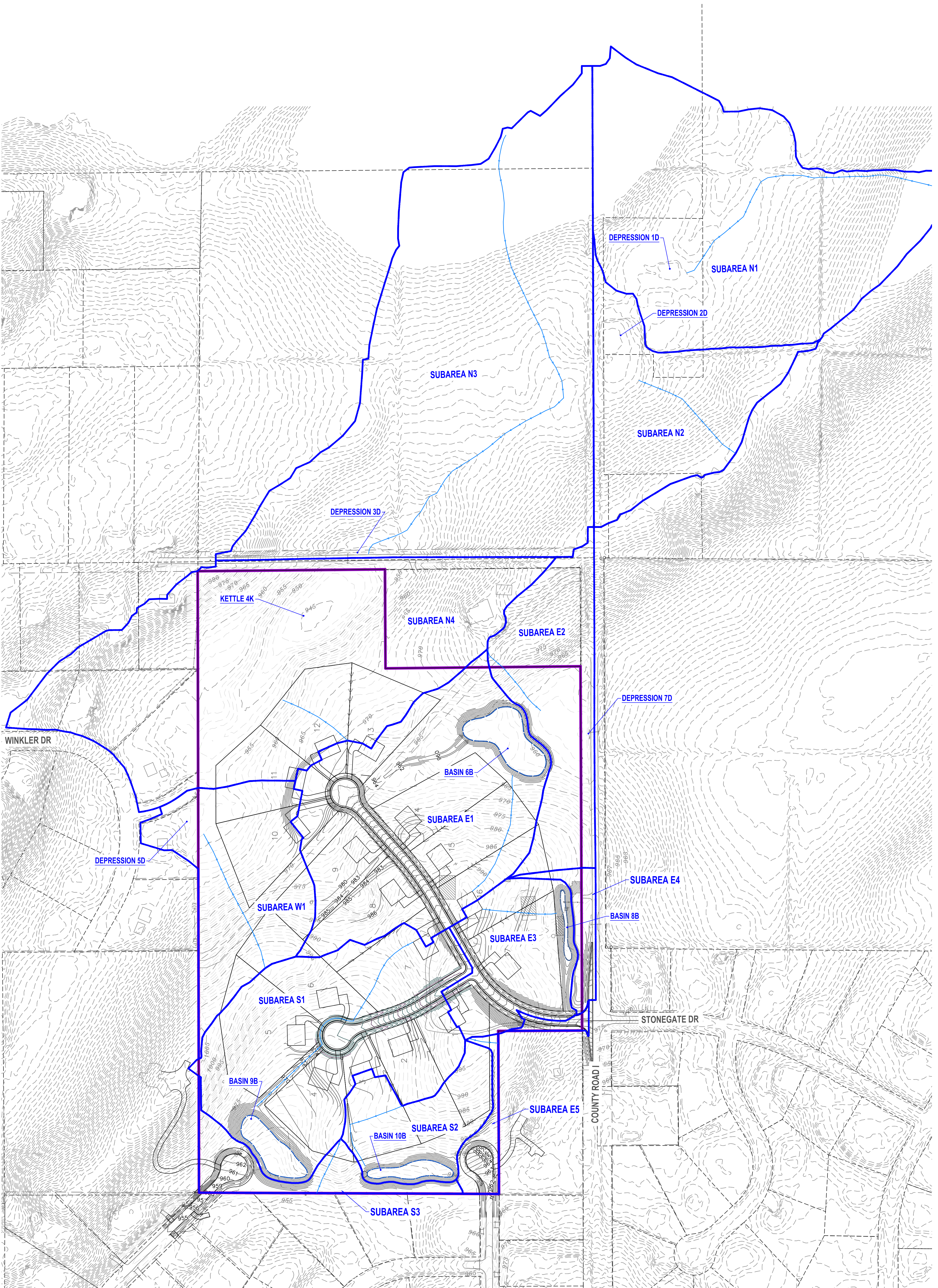

FIGURE 1



POST-DEVELOPMENT CONDITIONS

AUTUMN RUN
COUNTY ROAD I

TOWN OF MUKWONAGO, WISCONSIN

LEGEND

- - DRAINAGE BASIN BOUNDARY
- > - T_c LINE

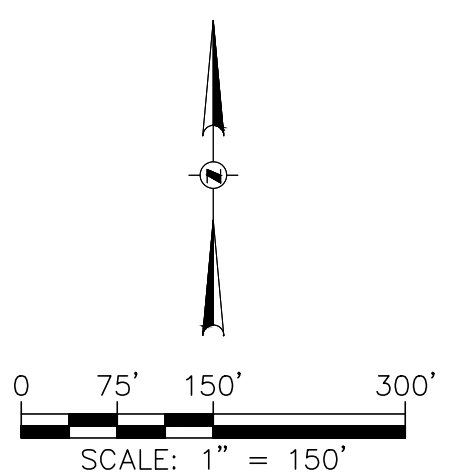
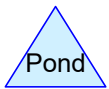
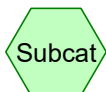
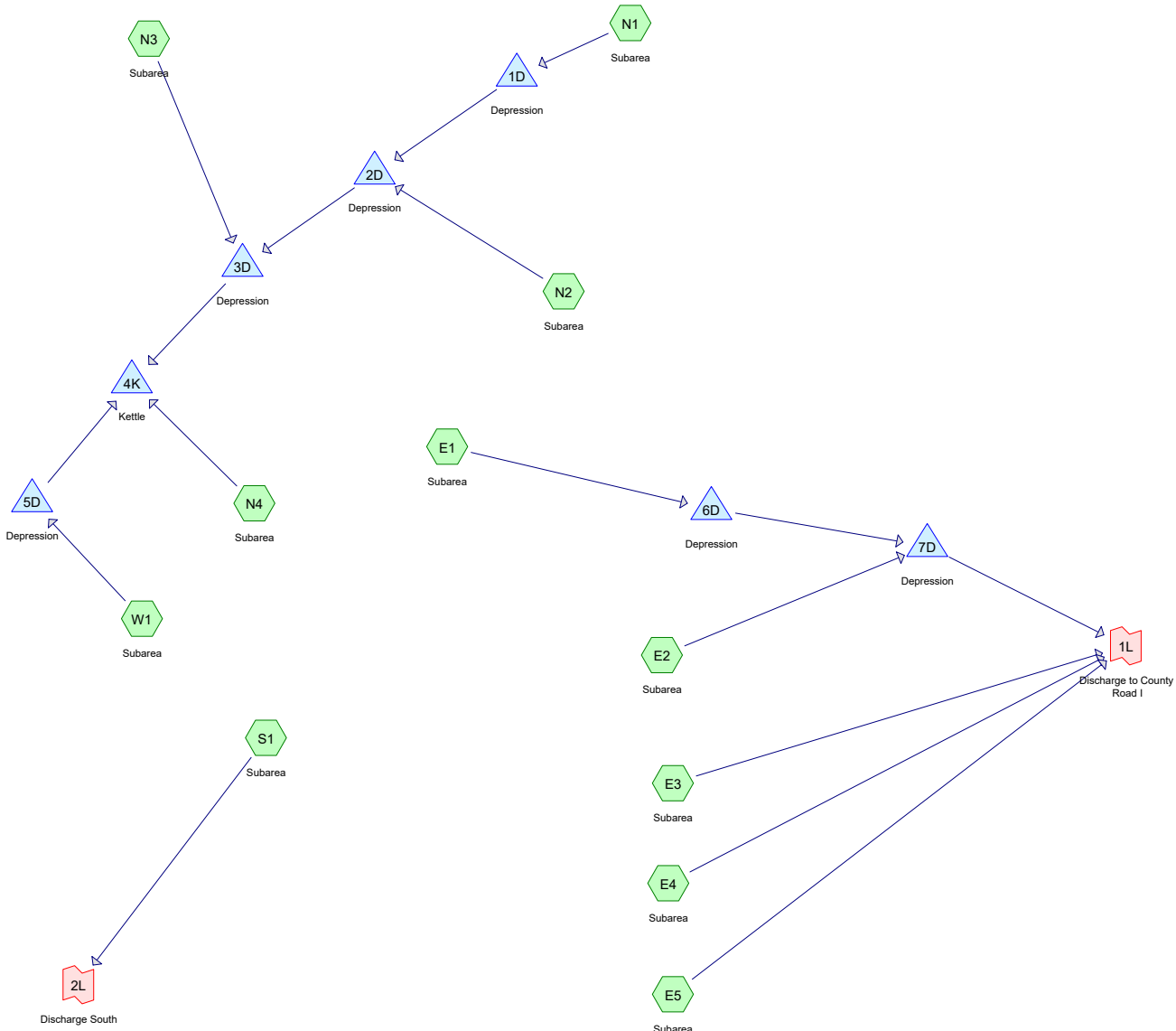

FIGURE 2

APPENDIX A

Pre-Development Hydrologic Analysis



Routing Diagram for Existing_2026-002
 Prepared by Sound Stormwater Design, Printed 5/12/2026
 HydroCAD® 10.20-4c s/n 11025 © 2024 HydroCAD Software Solutions LLC

Existing_2026-002

Prepared by Sound Stormwater Design

HydroCAD® 10.20-4c s/n 11025 © 2024 HydroCAD Software Solutions LLC

Printed 5/12/2026

Page 2

Rainfall Events Listing (selected events)

Event#	Event Name	Storm Type	Curve	Mode	Duration (hours)	B/B	Depth (inches)	AMC
1	1 yr	MSE 24-hr	3	Default	24.00	1	2.40	2
2	2 yr	MSE 24-hr	3	Default	24.00	1	2.70	2
3	10 yr	MSE 24-hr	3	Default	24.00	1	3.81	2
4	100 yr	MSE 24-hr	3	Default	24.00	1	6.18	2

Existing_2026-002

Prepared by Sound Stormwater Design

HydroCAD® 10.20-4c s/n 11025 © 2024 HydroCAD Software Solutions LLC

Printed 5/12/2026

Page 3

Area Listing (all nodes)

Area (acres)	CN	Description (subcatchment-numbers)
80.550	69	cropland (E1, E2, E3, N1, N2, N3, N4, S1, W1)
32.170	61	grass (E1, E2, E3, E4, E5, N1, N2, N3, N4, S1, W1)
4.350	98	impervious (E1, E2, E3, E4, N1, N2, N3, N4, S1, W1)
3.800	55	woodland (E1, E2, E4, E5, S1)
120.870	67	TOTAL AREA

Time span=0.00-24.00 hrs, dt=0.01 hrs, 2401 points
Runoff by SCS TR-20 method, UH=SCS, Weighted-CN
Reach routing by Dyn-Stor-Ind method - Pond routing by Dyn-Stor-Ind method

SubcatchmentE1: Subarea Runoff Area=6.320 ac 4.75% Impervious Runoff Depth>0.32"
Flow Length=510' Slope=0.0700 '/' Tc=11.0 min CN=67 Runoff=2.04 cfs 0.166 af

SubcatchmentE2: Subarea Runoff Area=9.090 ac 4.40% Impervious Runoff Depth>0.24"
Flow Length=280' Slope=0.0800 '/' Tc=8.0 min CN=64 Runoff=1.97 cfs 0.178 af

SubcatchmentE3: Subarea Runoff Area=5.010 ac 7.58% Impervious Runoff Depth>0.24"
Flow Length=645' Slope=0.0400 '/' Tc=14.6 min CN=64 Runoff=0.83 cfs 0.098 af

SubcatchmentE4: Subarea Runoff Area=1.600 ac 5.00% Impervious Runoff Depth>0.19"
Flow Length=115' Slope=0.0300 '/' Tc=13.3 min CN=62 Runoff=0.18 cfs 0.025 af

SubcatchmentE5: Subarea Runoff Area=0.940 ac 0.00% Impervious Runoff Depth>0.08"
Flow Length=360' Slope=0.1000 '/' Tc=9.1 min CN=56 Runoff=0.02 cfs 0.006 af

SubcatchmentN1: Subarea Runoff Area=17.780 ac 3.37% Impervious Runoff Depth>0.31"
Flow Length=1,065' Tc=18.6 min CN=67 Runoff=4.41 cfs 0.467 af

SubcatchmentN2: Subarea Runoff Area=7.050 ac 7.09% Impervious Runoff Depth>0.41"
Flow Length=420' Slope=0.0700 '/' Tc=9.3 min CN=70 Runoff=3.73 cfs 0.240 af

SubcatchmentN3: Subarea Runoff Area=26.920 ac 4.16% Impervious Runoff Depth>0.41"
Flow Length=1,810' Slope=0.0400 '/' Tc=27.6 min CN=70 Runoff=8.02 cfs 0.913 af

SubcatchmentN4: Subarea Runoff Area=20.910 ac 3.87% Impervious Runoff Depth>0.29"
Flow Length=290' Slope=0.0600 '/' Tc=9.0 min CN=66 Runoff=6.34 cfs 0.501 af

SubcatchmentS1: Subarea Runoff Area=15.500 ac 0.77% Impervious Runoff Depth>0.34"
Flow Length=1,075' Slope=0.0400 '/' Tc=17.9 min CN=68 Runoff=4.51 cfs 0.445 af

SubcatchmentW1: Subarea Runoff Area=9.750 ac 0.41% Impervious Runoff Depth>0.38"
Flow Length=810' Slope=0.0500 '/' Tc=14.1 min CN=69 Runoff=3.69 cfs 0.305 af

Pond 1D: Depression Peak Elev=975.04' Storage=0.264 af Inflow=4.41 cfs 0.467 af
Discarded=0.19 cfs 0.166 af Primary=0.30 cfs 0.065 af Outflow=0.49 cfs 0.232 af

Pond 2D: Depression Peak Elev=970.45' Storage=0.078 af Inflow=3.73 cfs 0.305 af
Discarded=0.12 cfs 0.088 af Primary=0.63 cfs 0.211 af Outflow=0.75 cfs 0.299 af

Pond 3D: Depression Peak Elev=952.66' Storage=0.028 af Inflow=8.58 cfs 1.124 af
Discarded=0.04 cfs 0.002 af Primary=7.55 cfs 1.122 af Outflow=7.58 cfs 1.124 af

Pond 4K: Kettle Peak Elev=946.85' Storage=1.155 af Inflow=10.24 cfs 1.623 af
Outflow=0.59 cfs 0.535 af

Pond 5D: Depression Peak Elev=953.16' Storage=0.196 af Inflow=3.69 cfs 0.305 af
Discarded=0.15 cfs 0.134 af Primary=0.00 cfs 0.000 af Outflow=0.15 cfs 0.134 af

Existing_2026-002

Prepared by Sound Stormwater Design

HydroCAD® 10.20-4c s/n 11025 © 2024 HydroCAD Software Solutions LLC

MSE 24-hr 3 1 yr Rainfall=2.40"

Printed 5/12/2026

Page 5

Pond 6D: Depression

Peak Elev=961.95' Storage=0.094 af Inflow=2.04 cfs 0.166 af
Discarded=0.11 cfs 0.100 af Primary=0.00 cfs 0.000 af Outflow=0.11 cfs 0.100 af

Pond 7D: Depression

Peak Elev=955.49' Storage=0.001 af Inflow=1.97 cfs 0.178 af
Discarded=0.00 cfs 0.001 af Primary=1.95 cfs 0.178 af Outflow=1.95 cfs 0.178 af

Link 1L: Discharge to County Road I

Inflow=2.66 cfs 0.307 af
Primary=2.66 cfs 0.307 af

Link 2L: Discharge South

Inflow=4.51 cfs 0.445 af
Primary=4.51 cfs 0.445 af

Total Runoff Area = 120.870 ac Runoff Volume = 3.344 af Average Runoff Depth = 0.33"
96.40% Pervious = 116.520 ac 3.60% Impervious = 4.350 ac

Time span=0.00-24.00 hrs, dt=0.01 hrs, 2401 points
Runoff by SCS TR-20 method, UH=SCS, Weighted-CN
Reach routing by Dyn-Stor-Ind method - Pond routing by Dyn-Stor-Ind method

SubcatchmentE1: Subarea Runoff Area=6.320 ac 4.75% Impervious Runoff Depth>0.44"
Flow Length=510' Slope=0.0700 '/' Tc=11.0 min CN=67 Runoff=3.29 cfs 0.233 af

SubcatchmentE2: Subarea Runoff Area=9.090 ac 4.40% Impervious Runoff Depth>0.34"
Flow Length=280' Slope=0.0800 '/' Tc=8.0 min CN=64 Runoff=3.67 cfs 0.261 af

SubcatchmentE3: Subarea Runoff Area=5.010 ac 7.58% Impervious Runoff Depth>0.34"
Flow Length=645' Slope=0.0400 '/' Tc=14.6 min CN=64 Runoff=1.50 cfs 0.144 af

SubcatchmentE4: Subarea Runoff Area=1.600 ac 5.00% Impervious Runoff Depth>0.29"
Flow Length=115' Slope=0.0300 '/' Tc=13.3 min CN=62 Runoff=0.36 cfs 0.038 af

SubcatchmentE5: Subarea Runoff Area=0.940 ac 0.00% Impervious Runoff Depth>0.14"
Flow Length=360' Slope=0.1000 '/' Tc=9.1 min CN=56 Runoff=0.06 cfs 0.011 af

SubcatchmentN1: Subarea Runoff Area=17.780 ac 3.37% Impervious Runoff Depth>0.44"
Flow Length=1,065' Tc=18.6 min CN=67 Runoff=7.01 cfs 0.655 af

SubcatchmentN2: Subarea Runoff Area=7.050 ac 7.09% Impervious Runoff Depth>0.55"
Flow Length=420' Slope=0.0700 '/' Tc=9.3 min CN=70 Runoff=5.49 cfs 0.325 af

SubcatchmentN3: Subarea Runoff Area=26.920 ac 4.16% Impervious Runoff Depth>0.55"
Flow Length=1,810' Slope=0.0400 '/' Tc=27.6 min CN=70 Runoff=11.71 cfs 1.239 af

SubcatchmentN4: Subarea Runoff Area=20.910 ac 3.87% Impervious Runoff Depth>0.41"
Flow Length=290' Slope=0.0600 '/' Tc=9.0 min CN=66 Runoff=10.65 cfs 0.711 af

SubcatchmentS1: Subarea Runoff Area=15.500 ac 0.77% Impervious Runoff Depth>0.48"
Flow Length=1,075' Slope=0.0400 '/' Tc=17.9 min CN=68 Runoff=6.99 cfs 0.617 af

SubcatchmentW1: Subarea Runoff Area=9.750 ac 0.41% Impervious Runoff Depth>0.51"
Flow Length=810' Slope=0.0500 '/' Tc=14.1 min CN=69 Runoff=5.56 cfs 0.418 af

Pond 1D: Depression Peak Elev=975.11' Storage=0.290 af Inflow=7.01 cfs 0.655 af
Discarded=0.22 cfs 0.177 af Primary=1.32 cfs 0.235 af Outflow=1.54 cfs 0.413 af

Pond 2D: Depression Peak Elev=970.69' Storage=0.138 af Inflow=5.49 cfs 0.561 af
Discarded=0.16 cfs 0.103 af Primary=1.37 cfs 0.447 af Outflow=1.52 cfs 0.550 af

Pond 3D: Depression Peak Elev=952.81' Storage=0.041 af Inflow=12.64 cfs 1.686 af
Discarded=0.05 cfs 0.003 af Primary=12.56 cfs 1.683 af Outflow=12.61 cfs 1.686 af

Pond 4K: Kettle Peak Elev=947.42' Storage=1.809 af Inflow=16.86 cfs 2.395 af
Outflow=0.72 cfs 0.655 af

Pond 5D: Depression Peak Elev=953.42' Storage=0.276 af Inflow=5.56 cfs 0.418 af
Discarded=0.19 cfs 0.179 af Primary=0.00 cfs 0.000 af Outflow=0.19 cfs 0.179 af

Existing_2026-002

Prepared by Sound Stormwater Design

HydroCAD® 10.20-4c s/n 11025 © 2024 HydroCAD Software Solutions LLC

MSE 24-hr 3 2 yr Rainfall=2.70"

Printed 5/12/2026

Page 34

Pond 6D: Depression

Peak Elev=962.14' Storage=0.140 af Inflow=3.29 cfs 0.233 af
Discarded=0.14 cfs 0.127 af Primary=0.00 cfs 0.000 af Outflow=0.14 cfs 0.127 af

Pond 7D: Depression

Peak Elev=955.94' Storage=0.004 af Inflow=3.67 cfs 0.261 af
Discarded=0.01 cfs 0.001 af Primary=3.29 cfs 0.260 af Outflow=3.30 cfs 0.261 af

Link 1L: Discharge to County Road I

Inflow=5.08 cfs 0.453 af
Primary=5.08 cfs 0.453 af

Link 2L: Discharge South

Inflow=6.99 cfs 0.617 af
Primary=6.99 cfs 0.617 af

Total Runoff Area = 120.870 ac Runoff Volume = 4.652 af Average Runoff Depth = 0.46"
96.40% Pervious = 116.520 ac 3.60% Impervious = 4.350 ac

Time span=0.00-24.00 hrs, dt=0.01 hrs, 2401 points
Runoff by SCS TR-20 method, UH=SCS, Weighted-CN
Reach routing by Dyn-Stor-Ind method - Pond routing by Dyn-Stor-Ind method

SubcatchmentE1: Subarea Runoff Area=6.320 ac 4.75% Impervious Runoff Depth>1.03"
Flow Length=510' Slope=0.0700 '/' Tc=11.0 min CN=67 Runoff=9.17 cfs 0.542 af

SubcatchmentE2: Subarea Runoff Area=9.090 ac 4.40% Impervious Runoff Depth>0.87"
Flow Length=280' Slope=0.0800 '/' Tc=8.0 min CN=64 Runoff=12.26 cfs 0.657 af

SubcatchmentE3: Subarea Runoff Area=5.010 ac 7.58% Impervious Runoff Depth>0.87"
Flow Length=645' Slope=0.0400 '/' Tc=14.6 min CN=64 Runoff=5.06 cfs 0.362 af

SubcatchmentE4: Subarea Runoff Area=1.600 ac 5.00% Impervious Runoff Depth>0.77"
Flow Length=115' Slope=0.0300 '/' Tc=13.3 min CN=62 Runoff=1.43 cfs 0.102 af

SubcatchmentE5: Subarea Runoff Area=0.940 ac 0.00% Impervious Runoff Depth>0.50"
Flow Length=360' Slope=0.1000 '/' Tc=9.1 min CN=56 Runoff=0.52 cfs 0.039 af

SubcatchmentN1: Subarea Runoff Area=17.780 ac 3.37% Impervious Runoff Depth>1.03"
Flow Length=1,065' Tc=18.6 min CN=67 Runoff=19.61 cfs 1.523 af

SubcatchmentN2: Subarea Runoff Area=7.050 ac 7.09% Impervious Runoff Depth>1.20"
Flow Length=420' Slope=0.0700 '/' Tc=9.3 min CN=70 Runoff=13.21 cfs 0.707 af

SubcatchmentN3: Subarea Runoff Area=26.920 ac 4.16% Impervious Runoff Depth>1.20"
Flow Length=1,810' Slope=0.0400 '/' Tc=27.6 min CN=70 Runoff=28.83 cfs 2.695 af

SubcatchmentN4: Subarea Runoff Area=20.910 ac 3.87% Impervious Runoff Depth>0.97"
Flow Length=290' Slope=0.0600 '/' Tc=9.0 min CN=66 Runoff=31.20 cfs 1.696 af

SubcatchmentS1: Subarea Runoff Area=15.500 ac 0.77% Impervious Runoff Depth>1.08"
Flow Length=1,075' Slope=0.0400 '/' Tc=17.9 min CN=68 Runoff=18.58 cfs 1.401 af

SubcatchmentW1: Subarea Runoff Area=9.750 ac 0.41% Impervious Runoff Depth>1.14"
Flow Length=810' Slope=0.0500 '/' Tc=14.1 min CN=69 Runoff=14.17 cfs 0.929 af

Pond 1D: Depression Peak Elev=975.40' Storage=0.450 af Inflow=19.61 cfs 1.523 af
Discarded=0.37 cfs 0.202 af Primary=9.77 cfs 1.068 af Outflow=10.14 cfs 1.271 af

Pond 2D: Depression Peak Elev=971.78' Storage=0.619 af Inflow=13.21 cfs 1.775 af
Discarded=0.31 cfs 0.162 af Primary=4.62 cfs 1.588 af Outflow=4.93 cfs 1.750 af

Pond 3D: Depression Peak Elev=953.02' Storage=0.063 af Inflow=31.90 cfs 4.283 af
Discarded=0.06 cfs 0.010 af Primary=31.75 cfs 4.273 af Outflow=31.82 cfs 4.283 af

Pond 4K: Kettle Peak Elev=949.45' Storage=5.054 af Inflow=42.94 cfs 6.072 af
Outflow=1.20 cfs 1.092 af

Pond 5D: Depression Peak Elev=954.07' Storage=0.596 af Inflow=14.17 cfs 0.929 af
Discarded=0.35 cfs 0.324 af Primary=0.42 cfs 0.103 af Outflow=0.77 cfs 0.427 af

Existing_2026-002

Prepared by Sound Stormwater Design

HydroCAD® 10.20-4c s/n 11025 © 2024 HydroCAD Software Solutions LLC

MSE 24-hr 3 10 yr Rainfall=3.81"

Printed 5/12/2026

Page 63

Pond 6D: Depression

Peak Elev=962.83' Storage=0.374 af Inflow=9.17 cfs 0.542 af
Discarded=0.23 cfs 0.218 af Primary=0.00 cfs 0.000 af Outflow=0.23 cfs 0.218 af

Pond 7D: Depression

Peak Elev=957.30' Storage=0.069 af Inflow=12.26 cfs 0.657 af
Discarded=0.09 cfs 0.003 af Primary=6.63 cfs 0.653 af Outflow=6.72 cfs 0.657 af

Link 1L: Discharge to County Road I

Inflow=13.53 cfs 1.156 af
Primary=13.53 cfs 1.156 af

Link 2L: Discharge South

Inflow=18.58 cfs 1.401 af
Primary=18.58 cfs 1.401 af

Total Runoff Area = 120.870 ac Runoff Volume = 10.652 af Average Runoff Depth = 1.06"
96.40% Pervious = 116.520 ac 3.60% Impervious = 4.350 ac

Time span=0.00-24.00 hrs, dt=0.01 hrs, 2401 points
Runoff by SCS TR-20 method, UH=SCS, Weighted-CN
Reach routing by Dyn-Stor-Ind method - Pond routing by Dyn-Stor-Ind method

SubcatchmentE1: Subarea Runoff Area=6.320 ac 4.75% Impervious Runoff Depth>2.66"
Flow Length=510' Slope=0.0700 '/' Tc=11.0 min CN=67 Runoff=25.27 cfs 1.403 af

SubcatchmentE2: Subarea Runoff Area=9.090 ac 4.40% Impervious Runoff Depth>2.39"
Flow Length=280' Slope=0.0800 '/' Tc=8.0 min CN=64 Runoff=36.77 cfs 1.811 af

SubcatchmentE3: Subarea Runoff Area=5.010 ac 7.58% Impervious Runoff Depth>2.39"
Flow Length=645' Slope=0.0400 '/' Tc=14.6 min CN=64 Runoff=15.53 cfs 0.998 af

SubcatchmentE4: Subarea Runoff Area=1.600 ac 5.00% Impervious Runoff Depth>2.21"
Flow Length=115' Slope=0.0300 '/' Tc=13.3 min CN=62 Runoff=4.75 cfs 0.295 af

SubcatchmentE5: Subarea Runoff Area=0.940 ac 0.00% Impervious Runoff Depth>1.70"
Flow Length=360' Slope=0.1000 '/' Tc=9.1 min CN=56 Runoff=2.46 cfs 0.133 af

SubcatchmentN1: Subarea Runoff Area=17.780 ac 3.37% Impervious Runoff Depth>2.66"
Flow Length=1,065' Tc=18.6 min CN=67 Runoff=54.65 cfs 3.945 af

SubcatchmentN2: Subarea Runoff Area=7.050 ac 7.09% Impervious Runoff Depth>2.95"
Flow Length=420' Slope=0.0700 '/' Tc=9.3 min CN=70 Runoff=33.31 cfs 1.731 af

SubcatchmentN3: Subarea Runoff Area=26.920 ac 4.16% Impervious Runoff Depth>2.94"
Flow Length=1,810' Slope=0.0400 '/' Tc=27.6 min CN=70 Runoff=74.17 cfs 6.600 af

SubcatchmentN4: Subarea Runoff Area=20.910 ac 3.87% Impervious Runoff Depth>2.57"
Flow Length=290' Slope=0.0600 '/' Tc=9.0 min CN=66 Runoff=87.97 cfs 4.483 af

SubcatchmentS1: Subarea Runoff Area=15.500 ac 0.77% Impervious Runoff Depth>2.76"
Flow Length=1,075' Slope=0.0400 '/' Tc=17.9 min CN=68 Runoff=50.45 cfs 3.560 af

SubcatchmentW1: Subarea Runoff Area=9.750 ac 0.41% Impervious Runoff Depth>2.85"
Flow Length=810' Slope=0.0500 '/' Tc=14.1 min CN=69 Runoff=37.09 cfs 2.316 af

Pond 1D: Depression Peak Elev=975.91' Storage=0.961 af Inflow=54.65 cfs 3.945 af
Discarded=0.73 cfs 0.252 af Primary=34.74 cfs 3.433 af Outflow=35.47 cfs 3.686 af

Pond 2D: Depression Peak Elev=973.64' Storage=2.014 af Inflow=45.87 cfs 5.165 af
Discarded=0.58 cfs 0.316 af Primary=27.07 cfs 4.793 af Outflow=27.65 cfs 5.109 af

Pond 3D: Depression Peak Elev=953.36' Storage=0.110 af Inflow=80.66 cfs 11.393 af
Discarded=0.09 cfs 0.059 af Primary=80.42 cfs 11.271 af Outflow=80.50 cfs 11.331 af

Pond 4K: Kettle Peak Elev=953.05' Storage=14.995 af Inflow=125.67 cfs 17.162 af
Outflow=2.62 cfs 2.303 af

Pond 5D: Depression Peak Elev=954.60' Storage=0.983 af Inflow=37.09 cfs 2.316 af
Discarded=0.46 cfs 0.360 af Primary=12.44 cfs 1.408 af Outflow=12.91 cfs 1.768 af

Existing_2026-002

Prepared by Sound Stormwater Design

HydroCAD® 10.20-4c s/n 11025 © 2024 HydroCAD Software Solutions LLC

MSE 24-hr 3 100 yr Rainfall=6.18"

Printed 5/12/2026

Page 92

Pond 6D: Depression

Peak Elev=963.60' Storage=0.811 af Inflow=25.27 cfs 1.403 af
Discarded=0.41 cfs 0.384 af Primary=2.37 cfs 0.337 af Outflow=2.78 cfs 0.721 af

Pond 7D: Depression

Peak Elev=957.62' Storage=0.145 af Inflow=36.77 cfs 2.149 af
Discarded=0.18 cfs 0.012 af Primary=34.22 cfs 2.136 af Outflow=34.39 cfs 2.149 af

Link 1L: Discharge to County Road I

Inflow=55.38 cfs 3.562 af
Primary=55.38 cfs 3.562 af

Link 2L: Discharge South

Inflow=50.45 cfs 3.560 af
Primary=50.45 cfs 3.560 af

Total Runoff Area = 120.870 ac Runoff Volume = 27.277 af Average Runoff Depth = 2.71"
96.40% Pervious = 116.520 ac 3.60% Impervious = 4.350 ac

Summary for Subcatchment E1: Subarea

Runoff = 25.27 cfs @ 12.19 hrs, Volume= 1.403 af, Depth> 2.66"
 Routed to Pond 6D : Depression

Runoff by SCS TR-20 method, UH=SCS, Weighted-CN, Time Span= 0.00-24.00 hrs, dt= 0.01 hrs
 MSE 24-hr 3 100 yr Rainfall=6.18"

Area (ac)	CN	Description
* 3.620	69	cropland
* 2.160	61	grass
* 0.240	55	woodland
* 0.300	98	impervious
6.320	67	Weighted Average
6.020		95.25% Pervious Area
0.300		4.75% Impervious Area

Tc (min)	Length (feet)	Slope (ft/ft)	Velocity (ft/sec)	Capacity (cfs)	Description
9.4	100	0.0700	0.18		Sheet Flow, Grass: Dense n= 0.240 P2= 2.70"
1.6	410	0.0700	4.26		Shallow Concentrated Flow, Unpaved Kv= 16.1 fps
11.0	510	Total			

Subcatchment E1: Subarea

Hydrograph

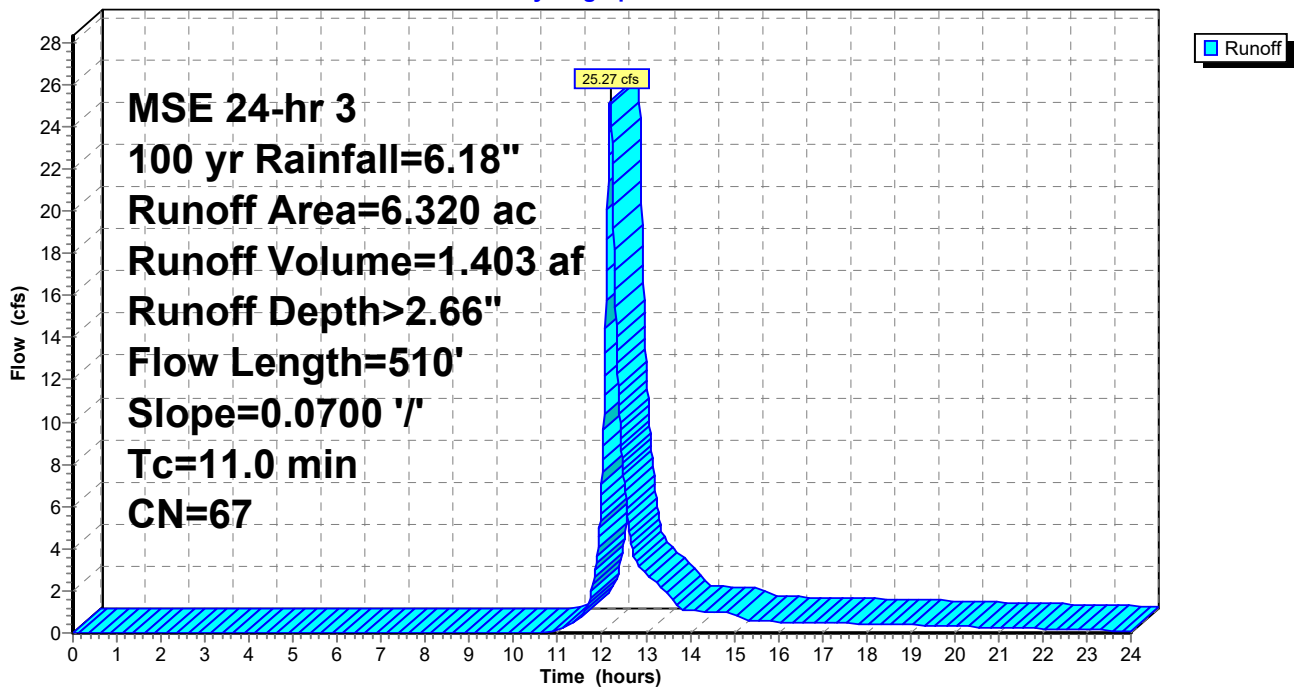

Summary for Subcatchment E2: Subarea

Runoff = 36.77 cfs @ 12.16 hrs, Volume= 1.811 af, Depth> 2.39"
 Routed to Pond 7D : Depression

Runoff by SCS TR-20 method, UH=SCS, Weighted-CN, Time Span= 0.00-24.00 hrs, dt= 0.01 hrs
 MSE 24-hr 3 100 yr Rainfall=6.18"

Area (ac)	CN	Description
* 3.170	69	cropland
* 3.410	61	grass
* 2.110	55	woodland
* 0.400	98	impervious
9.090	64	Weighted Average
8.690		95.60% Pervious Area
0.400		4.40% Impervious Area

Tc (min)	Length (feet)	Slope (ft/ft)	Velocity (ft/sec)	Capacity (cfs)	Description
6.8	100	0.0800	0.25		Sheet Flow, Cultivated: Residue>20% n= 0.170 P2= 2.70"
1.2	180	0.0800	2.55		Shallow Concentrated Flow, Cultivated Straight Rows Kv= 9.0 fps
8.0	280	Total			

Subcatchment E2: Subarea

Hydrograph

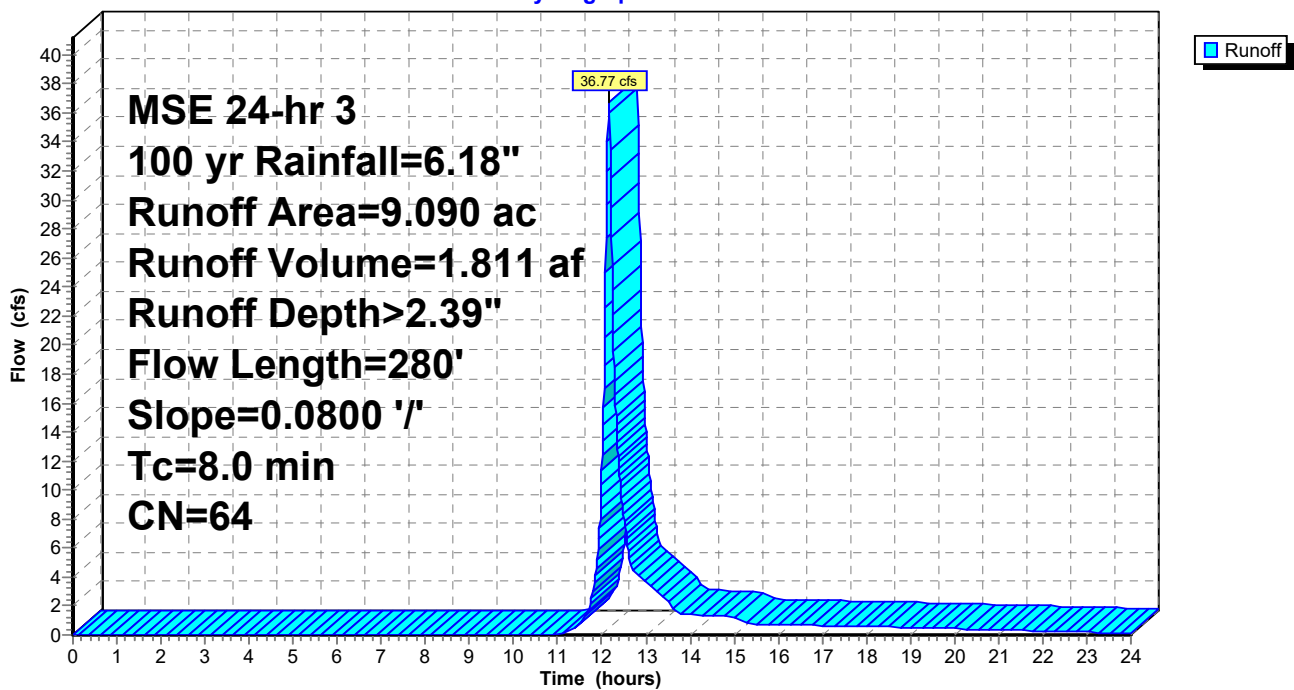

Summary for Subcatchment E3: Subarea

Runoff = 15.53 cfs @ 12.24 hrs, Volume= 0.998 af, Depth> 2.39"
 Routed to Link 1L : Discharge to County Road I

Runoff by SCS TR-20 method, UH=SCS, Weighted-CN, Time Span= 0.00-24.00 hrs, dt= 0.01 hrs
 MSE 24-hr 3 100 yr Rainfall=6.18"

Area (ac)	CN	Description
* 0.010	69	cropland
* 4.620	61	grass
* 0.380	98	impervious
5.010	64	Weighted Average
4.630		92.42% Pervious Area
0.380		7.58% Impervious Area

Tc (min)	Length (feet)	Slope (ft/ft)	Velocity (ft/sec)	Capacity (cfs)	Description
11.8	100	0.0400	0.14		Sheet Flow, Grass: Dense n= 0.240 P2= 2.70"
2.8	545	0.0400	3.22		Shallow Concentrated Flow, Unpaved Kv= 16.1 fps
14.6	645	Total			

Subcatchment E3: Subarea

Hydrograph

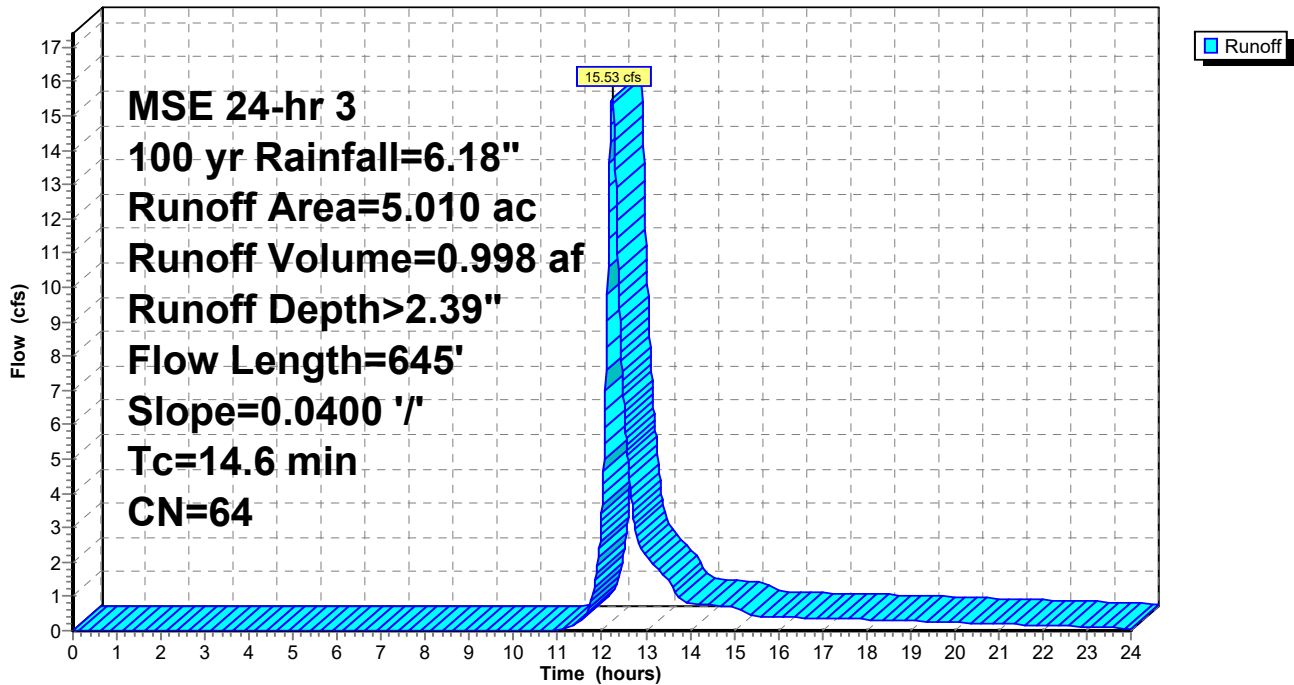

Summary for Subcatchment E4: Subarea

Runoff = 4.75 cfs @ 12.22 hrs, Volume= 0.295 af, Depth> 2.21"
 Routed to Link 1L : Discharge to County Road I

Runoff by SCS TR-20 method, UH=SCS, Weighted-CN, Time Span= 0.00-24.00 hrs, dt= 0.01 hrs
 MSE 24-hr 3 100 yr Rainfall=6.18"

Area (ac)	CN	Description
* 1.400	61	grass
* 0.120	55	woodland
* 0.080	98	impervious
1.600	62	Weighted Average
1.520		95.00% Pervious Area
0.080		5.00% Impervious Area

Tc (min)	Length (feet)	Slope (ft/ft)	Velocity (ft/sec)	Capacity (cfs)	Description
13.2	100	0.0300	0.13		Sheet Flow, Grass: Dense n= 0.240 P2= 2.70"
0.1	15	0.0300	2.79		Shallow Concentrated Flow, Unpaved Kv= 16.1 fps
13.3	115	Total			

Subcatchment E4: Subarea

Hydrograph

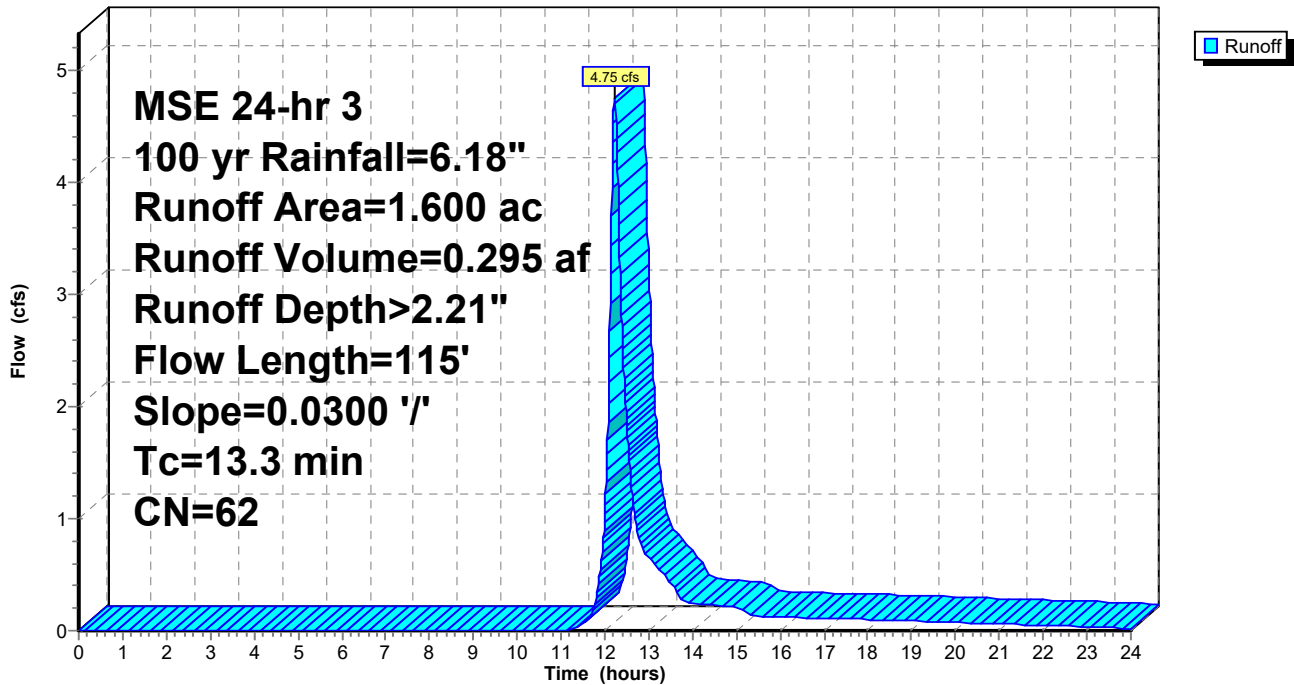

Summary for Subcatchment E5: Subarea

Runoff = 2.46 cfs @ 12.18 hrs, Volume= 0.133 af, Depth> 1.70"
 Routed to Link 1L : Discharge to County Road I

Runoff by SCS TR-20 method, UH=SCS, Weighted-CN, Time Span= 0.00-24.00 hrs, dt= 0.01 hrs
 MSE 24-hr 3 100 yr Rainfall=6.18"

Area (ac)	CN	Description
* 0.150	61	grass
* 0.790	55	woodland
0.940	56	Weighted Average
0.940		100.00% Pervious Area

Tc (min)	Length (feet)	Slope (ft/ft)	Velocity (ft/sec)	Capacity (cfs)	Description
8.2	100	0.1000	0.20		Sheet Flow, Grass: Dense n= 0.240 P2= 2.70"
0.9	260	0.1000	5.09		Shallow Concentrated Flow, Unpaved Kv= 16.1 fps
9.1	360	Total			

Subcatchment E5: Subarea

Hydrograph

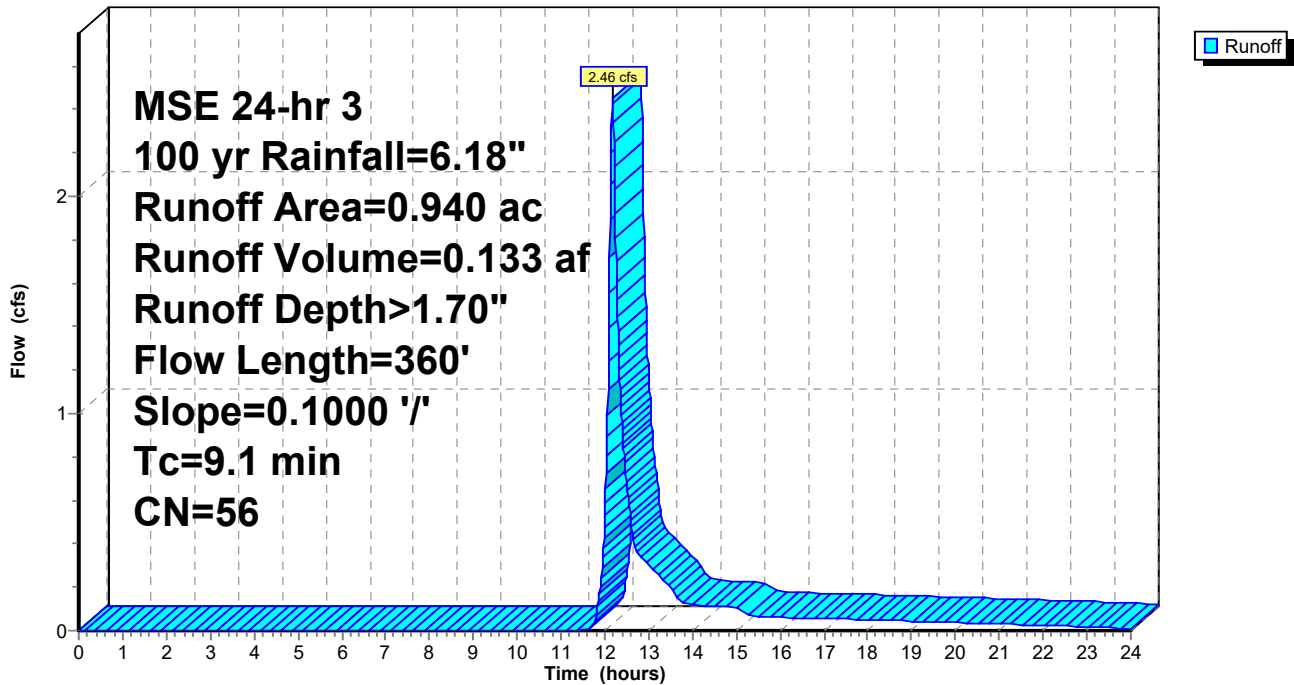

Summary for Subcatchment N1: Subarea

Runoff = 54.65 cfs @ 12.29 hrs, Volume= 3.945 af, Depth> 2.66"
 Routed to Pond 1D : Depression

Runoff by SCS TR-20 method, UH=SCS, Weighted-CN, Time Span= 0.00-24.00 hrs, dt= 0.01 hrs
 MSE 24-hr 3 100 yr Rainfall=6.18"

Area (ac)	CN	Description
* 10.590	69	cropland
* 6.590	61	grass
* 0.600	98	impervious
17.780	67	Weighted Average
17.180		96.63% Pervious Area
0.600		3.37% Impervious Area

Tc (min)	Length (feet)	Slope (ft/ft)	Velocity (ft/sec)	Capacity (cfs)	Description
7.1	100	0.0700	0.23		Sheet Flow, Cultivated: Residue>20% n= 0.170 P2= 2.70"
3.9	555	0.0700	2.38		Shallow Concentrated Flow, Cultivated Straight Rows Kv= 9.0 fps
7.6	410	0.0100	0.90		Shallow Concentrated Flow, Cultivated Straight Rows Kv= 9.0 fps
18.6	1,065	Total			

Subcatchment N1: Subarea

Hydrograph

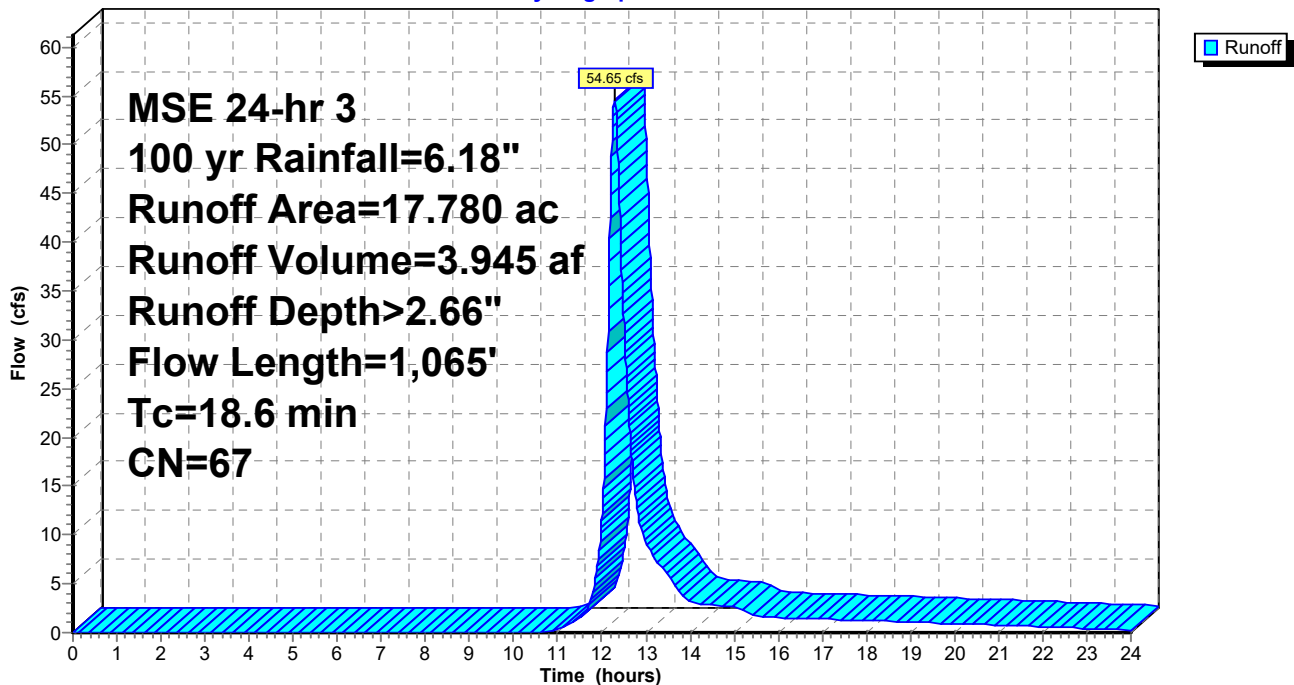

Summary for Subcatchment N2: Subarea

Runoff = 33.31 cfs @ 12.17 hrs, Volume= 1.731 af, Depth> 2.95"
 Routed to Pond 2D : Depression

Runoff by SCS TR-20 method, UH=SCS, Weighted-CN, Time Span= 0.00-24.00 hrs, dt= 0.01 hrs
 MSE 24-hr 3 100 yr Rainfall=6.18"

Area (ac)	CN	Description
* 5.220	69	cropland
* 1.330	61	grass
* 0.500	98	impervious
7.050	70	Weighted Average
6.550		92.91% Pervious Area
0.500		7.09% Impervious Area

Tc (min)	Length (feet)	Slope (ft/ft)	Velocity (ft/sec)	Capacity (cfs)	Description
7.1	100	0.0700	0.23		Sheet Flow, Cultivated: Residue>20% n= 0.170 P2= 2.70"
2.2	320	0.0700	2.38		Shallow Concentrated Flow, Cultivated Straight Rows Kv= 9.0 fps
9.3	420	Total			

Subcatchment N2: Subarea

Hydrograph

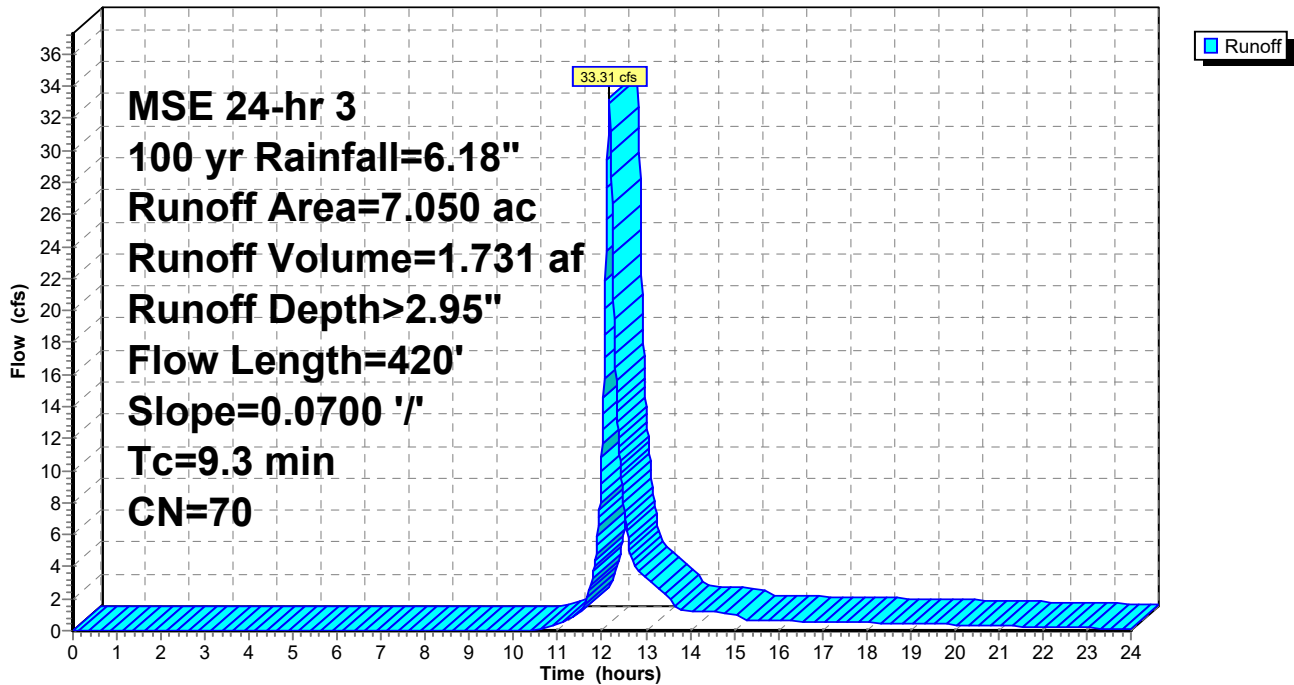

Summary for Subcatchment N3: Subarea

Runoff = 74.17 cfs @ 12.41 hrs, Volume= 6.600 af, Depth> 2.94"
 Routed to Pond 3D : Depression

Runoff by SCS TR-20 method, UH=SCS, Weighted-CN, Time Span= 0.00-24.00 hrs, dt= 0.01 hrs
 MSE 24-hr 3 100 yr Rainfall=6.18"

Area (ac)	CN	Description
* 24.440	69	cropland
* 1.360	61	grass
* 1.120	98	impervious
26.920	70	Weighted Average
25.800		95.84% Pervious Area
1.120		4.16% Impervious Area

Tc (min)	Length (feet)	Slope (ft/ft)	Velocity (ft/sec)	Capacity (cfs)	Description
11.8	100	0.0400	0.14		Sheet Flow, Grass: Dense n= 0.240 P2= 2.70"
15.8	1,710	0.0400	1.80		Shallow Concentrated Flow, Cultivated Straight Rows Kv= 9.0 fps
27.6	1,810	Total			

Subcatchment N3: Subarea

Hydrograph

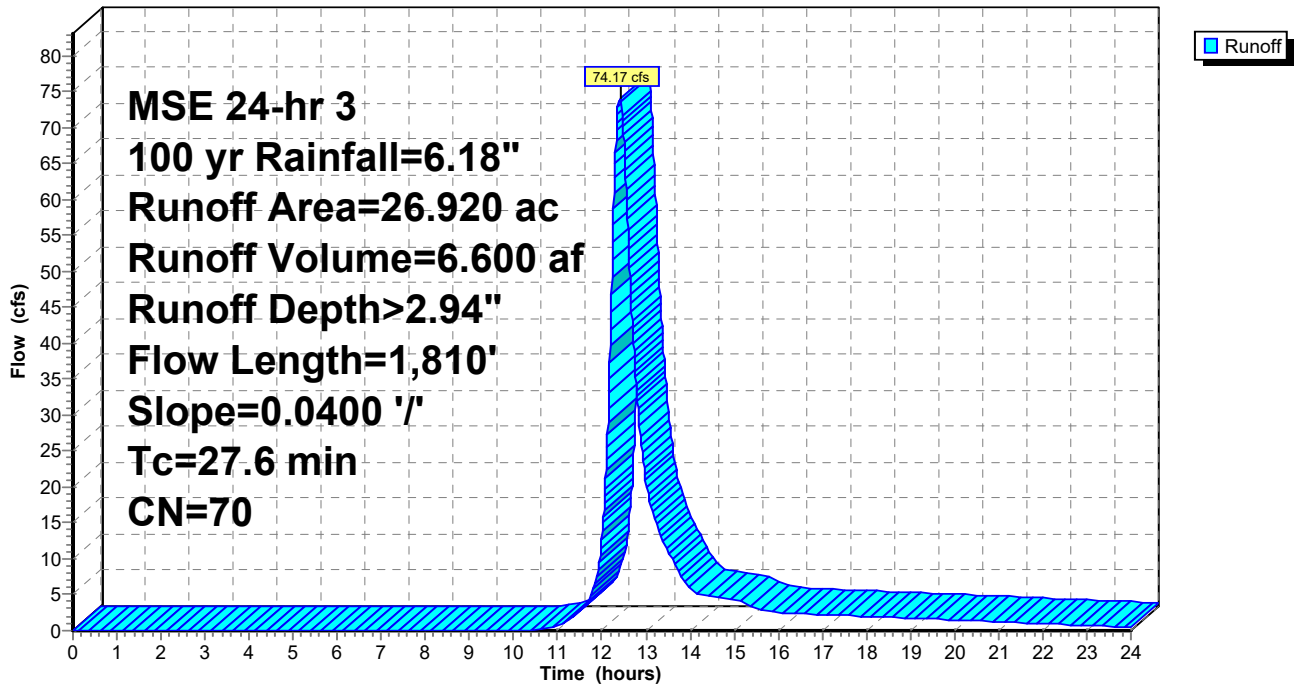

Summary for Subcatchment N4: Subarea

Runoff = 87.97 cfs @ 12.17 hrs, Volume= 4.483 af, Depth> 2.57"
 Routed to Pond 4K : Kettle

Runoff by SCS TR-20 method, UH=SCS, Weighted-CN, Time Span= 0.00-24.00 hrs, dt= 0.01 hrs
 MSE 24-hr 3 100 yr Rainfall=6.18"

Area (ac)	CN	Description
* 10.550	69	cropland
* 9.550	61	grass
* 0.810	98	impervious
20.910	66	Weighted Average
20.100		96.13% Pervious Area
0.810		3.87% Impervious Area

Tc (min)	Length (feet)	Slope (ft/ft)	Velocity (ft/sec)	Capacity (cfs)	Description
7.6	100	0.0600	0.22		Sheet Flow, Cultivated: Residue>20% n= 0.170 P2= 2.70"
1.4	190	0.0600	2.20		Shallow Concentrated Flow, Cultivated Straight Rows Kv= 9.0 fps
9.0	290	Total			

Subcatchment N4: Subarea

Hydrograph

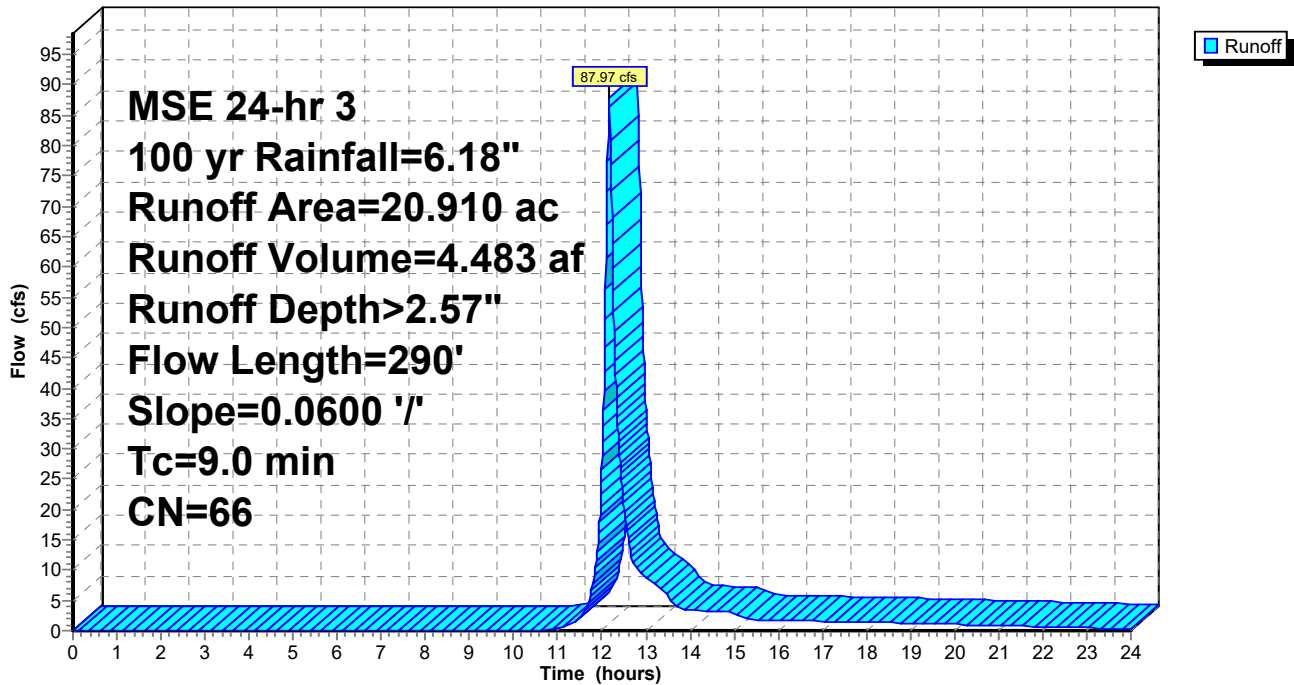

Summary for Subcatchment S1: Subarea

Runoff = 50.45 cfs @ 12.27 hrs, Volume= 3.560 af, Depth> 2.76"
 Routed to Link 2L : Discharge South

Runoff by SCS TR-20 method, UH=SCS, Weighted-CN, Time Span= 0.00-24.00 hrs, dt= 0.01 hrs
 MSE 24-hr 3 100 yr Rainfall=6.18"

Area (ac)	CN	Description
* 0.900	61	grass
* 13.940	69	cropland
* 0.540	55	woodland
* 0.120	98	impervious
15.500	68	Weighted Average
15.380		99.23% Pervious Area
0.120		0.77% Impervious Area

Tc (min)	Length (feet)	Slope (ft/ft)	Velocity (ft/sec)	Capacity (cfs)	Description
8.9	100	0.0400	0.19		Sheet Flow, Cultivated: Residue>20% n= 0.170 P2= 2.70"
9.0	975	0.0400	1.80		Shallow Concentrated Flow, Cultivated Straight Rows Kv= 9.0 fps
17.9	1,075	Total			

Subcatchment S1: Subarea

Hydrograph

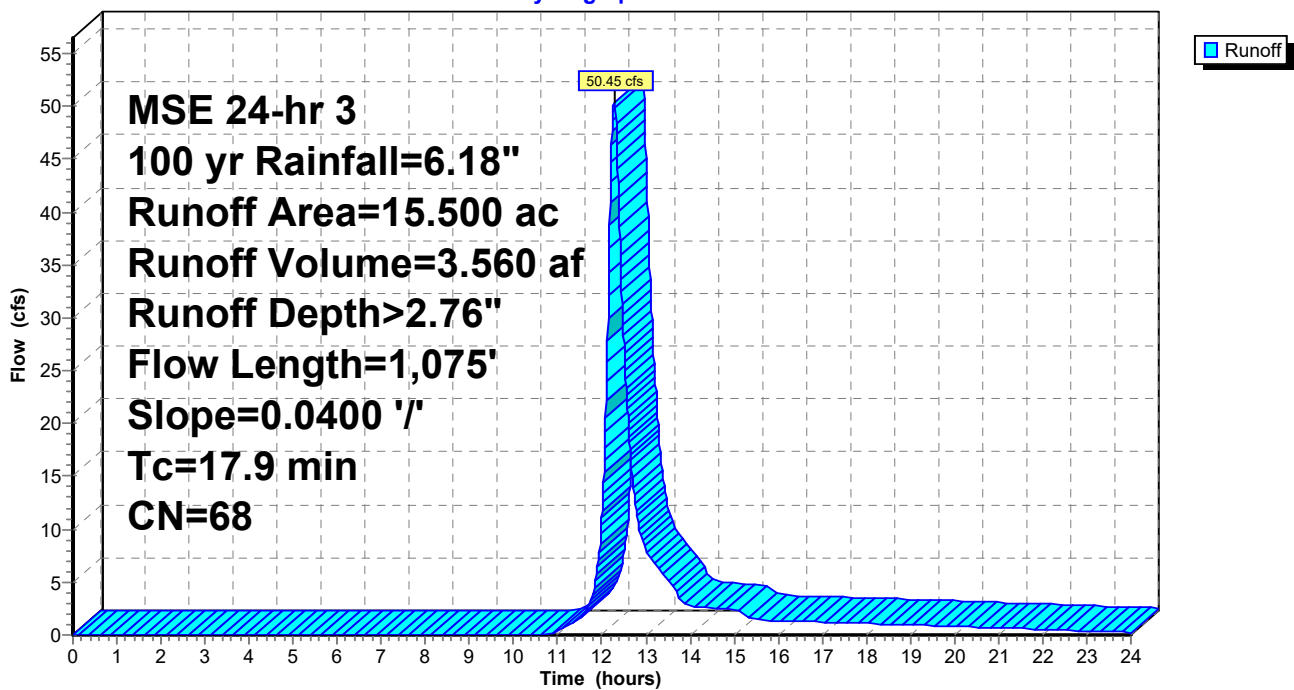

Summary for Subcatchment W1: Subarea

Runoff = 37.09 cfs @ 12.23 hrs, Volume= 2.316 af, Depth> 2.85"
 Routed to Pond 5D : Depression

Runoff by SCS TR-20 method, UH=SCS, Weighted-CN, Time Span= 0.00-24.00 hrs, dt= 0.01 hrs
 MSE 24-hr 3 100 yr Rainfall=6.18"

Area (ac)	CN	Description
* 0.700	61	grass
* 9.010	69	cropland
* 0.040	98	impervious
9.750	69	Weighted Average
9.710		99.59% Pervious Area
0.040		0.41% Impervious Area

Tc (min)	Length (feet)	Slope (ft/ft)	Velocity (ft/sec)	Capacity (cfs)	Description
8.2	100	0.0500	0.20		Sheet Flow, Cultivated: Residue>20% n= 0.170 P2= 2.70"
5.9	710	0.0500	2.01		Shallow Concentrated Flow, Cultivated Straight Rows Kv= 9.0 fps
14.1	810	Total			

Subcatchment W1: Subarea

Hydrograph

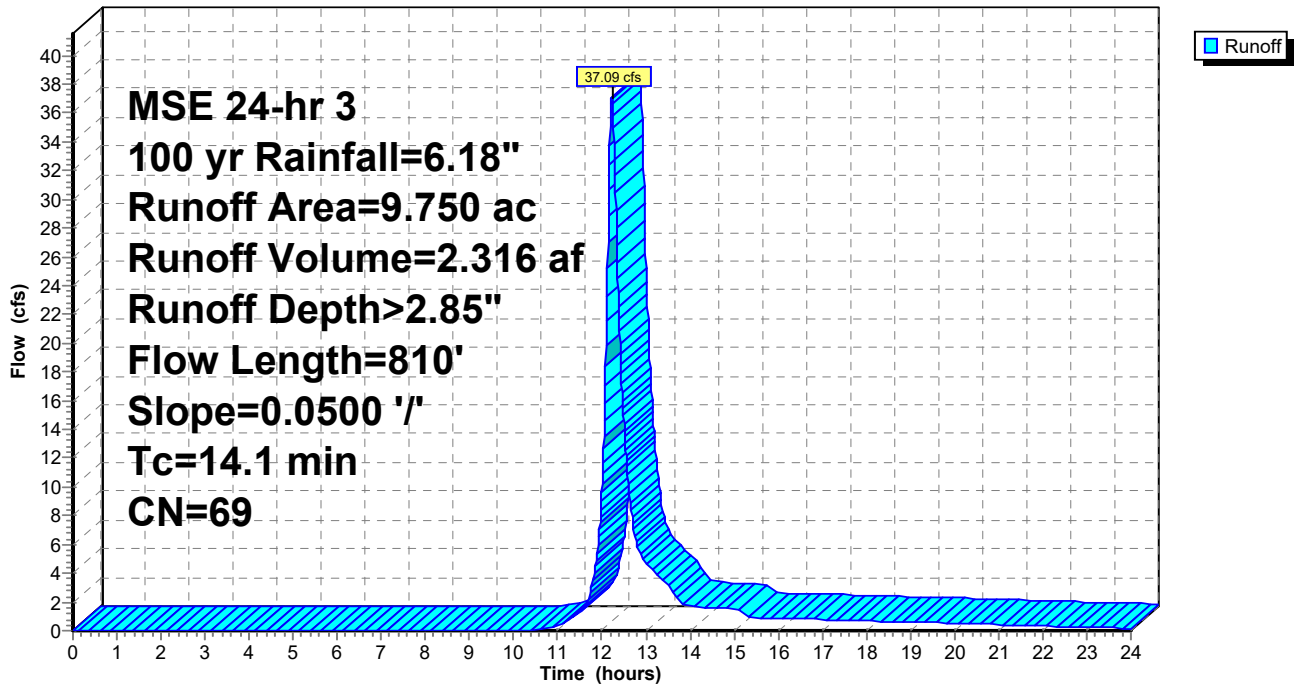

Summary for Pond 1D: Depression

Inflow Area = 17.780 ac, 3.37% Impervious, Inflow Depth > 2.66" for 100 yr event
 Inflow = 54.65 cfs @ 12.29 hrs, Volume= 3.945 af
 Outflow = 35.47 cfs @ 12.46 hrs, Volume= 3.686 af, Atten= 35%, Lag= 10.6 min
 Discarded = 0.73 cfs @ 12.46 hrs, Volume= 0.252 af
 Primary = 34.74 cfs @ 12.46 hrs, Volume= 3.433 af
 Routed to Pond 2D : Depression

Routing by Dyn-Stor-Ind method, Time Span= 0.00-24.00 hrs, dt= 0.01 hrs
 Peak Elev= 975.91' @ 12.46 hrs Surf.Area= 1.369 ac Storage= 0.961 af

Plug-Flow detention time= 53.2 min calculated for 3.686 af (93% of inflow)
 Center-of-Mass det. time= 22.0 min (847.9 - 825.8)

Volume	Invert	Avail.Storage	Storage Description
#1	973.00'	1.097 af	Custom Stage Data (Conic) Listed below (Recalc)
Elevation (feet)	Surf.Area (acres)	Inc.Store (acre-feet)	Cum.Store (acre-feet) Wet.Area (acres)
973.00	0.050	0.000	0.000 0.050
974.00	0.080	0.064	0.064 0.080
975.00	0.320	0.187	0.251 0.320
976.00	1.520	0.846	1.097 1.521

Device	Routing	Invert	Outlet Devices
#1	Discarded	973.00'	0.500 in/hr Exfiltration over Surface area Conductivity to Groundwater Elevation = 963.00' Phase-In= 0.01'
#2	Primary	975.00'	15.0' long x 10.0' breadth Broad-Crested Rectangular Weir Head (feet) 0.20 0.40 0.60 0.80 1.00 1.20 1.40 1.60 Coef. (English) 2.49 2.56 2.70 2.69 2.68 2.69 2.67 2.64

Discarded OutFlow Max=0.73 cfs @ 12.46 hrs HW=975.91' (Free Discharge)
 ↑1=Exfiltration (Controls 0.73 cfs)

Primary OutFlow Max=34.73 cfs @ 12.46 hrs HW=975.91' TW=972.95' (Dynamic Tailwater)
 ↑2=Broad-Crested Rectangular Weir(Weir Controls 34.73 cfs @ 2.56 fps)

Pond 1D: Depression

Hydrograph

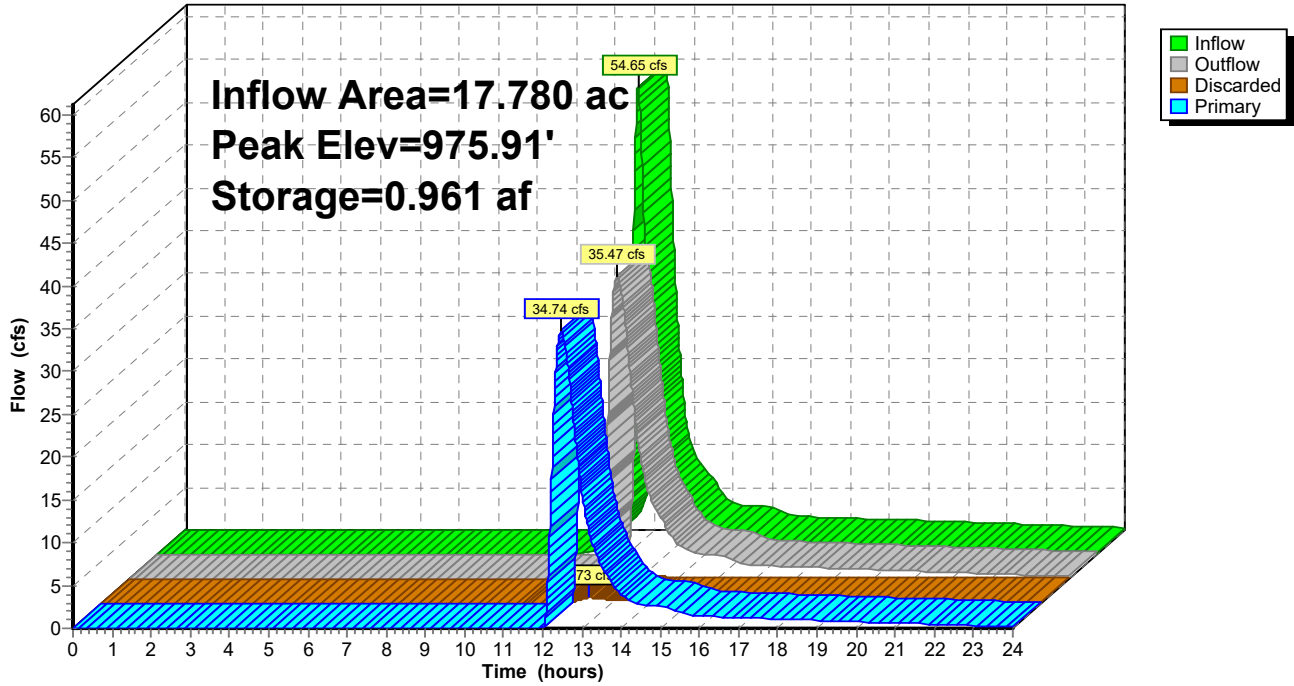

Summary for Pond 2D: Depression

Inflow Area = 24.830 ac, 4.43% Impervious, Inflow Depth > 2.50" for 100 yr event
 Inflow = 45.87 cfs @ 12.21 hrs, Volume= 5.165 af
 Outflow = 27.65 cfs @ 12.80 hrs, Volume= 5.109 af, Atten= 40%, Lag= 35.5 min
 Discarded = 0.58 cfs @ 12.80 hrs, Volume= 0.316 af
 Primary = 27.07 cfs @ 12.80 hrs, Volume= 4.793 af
 Routed to Pond 3D : Depression

Routing by Dyn-Stor-Ind method, Time Span= 0.00-24.00 hrs, dt= 0.01 hrs
 Peak Elev= 973.64' @ 12.80 hrs Surf.Area= 0.968 ac Storage= 2.014 af

Plug-Flow detention time= 106.1 min calculated for 5.109 af (99% of inflow)
 Center-of-Mass det. time= 100.1 min (928.0 - 827.9)

Volume	Invert	Avail.Storage	Storage Description
#1	970.00'	2.382 af	Custom Stage Data (Conic) Listed below (Recalc)
Elevation (feet)	Surf.Area (acres)	Inc.Store (acre-feet)	Cum.Store (acre-feet) Wet.Area (acres)
970.00	0.120	0.000	0.000 0.120
971.00	0.400	0.246	0.246 0.400
972.00	0.610	0.501	0.748 0.610
973.00	0.800	0.703	1.451 0.801
974.00	1.070	0.932	2.382 1.071

Device	Routing	Invert	Outlet Devices
#1	Discarded	970.00'	0.500 in/hr Exfiltration over Surface area Conductivity to Groundwater Elevation = 960.00' Phase-In= 0.01'
#2	Primary	970.00'	15.0" Round Culvert L= 40.0' CMP, end-section conforming to fill, Ke= 0.500 Inlet / Outlet Invert= 970.00' / 969.50' S= 0.0125 '/' Cc= 0.900 n= 0.024, Flow Area= 1.23 sf
#3	Primary	973.50'	150.0' long x 10.0' breadth Broad-Crested Rectangular Weir Head (feet) 0.20 0.40 0.60 0.80 1.00 1.20 1.40 1.60 Coef. (English) 2.49 2.56 2.70 2.69 2.68 2.69 2.67 2.64

Discarded OutFlow Max=0.58 cfs @ 12.80 hrs HW=973.64' (Free Discharge)
 ↖1=Exfiltration (Controls 0.58 cfs)

Primary OutFlow Max=27.06 cfs @ 12.80 hrs HW=973.64' TW=953.24' (Dynamic Tailwater)
 ↖2=Culvert (Barrel Controls 7.74 cfs @ 6.31 fps)
 ↖3=Broad-Crested Rectangular Weir(Weir Controls 19.32 cfs @ 0.93 fps)

Pond 2D: Depression

Hydrograph

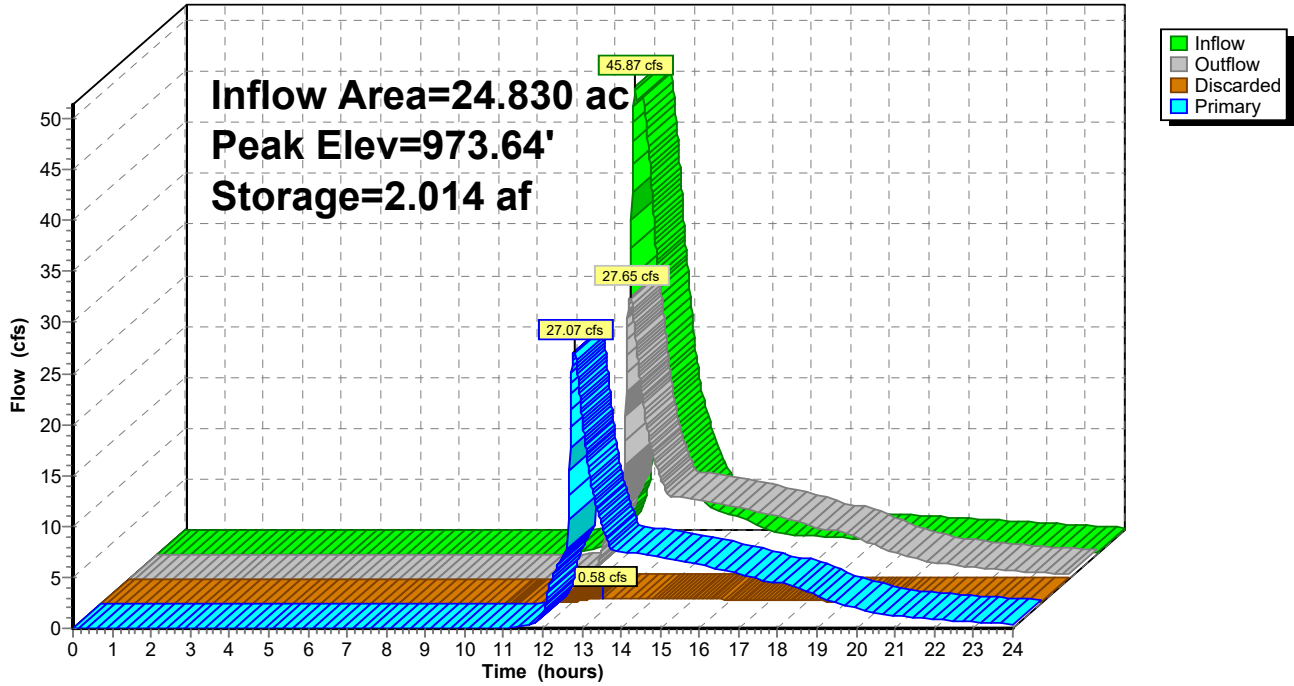

Summary for Pond 3D: Depression

Inflow Area = 51.750 ac, 4.29% Impervious, Inflow Depth > 2.64" for 100 yr event
 Inflow = 80.66 cfs @ 12.42 hrs, Volume= 11.393 af
 Outflow = 80.50 cfs @ 12.42 hrs, Volume= 11.331 af, Atten= 0%, Lag= 0.4 min
 Discarded = 0.09 cfs @ 12.42 hrs, Volume= 0.059 af
 Primary = 80.42 cfs @ 12.42 hrs, Volume= 11.271 af
 Routed to Pond 4K : Kettle

Routing by Dyn-Stor-Ind method, Time Span= 0.00-24.00 hrs, dt= 0.01 hrs
 Peak Elev= 953.36' @ 12.42 hrs Surf.Area= 0.161 ac Storage= 0.110 af

Plug-Flow detention time= 3.5 min calculated for 11.326 af (99% of inflow)
 Center-of-Mass det. time= 0.5 min (869.8 - 869.3)

Volume	Invert	Avail.Storage	Storage Description		
#1	950.40'	0.563 af	Custom Stage Data (Conic) Listed below (Recalc)		
Elevation (feet)	Surf.Area (acres)	Inc.Store (acre-feet)	Cum.Store (acre-feet)	Wet.Area (acres)	
950.40	0.000	0.000	0.000	0.000	
952.00	0.010	0.005	0.005	0.010	
953.00	0.120	0.055	0.060	0.120	
954.00	0.250	0.181	0.241	0.250	
955.00	0.400	0.322	0.563	0.401	

Device	Routing	Invert	Outlet Devices						
#1	Discarded	950.40'	0.500 in/hr Exfiltration over Surface area Conductivity to Groundwater Elevation = 940.00' Phase-In= 0.01'						
#2	Primary	950.40'	15.0" Round Culvert L= 30.0' CMP, end-section conforming to fill, Ke= 0.500 Inlet / Outlet Invert= 950.40' / 948.95' S= 0.0483 '/' Cc= 0.900 n= 0.024, Flow Area= 1.23 sf						
#3	Primary	952.70'	50.0' long x 10.0' breadth Broad-Crested Rectangular Weir Head (feet) 0.20 0.40 0.60 0.80 1.00 1.20 1.40 1.60 Coef. (English) 2.49 2.56 2.70 2.69 2.68 2.69 2.67 2.64						

Discarded OutFlow Max=0.09 cfs @ 12.42 hrs HW=953.36' (Free Discharge)
 ↖1=Exfiltration (Controls 0.09 cfs)

Primary OutFlow Max=80.40 cfs @ 12.42 hrs HW=953.36' TW=949.02' (Dynamic Tailwater)
 ↖2=Culvert (Barrel Controls 8.88 cfs @ 7.23 fps)
 ↖3=Broad-Crested Rectangular Weir(Weir Controls 71.52 cfs @ 2.18 fps)

Pond 3D: Depression

Hydrograph

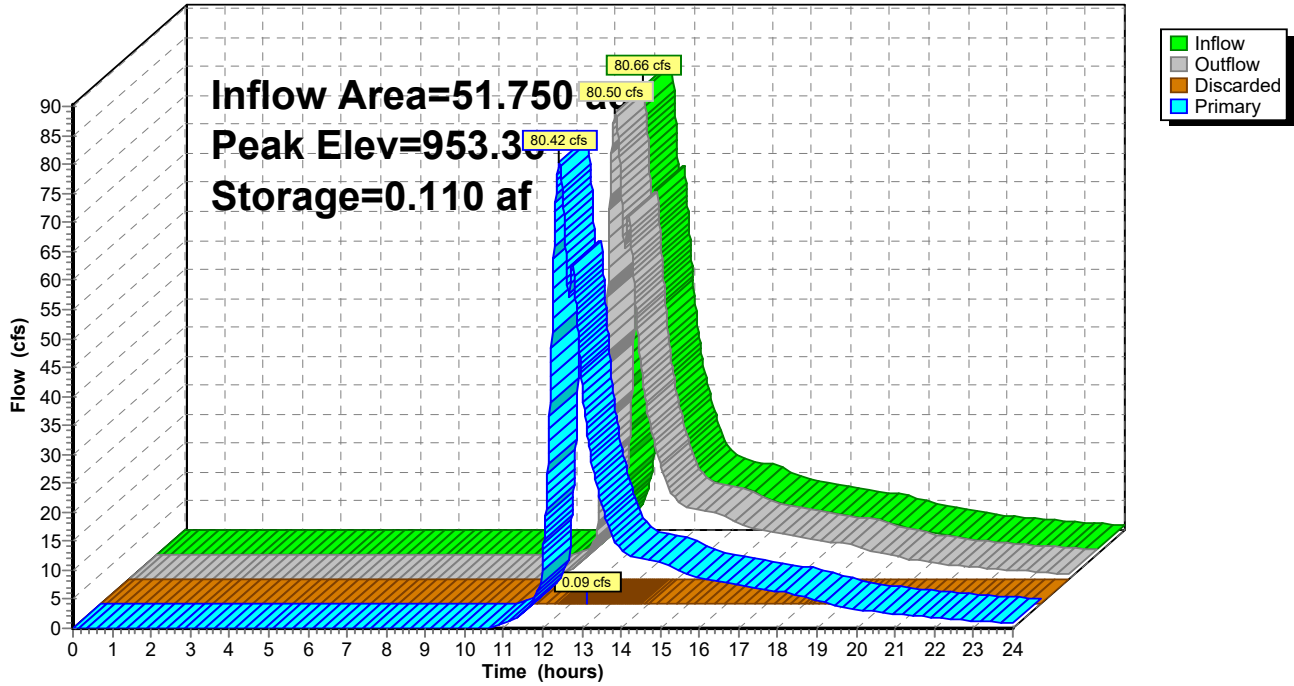

Summary for Pond 4K: Kettle

Inflow Area = 82.410 ac, 3.73% Impervious, Inflow Depth > 2.50" for 100 yr event
 Inflow = 125.67 cfs @ 12.18 hrs, Volume= 17.162 af
 Outflow = 2.62 cfs @ 21.90 hrs, Volume= 2.303 af, Atten= 98%, Lag= 583.0 min
 Discarded = 2.62 cfs @ 21.90 hrs, Volume= 2.303 af

Routing by Dyn-Stor-Ind method, Time Span= 0.00-24.00 hrs, dt= 0.01 hrs
 Peak Elev= 953.05' @ 21.90 hrs Surf.Area= 3.974 ac Storage= 14.995 af

Plug-Flow detention time= 388.6 min calculated for 2.302 af (13% of inflow)
 Center-of-Mass det. time= 256.1 min (1,109.2 - 853.1)

Volume	Invert	Avail.Storage	Storage Description
#1	944.80'	24.910 af	Custom Stage Data (Conic) Listed below (Recalc)

Elevation (feet)	Surf.Area (acres)	Inc.Store (acre-feet)	Cum.Store (acre-feet)	Wet.Area (acres)
944.80	0.000	0.000	0.000	0.000
945.00	0.140	0.009	0.009	0.140
946.00	0.720	0.392	0.402	0.720
947.00	1.120	0.913	1.314	1.120
948.00	1.460	1.286	2.601	1.461
949.00	1.790	1.622	4.223	1.792
950.00	2.130	1.958	6.180	2.133
951.00	2.520	2.322	8.503	2.523
952.00	3.080	2.795	11.298	3.084
953.00	3.900	3.482	14.780	3.905
954.00	5.360	4.611	19.391	5.365
955.00	5.680	5.519	24.910	5.688

Device	Routing	Invert	Outlet Devices
#1	Discarded	944.80'	0.500 in/hr Exfiltration over Surface area Conductivity to Groundwater Elevation = 935.00' Phase-In= 0.01'

Discarded OutFlow Max=2.62 cfs @ 21.90 hrs HW=953.05' (Free Discharge)
 ↑1=Exfiltration (Controls 2.62 cfs)

Pond 4K: Kettle

Hydrograph

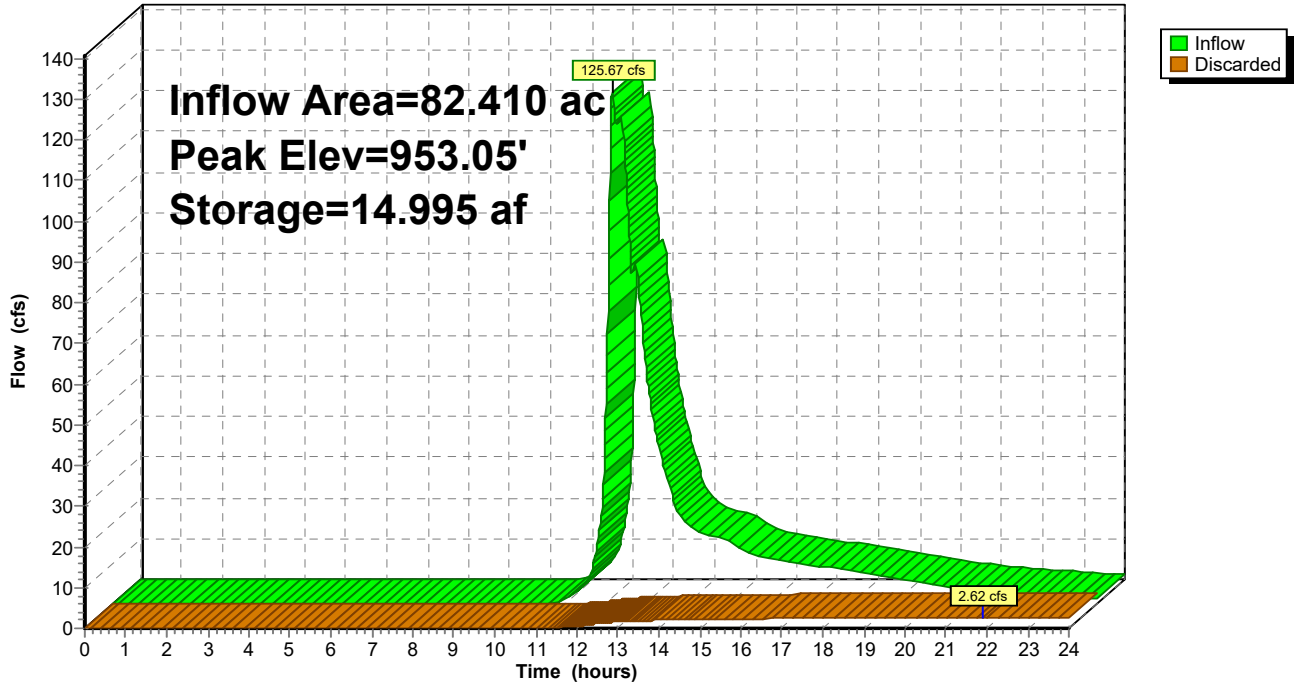

Summary for Pond 5D: Depression

Inflow Area = 9.750 ac, 0.41% Impervious, Inflow Depth > 2.85" for 100 yr event
 Inflow = 37.09 cfs @ 12.23 hrs, Volume= 2.316 af
 Outflow = 12.91 cfs @ 12.53 hrs, Volume= 1.768 af, Atten= 65%, Lag= 18.3 min
 Discarded = 0.46 cfs @ 12.53 hrs, Volume= 0.360 af
 Primary = 12.44 cfs @ 12.53 hrs, Volume= 1.408 af
 Routed to Pond 4K : Kettle

Routing by Dyn-Stor-Ind method, Time Span= 0.00-24.00 hrs, dt= 0.01 hrs
 Peak Elev= 954.60' @ 12.53 hrs Surf.Area= 0.831 ac Storage= 0.983 af

Plug-Flow detention time= 134.8 min calculated for 1.767 af (76% of inflow)
 Center-of-Mass det. time= 63.7 min (882.2 - 818.6)

Volume	Invert	Avail.Storage	Storage Description		
#1	952.00'	1.352 af	Custom Stage Data (Conic) Listed below (Recalc)		
Elevation (feet)	Surf.Area (acres)	Inc.Store (acre-feet)	Cum.Store (acre-feet)	Wet.Area (acres)	
952.00	0.100	0.000	0.000	0.100	
953.00	0.220	0.156	0.156	0.220	
954.00	0.610	0.399	0.555	0.610	
955.00	1.000	0.797	1.352	1.001	

Device	Routing	Invert	Outlet Devices									
#1	Discarded	952.00'	0.500 in/hr Exfiltration over Surface area Conductivity to Groundwater Elevation = 942.00' Phase-In= 0.01'									
#2	Primary	954.00'	10.0' long x 10.0' breadth Broad-Crested Rectangular Weir Head (feet) 0.20 0.40 0.60 0.80 1.00 1.20 1.40 1.60 Coef. (English) 2.49 2.56 2.70 2.69 2.68 2.69 2.67 2.64									

Discarded OutFlow Max=0.46 cfs @ 12.53 hrs HW=954.60' (Free Discharge)
 ↑1=Exfiltration (Controls 0.46 cfs)

Primary OutFlow Max=12.44 cfs @ 12.53 hrs HW=954.60' TW=949.55' (Dynamic Tailwater)
 ↑2=Broad-Crested Rectangular Weir(Weir Controls 12.44 cfs @ 2.08 fps)

Pond 5D: Depression

Hydrograph

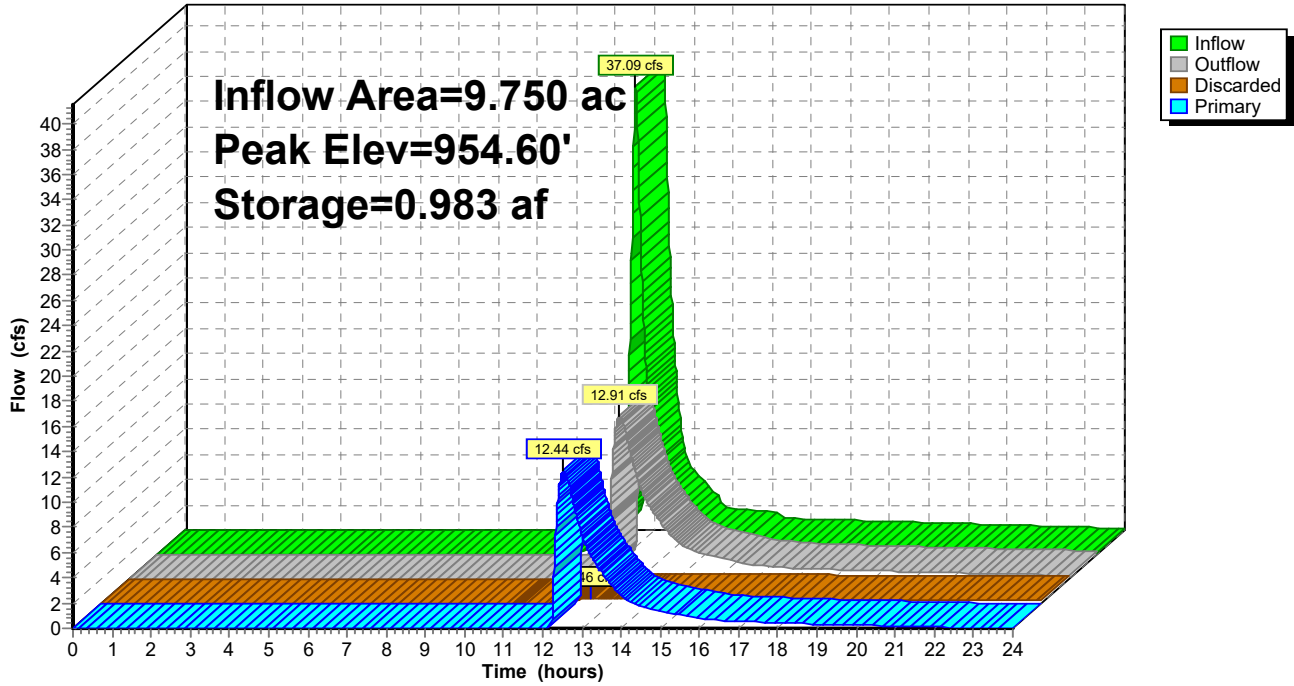

Summary for Pond 6D: Depression

Inflow Area = 6.320 ac, 4.75% Impervious, Inflow Depth > 2.66" for 100 yr event
 Inflow = 25.27 cfs @ 12.19 hrs, Volume= 1.403 af
 Outflow = 2.78 cfs @ 13.03 hrs, Volume= 0.721 af, Atten= 89%, Lag= 50.3 min
 Discarded = 0.41 cfs @ 13.03 hrs, Volume= 0.384 af
 Primary = 2.37 cfs @ 13.03 hrs, Volume= 0.337 af
 Routed to Pond 7D : Depression

Routing by Dyn-Stor-Ind method, Time Span= 0.00-24.00 hrs, dt= 0.01 hrs
 Peak Elev= 963.60' @ 13.03 hrs Surf.Area= 0.749 ac Storage= 0.811 af

Plug-Flow detention time= 237.0 min calculated for 0.721 af (51% of inflow)
 Center-of-Mass det. time= 146.8 min (966.0 - 819.2)

Volume	Invert	Avail.Storage	Storage Description	
#1	961.00'	2.337 af	Custom Stage Data (Conic) Listed below (Recalc)	
Elevation (feet)	Surf.Area (acres)	Inc.Store (acre-feet)	Cum.Store (acre-feet)	Wet.Area (acres)
961.00	0.020	0.000	0.000	0.020
962.00	0.230	0.106	0.106	0.230
963.00	0.470	0.343	0.449	0.470
964.00	0.970	0.705	1.154	0.970
965.00	1.410	1.183	2.337	1.411

Device	Routing	Invert	Outlet Devices
#1	Discarded	961.00'	0.500 in/hr Exfiltration over Surface area Conductivity to Groundwater Elevation = 951.00' Phase-In= 0.01'
#2	Primary	963.50'	30.0' long x 10.0' breadth Broad-Crested Rectangular Weir Head (feet) 0.20 0.40 0.60 0.80 1.00 1.20 1.40 1.60 Coef. (English) 2.49 2.56 2.70 2.69 2.68 2.69 2.67 2.64

Discarded OutFlow Max=0.41 cfs @ 13.03 hrs HW=963.60' (Free Discharge)
 ↑1=Exfiltration (Controls 0.41 cfs)

Primary OutFlow Max=2.37 cfs @ 13.03 hrs HW=963.60' TW=957.22' (Dynamic Tailwater)
 ↑2=Broad-Crested Rectangular Weir(Weir Controls 2.37 cfs @ 0.79 fps)

Pond 6D: Depression

Hydrograph

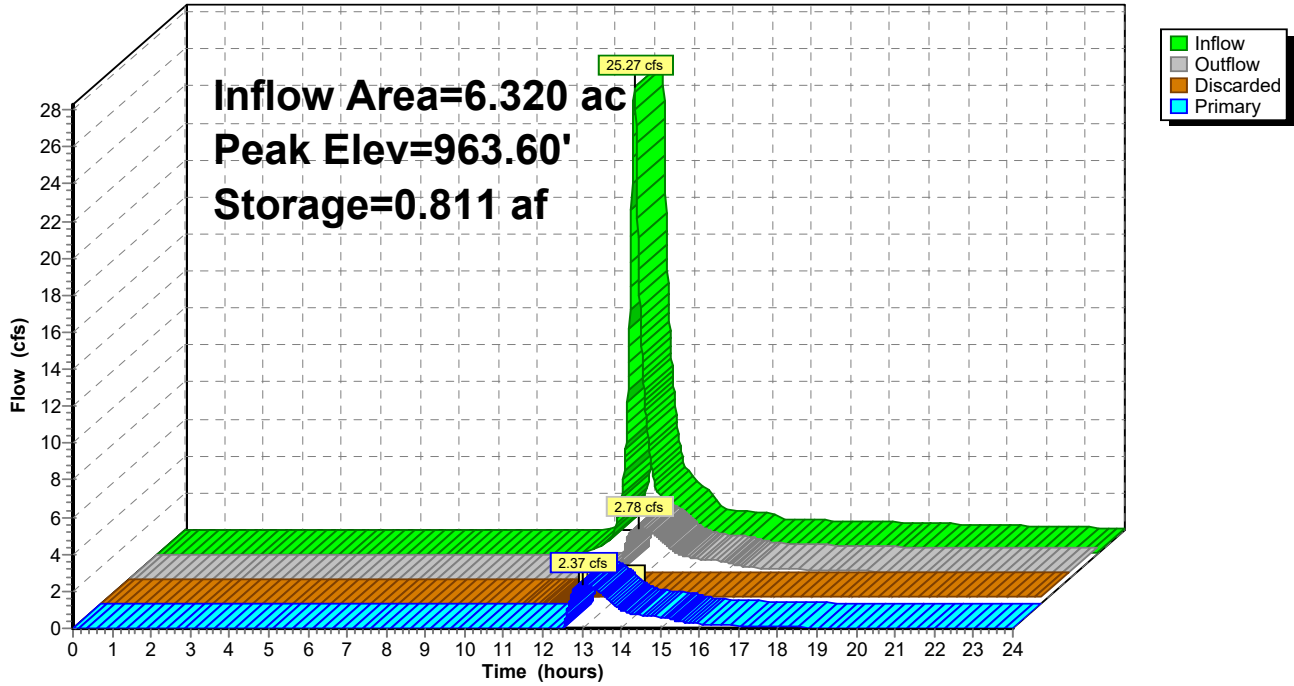

Summary for Pond 7D: Depression

Inflow Area = 15.410 ac, 4.54% Impervious, Inflow Depth > 1.67" for 100 yr event
 Inflow = 36.77 cfs @ 12.16 hrs, Volume= 2.149 af
 Outflow = 34.39 cfs @ 12.18 hrs, Volume= 2.149 af, Atten= 6%, Lag= 1.6 min
 Discarded = 0.18 cfs @ 12.18 hrs, Volume= 0.012 af
 Primary = 34.22 cfs @ 12.18 hrs, Volume= 2.136 af
 Routed to Link 1L : Discharge to County Road I

Routing by Dyn-Stor-Ind method, Time Span= 0.00-24.00 hrs, dt= 0.01 hrs
 Peak Elev= 957.62' @ 12.18 hrs Surf.Area= 0.327 ac Storage= 0.145 af

Plug-Flow detention time= 3.2 min calculated for 2.148 af (100% of inflow)
 Center-of-Mass det. time= 3.2 min (828.0 - 824.8)

Volume	Invert	Avail.Storage	Storage Description		
#1	954.30'	1.157 af	Custom Stage Data (Conic) Listed below (Recalc)		
Elevation (feet)	Surf.Area (acres)	Inc.Store (acre-feet)	Cum.Store (acre-feet)	Wet.Area (acres)	
954.30	0.000	0.000	0.000	0.000	
955.00	0.001	0.000	0.000	0.001	
956.00	0.010	0.005	0.005	0.010	
957.00	0.060	0.031	0.036	0.060	
958.00	0.600	0.283	0.320	0.600	
959.00	1.100	0.837	1.157	1.100	

Device	Routing	Invert	Outlet Devices
#1	Discarded	954.30'	0.500 in/hr Exfiltration over Surface area Conductivity to Groundwater Elevation = 951.00' Phase-In= 0.01'
#2	Primary	954.80'	15.0" Round Culvert L= 30.0' CMP, end-section conforming to fill, Ke= 0.500 Inlet / Outlet Invert= 954.30' / 954.80' S= -0.0167 '/' Cc= 0.900 n= 0.024, Flow Area= 1.23 sf
#3	Primary	957.30'	60.0' long x 10.0' breadth Broad-Crested Rectangular Weir Head (feet) 0.20 0.40 0.60 0.80 1.00 1.20 1.40 1.60 Coef. (English) 2.49 2.56 2.70 2.69 2.68 2.69 2.67 2.64

Discarded OutFlow Max=0.18 cfs @ 12.18 hrs HW=957.62' (Free Discharge)
 ↑1=Exfiltration (Controls 0.18 cfs)

Primary OutFlow Max=34.15 cfs @ 12.18 hrs HW=957.62' TW=0.00' (Dynamic Tailwater)
 ↑2=Culvert (Barrel Controls 7.18 cfs @ 5.85 fps)
 ↑3=Broad-Crested Rectangular Weir(Weir Controls 26.96 cfs @ 1.42 fps)

Pond 7D: Depression

Hydrograph

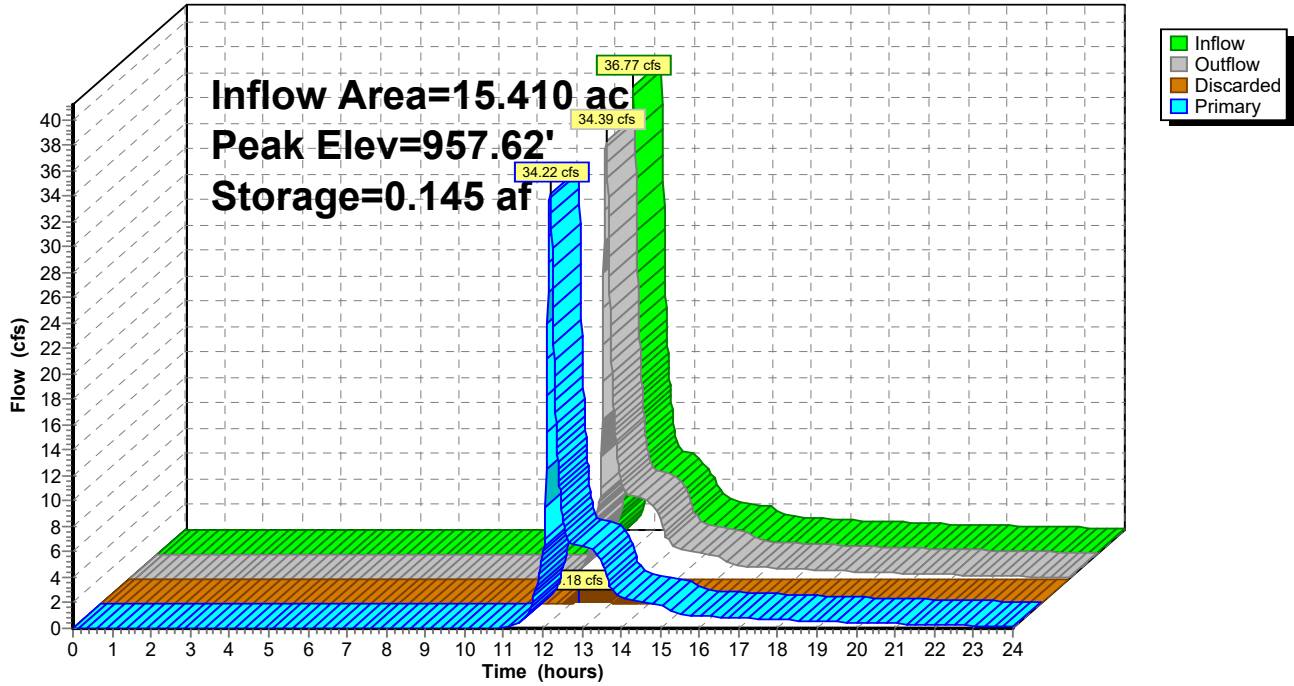

Summary for Link 1L: Discharge to County Road I

Inflow Area = 22.960 ac, 5.05% Impervious, Inflow Depth > 1.86" for 100 yr event
Inflow = 55.38 cfs @ 12.20 hrs, Volume= 3.562 af
Primary = 55.38 cfs @ 12.20 hrs, Volume= 3.562 af, Atten= 0%, Lag= 0.0 min

Primary outflow = Inflow, Time Span= 0.00-24.00 hrs, dt= 0.01 hrs

Link 1L: Discharge to County Road I

Hydrograph

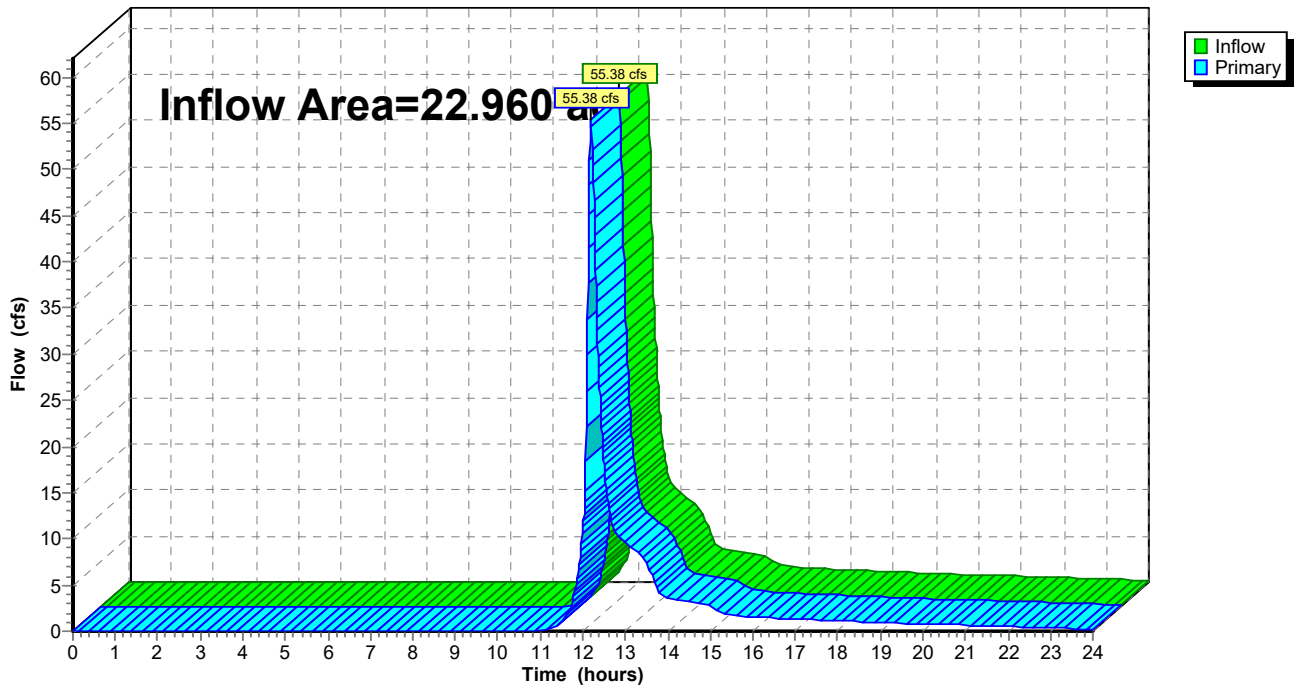

Summary for Link 2L: Discharge South

Inflow Area = 15.500 ac, 0.77% Impervious, Inflow Depth > 2.76" for 100 yr event
Inflow = 50.45 cfs @ 12.27 hrs, Volume= 3.560 af
Primary = 50.45 cfs @ 12.27 hrs, Volume= 3.560 af, Atten= 0%, Lag= 0.0 min

Primary outflow = Inflow, Time Span= 0.00-24.00 hrs, dt= 0.01 hrs

Link 2L: Discharge South

Hydrograph

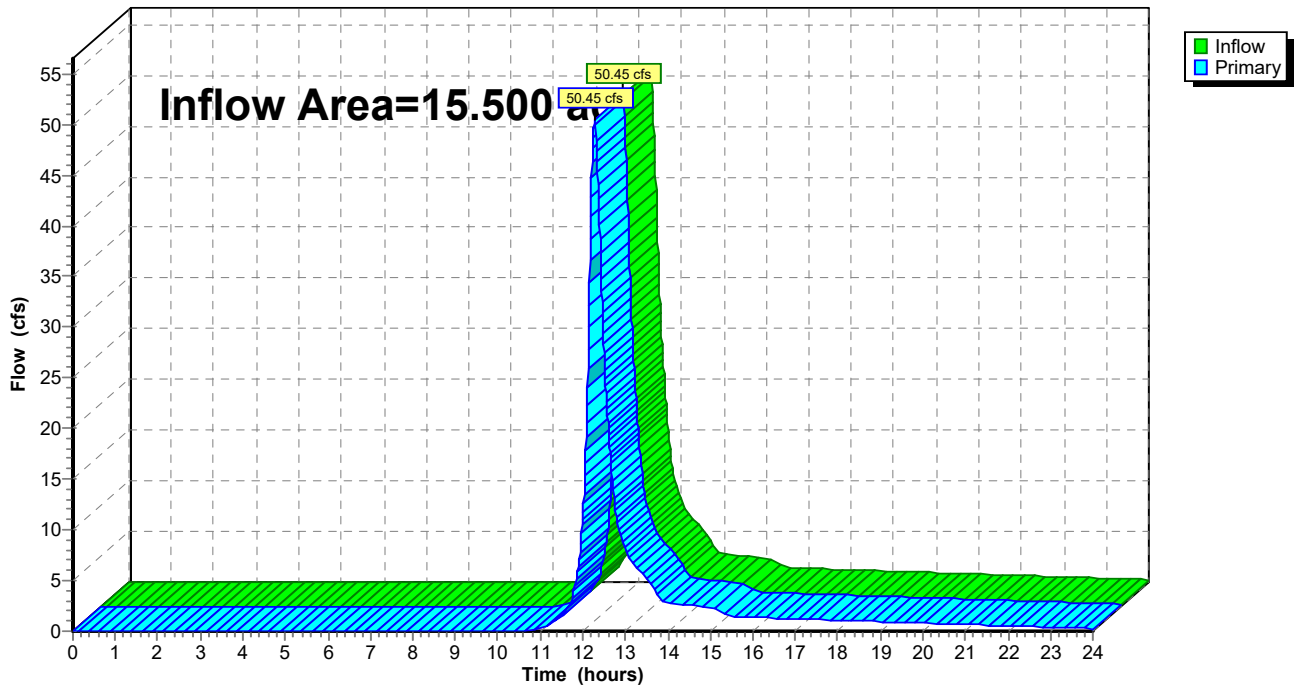

Existing_2026-002

Prepared by Sound Stormwater Design

HydroCAD® 10.20-4c s/n 11025 © 2024 HydroCAD Software Solutions LLC

Multi-Event Tables

Printed 5/12/2026

Page 120

Events for Subcatchment E1: Subarea

Event	Rainfall (inches)	Runoff (cfs)	Volume (acre-feet)	Depth (inches)
1 yr	2.40	2.04	0.166	0.32
2 yr	2.70	3.29	0.233	0.44
10 yr	3.81	9.17	0.542	1.03
100 yr	6.18	25.27	1.403	2.66

Existing_2026-002

Prepared by Sound Stormwater Design

HydroCAD® 10.20-4c s/n 11025 © 2024 HydroCAD Software Solutions LLC

Multi-Event Tables

Printed 5/12/2026

Page 121

Events for Subcatchment E2: Subarea

Event	Rainfall (inches)	Runoff (cfs)	Volume (acre-feet)	Depth (inches)
1 yr	2.40	1.97	0.178	0.24
2 yr	2.70	3.67	0.261	0.34
10 yr	3.81	12.26	0.657	0.87
100 yr	6.18	36.77	1.811	2.39

Existing_2026-002

Prepared by Sound Stormwater Design

HydroCAD® 10.20-4c s/n 11025 © 2024 HydroCAD Software Solutions LLC

Multi-Event Tables

Printed 5/12/2026

Page 122

Events for Subcatchment E3: Subarea

Event	Rainfall (inches)	Runoff (cfs)	Volume (acre-feet)	Depth (inches)
1 yr	2.40	0.83	0.098	0.24
2 yr	2.70	1.50	0.144	0.34
10 yr	3.81	5.06	0.362	0.87
100 yr	6.18	15.53	0.998	2.39

Existing_2026-002

Prepared by Sound Stormwater Design

HydroCAD® 10.20-4c s/n 11025 © 2024 HydroCAD Software Solutions LLC

Multi-Event Tables

Printed 5/12/2026

Page 123

Events for Subcatchment E4: Subarea

Event	Rainfall (inches)	Runoff (cfs)	Volume (acre-feet)	Depth (inches)
1 yr	2.40	0.18	0.025	0.19
2 yr	2.70	0.36	0.038	0.29
10 yr	3.81	1.43	0.102	0.77
100 yr	6.18	4.75	0.295	2.21

Existing_2026-002

Prepared by Sound Stormwater Design

HydroCAD® 10.20-4c s/n 11025 © 2024 HydroCAD Software Solutions LLC

Multi-Event Tables

Printed 5/12/2026

Page 124

Events for Subcatchment E5: Subarea

Event	Rainfall (inches)	Runoff (cfs)	Volume (acre-feet)	Depth (inches)
1 yr	2.40	0.02	0.006	0.08
2 yr	2.70	0.06	0.011	0.14
10 yr	3.81	0.52	0.039	0.50
100 yr	6.18	2.46	0.133	1.70

Existing_2026-002

Prepared by Sound Stormwater Design

HydroCAD® 10.20-4c s/n 11025 © 2024 HydroCAD Software Solutions LLC

Multi-Event Tables

Printed 5/12/2026

Page 125

Events for Subcatchment N1: Subarea

Event	Rainfall (inches)	Runoff (cfs)	Volume (acre-feet)	Depth (inches)
1 yr	2.40	4.41	0.467	0.31
2 yr	2.70	7.01	0.655	0.44
10 yr	3.81	19.61	1.523	1.03
100 yr	6.18	54.65	3.945	2.66

Existing_2026-002

Prepared by Sound Stormwater Design

HydroCAD® 10.20-4c s/n 11025 © 2024 HydroCAD Software Solutions LLC

Multi-Event Tables

Printed 5/12/2026

Page 126

Events for Subcatchment N2: Subarea

Event	Rainfall (inches)	Runoff (cfs)	Volume (acre-feet)	Depth (inches)
1 yr	2.40	3.73	0.240	0.41
2 yr	2.70	5.49	0.325	0.55
10 yr	3.81	13.21	0.707	1.20
100 yr	6.18	33.31	1.731	2.95

Existing_2026-002

Prepared by Sound Stormwater Design

HydroCAD® 10.20-4c s/n 11025 © 2024 HydroCAD Software Solutions LLC

Multi-Event Tables

Printed 5/12/2026

Page 127

Events for Subcatchment N3: Subarea

Event	Rainfall (inches)	Runoff (cfs)	Volume (acre-feet)	Depth (inches)
1 yr	2.40	8.02	0.913	0.41
2 yr	2.70	11.71	1.239	0.55
10 yr	3.81	28.83	2.695	1.20
100 yr	6.18	74.17	6.600	2.94

Existing_2026-002

Prepared by Sound Stormwater Design

HydroCAD® 10.20-4c s/n 11025 © 2024 HydroCAD Software Solutions LLC

Multi-Event Tables

Printed 5/12/2026

Page 128

Events for Subcatchment N4: Subarea

Event	Rainfall (inches)	Runoff (cfs)	Volume (acre-feet)	Depth (inches)
1 yr	2.40	6.34	0.501	0.29
2 yr	2.70	10.65	0.711	0.41
10 yr	3.81	31.20	1.696	0.97
100 yr	6.18	87.97	4.483	2.57

Existing_2026-002

Prepared by Sound Stormwater Design

HydroCAD® 10.20-4c s/n 11025 © 2024 HydroCAD Software Solutions LLC

Multi-Event Tables

Printed 5/12/2026

Page 129

Events for Subcatchment S1: Subarea

Event	Rainfall (inches)	Runoff (cfs)	Volume (acre-feet)	Depth (inches)
1 yr	2.40	4.51	0.445	0.34
2 yr	2.70	6.99	0.617	0.48
10 yr	3.81	18.58	1.401	1.08
100 yr	6.18	50.45	3.560	2.76

Existing_2026-002

Prepared by Sound Stormwater Design

HydroCAD® 10.20-4c s/n 11025 © 2024 HydroCAD Software Solutions LLC

Multi-Event Tables

Printed 5/12/2026

Page 130

Events for Subcatchment W1: Subarea

Event	Rainfall (inches)	Runoff (cfs)	Volume (acre-feet)	Depth (inches)
1 yr	2.40	3.69	0.305	0.38
2 yr	2.70	5.56	0.418	0.51
10 yr	3.81	14.17	0.929	1.14
100 yr	6.18	37.09	2.316	2.85

Existing_2026-002

Prepared by Sound Stormwater Design

HydroCAD® 10.20-4c s/n 11025 © 2024 HydroCAD Software Solutions LLC

Multi-Event Tables

Printed 5/12/2026

Page 131

Events for Pond 1D: Depression

Event	Inflow (cfs)	Outflow (cfs)	Discarded (cfs)	Primary (cfs)	Elevation (feet)	Storage (acre-feet)
1 yr	4.41	0.49	0.19	0.30	975.04	0.264
2 yr	7.01	1.54	0.22	1.32	975.11	0.290
10 yr	19.61	10.14	0.37	9.77	975.40	0.450
100 yr	54.65	35.47	0.73	34.74	975.91	0.961

Existing_2026-002

Prepared by Sound Stormwater Design

HydroCAD® 10.20-4c s/n 11025 © 2024 HydroCAD Software Solutions LLC

Multi-Event Tables

Printed 5/12/2026

Page 132

Events for Pond 2D: Depression

Event	Inflow (cfs)	Outflow (cfs)	Discarded (cfs)	Primary (cfs)	Elevation (feet)	Storage (acre-feet)
1 yr	3.73	0.75	0.12	0.63	970.45	0.078
2 yr	5.49	1.52	0.16	1.37	970.69	0.138
10 yr	13.21	4.93	0.31	4.62	971.78	0.619
100 yr	45.87	27.65	0.58	27.07	973.64	2.014

Existing_2026-002

Prepared by Sound Stormwater Design

HydroCAD® 10.20-4c s/n 11025 © 2024 HydroCAD Software Solutions LLC

Multi-Event Tables

Printed 5/12/2026

Page 133

Events for Pond 3D: Depression

Event	Inflow (cfs)	Outflow (cfs)	Discarded (cfs)	Primary (cfs)	Elevation (feet)	Storage (acre-feet)
1 yr	8.58	7.58	0.04	7.55	952.66	0.028
2 yr	12.64	12.61	0.05	12.56	952.81	0.041
10 yr	31.90	31.82	0.06	31.75	953.02	0.063
100 yr	80.66	80.50	0.09	80.42	953.36	0.110

Existing_2026-002

Prepared by Sound Stormwater Design

HydroCAD® 10.20-4c s/n 11025 © 2024 HydroCAD Software Solutions LLC

Multi-Event Tables

Printed 5/12/2026

Page 134

Events for Pond 4K: Kettle

Event	Inflow (cfs)	Discarded (cfs)	Elevation (feet)	Storage (acre-feet)
1 yr	10.24	0.59	946.85	1.155
2 yr	16.86	0.72	947.42	1.809
10 yr	42.94	1.20	949.45	5.054
100 yr	125.67	2.62	953.05	14.995

Existing_2026-002

Prepared by Sound Stormwater Design

HydroCAD® 10.20-4c s/n 11025 © 2024 HydroCAD Software Solutions LLC

Multi-Event Tables

Printed 5/12/2026

Page 135

Events for Pond 5D: Depression

Event	Inflow (cfs)	Outflow (cfs)	Discarded (cfs)	Primary (cfs)	Elevation (feet)	Storage (acre-feet)
1 yr	3.69	0.15	0.15	0.00	953.16	0.196
2 yr	5.56	0.19	0.19	0.00	953.42	0.276
10 yr	14.17	0.77	0.35	0.42	954.07	0.596
100 yr	37.09	12.91	0.46	12.44	954.60	0.983

Existing_2026-002

Prepared by Sound Stormwater Design

HydroCAD® 10.20-4c s/n 11025 © 2024 HydroCAD Software Solutions LLC

Multi-Event Tables

Printed 5/12/2026

Page 136

Events for Pond 6D: Depression

Event	Inflow (cfs)	Outflow (cfs)	Discarded (cfs)	Primary (cfs)	Elevation (feet)	Storage (acre-feet)
1 yr	2.04	0.11	0.11	0.00	961.95	0.094
2 yr	3.29	0.14	0.14	0.00	962.14	0.140
10 yr	9.17	0.23	0.23	0.00	962.83	0.374
100 yr	25.27	2.78	0.41	2.37	963.60	0.811

Existing_2026-002

Prepared by Sound Stormwater Design

HydroCAD® 10.20-4c s/n 11025 © 2024 HydroCAD Software Solutions LLC

Multi-Event Tables

Printed 5/12/2026

Page 137

Events for Pond 7D: Depression

Event	Inflow (cfs)	Outflow (cfs)	Discarded (cfs)	Primary (cfs)	Elevation (feet)	Storage (acre-feet)
1 yr	1.97	1.95	0.00	1.95	955.49	0.001
2 yr	3.67	3.30	0.01	3.29	955.94	0.004
10 yr	12.26	6.72	0.09	6.63	957.30	0.069
100 yr	36.77	34.39	0.18	34.22	957.62	0.145

Existing_2026-002

Prepared by Sound Stormwater Design

HydroCAD® 10.20-4c s/n 11025 © 2024 HydroCAD Software Solutions LLC

Multi-Event Tables

Printed 5/12/2026

Page 138

Events for Link 1L: Discharge to County Road I

Event	Inflow (cfs)	Primary (cfs)	Elevation (feet)
1 yr	2.66	2.66	0.00
2 yr	5.08	5.08	0.00
10 yr	13.53	13.53	0.00
100 yr	55.38	55.38	0.00

Existing_2026-002

Prepared by Sound Stormwater Design

HydroCAD® 10.20-4c s/n 11025 © 2024 HydroCAD Software Solutions LLC

Multi-Event Tables

Printed 5/12/2026

Page 139

Events for Link 2L: Discharge South

Event	Inflow (cfs)	Primary (cfs)	Elevation (feet)
1 yr	4.51	4.51	0.00
2 yr	6.99	6.99	0.00
10 yr	18.58	18.58	0.00
100 yr	50.45	50.45	0.00

APPENDIX B

Post-Development Hydrologic Analysis

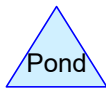
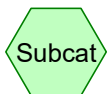
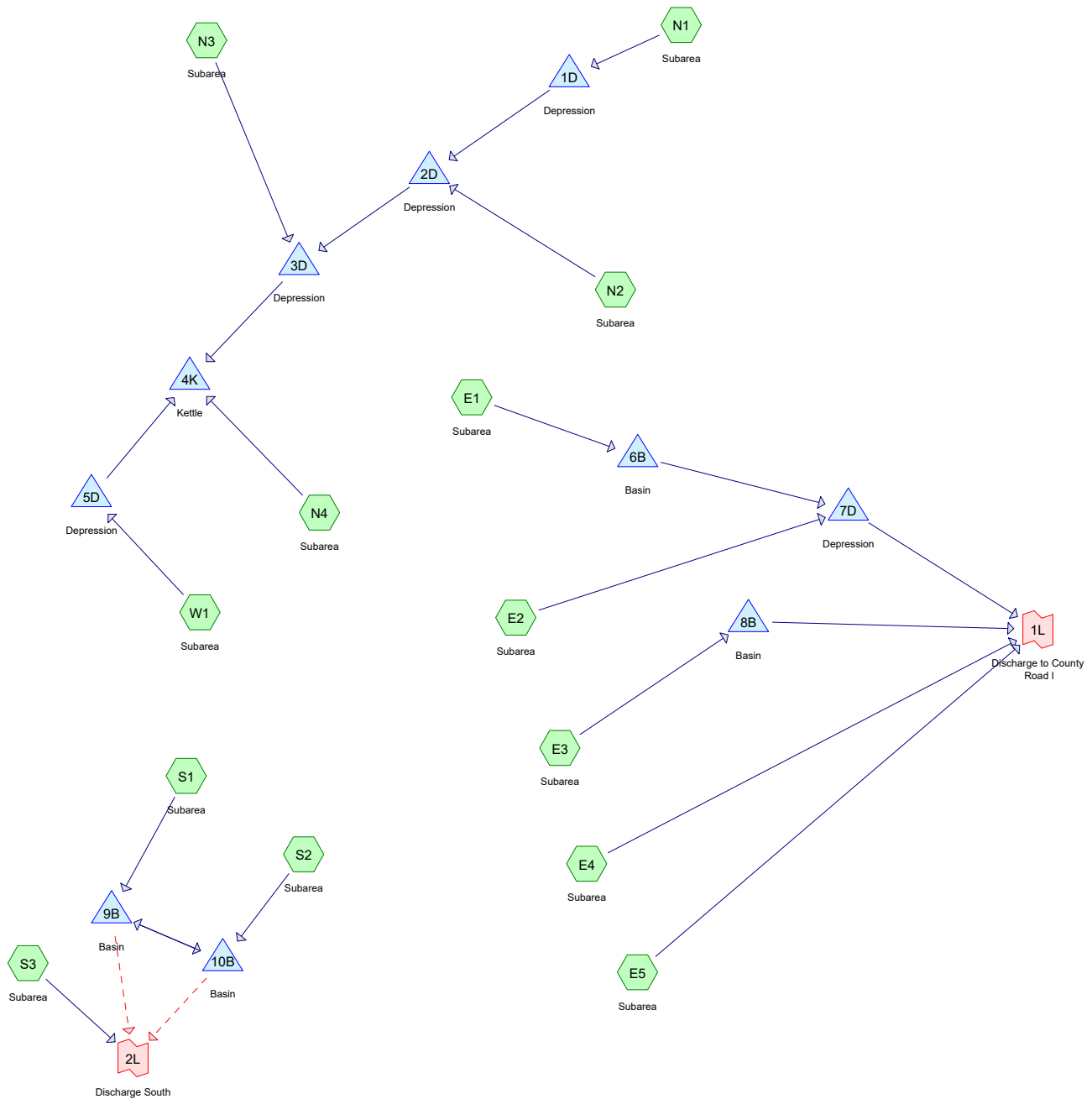

Routing Diagram for Proposed_2026-002
 Prepared by Sound Stormwater Design, Printed 5/13/2026
 HydroCAD® 10.20-4c s/n 11025 © 2024 HydroCAD Software Solutions LLC

Proposed_2026-002

Prepared by Sound Stormwater Design

HydroCAD® 10.20-4c s/n 11025 © 2024 HydroCAD Software Solutions LLC

Printed 5/13/2026

Page 2

Rainfall Events Listing (selected events)

Event#	Event Name	Storm Type	Curve	Mode	Duration (hours)	B/B	Depth (inches)	AMC
1	1 yr	MSE 24-hr	3	Default	24.00	1	2.40	2
2	2 yr	MSE 24-hr	3	Default	24.00	1	2.70	2
3	10 yr	MSE 24-hr	3	Default	24.00	1	3.81	2
4	100 yr	MSE 24-hr	3	Default	24.00	1	6.18	2

Proposed_2026-002

Prepared by Sound Stormwater Design

HydroCAD® 10.20-4c s/n 11025 © 2024 HydroCAD Software Solutions LLC

Printed 5/13/2026

Page 3

Area Listing (all nodes)

Area (acres)	CN	Description (subcatchment-numbers)
40.250	69	cropland (N1, N2, N3)
72.550	61	grass (E1, E2, E3, E4, E5, N1, N2, N3, N4, S1, S2, S3, W1)
4.490	98	impervious (E1, E3, E4, E5, N4, S1, S2, S3, W1)
3.580	98	impervious - offsite (E2, E4, N1, N2, N3, N4, W1)
120.870	66	TOTAL AREA

Proposed_2026-002

Prepared by Sound Stormwater Design

HydroCAD® 10.20-4c s/n 11025 © 2024 HydroCAD Software Solutions LLC

MSE 24-hr 3 1 yr Rainfall=2.40"

Printed 5/13/2026

Page 4

Time span=0.00-24.00 hrs, dt=0.01 hrs, 2401 points
 Runoff by SCS TR-20 method, UH=SCS, Weighted-CN
 Reach routing by Sim-Route method - Pond routing by Sim-Route method

SubcatchmentE1: Subarea	Runoff Area=12.900 ac 12.71% Impervious Runoff Depth>0.29" Flow Length=430' Slope=0.0700 '/' Tc=10.7 min CN=66 Runoff=3.58 cfs 0.309 af
SubcatchmentE2: Subarea	Runoff Area=5.960 ac 6.71% Impervious Runoff Depth>0.21" Flow Length=280' Slope=0.0800 '/' Tc=9.6 min CN=63 Runoff=0.94 cfs 0.105 af
SubcatchmentE3: Subarea	Runoff Area=4.280 ac 15.42% Impervious Runoff Depth>0.32" Flow Length=250' Slope=0.0600 '/' Tc=10.6 min CN=67 Runoff=1.41 cfs 0.112 af
SubcatchmentE4: Subarea	Runoff Area=0.950 ac 16.84% Impervious Runoff Depth>0.32" Tc=6.0 min CN=67 Runoff=0.41 cfs 0.025 af
SubcatchmentE5: Subarea	Runoff Area=1.130 ac 33.63% Impervious Runoff Depth>0.51" Flow Length=100' Slope=0.0400 '/' Tc=11.8 min CN=73 Runoff=0.74 cfs 0.048 af
SubcatchmentN1: Subarea	Runoff Area=17.780 ac 3.37% Impervious Runoff Depth>0.31" Flow Length=1,065' Tc=18.6 min CN=67 Runoff=4.41 cfs 0.467 af
SubcatchmentN2: Subarea	Runoff Area=7.050 ac 7.09% Impervious Runoff Depth>0.41" Flow Length=420' Slope=0.0700 '/' Tc=9.3 min CN=70 Runoff=3.73 cfs 0.240 af
SubcatchmentN3: Subarea	Runoff Area=26.920 ac 4.16% Impervious Runoff Depth>0.41" Flow Length=1,810' Slope=0.0400 '/' Tc=27.6 min CN=70 Runoff=8.02 cfs 0.913 af
SubcatchmentN4: Subarea	Runoff Area=20.700 ac 4.40% Impervious Runoff Depth>0.21" Flow Length=260' Slope=0.0600 '/' Tc=10.7 min CN=63 Runoff=3.15 cfs 0.364 af
SubcatchmentS1: Subarea	Runoff Area=11.340 ac 11.64% Impervious Runoff Depth>0.26" Flow Length=830' Tc=14.8 min CN=65 Runoff=2.26 cfs 0.246 af
SubcatchmentS2: Subarea	Runoff Area=3.470 ac 1.44% Impervious Runoff Depth>0.19" Flow Length=340' Tc=14.3 min CN=62 Runoff=0.38 cfs 0.054 af
SubcatchmentS3: Subarea	Runoff Area=1.950 ac 10.77% Impervious Runoff Depth>0.26" Flow Length=200' Slope=0.0900 '/' Tc=8.8 min CN=65 Runoff=0.50 cfs 0.042 af
SubcatchmentW1: Subarea	Runoff Area=6.440 ac 1.86% Impervious Runoff Depth>0.19" Flow Length=500' Slope=0.0900 '/' Tc=9.9 min CN=62 Runoff=0.79 cfs 0.101 af
Pond 1D: Depression	Peak Elev=975.04' Storage=0.264 af Inflow=4.41 cfs 0.467 af Discarded=0.19 cfs 0.166 af Primary=0.30 cfs 0.065 af Outflow=0.49 cfs 0.232 af
Pond 2D: Depression	Peak Elev=970.46' Storage=0.078 af Inflow=3.73 cfs 0.305 af Discarded=0.12 cfs 0.088 af Primary=0.63 cfs 0.211 af Outflow=0.75 cfs 0.299 af
Pond 3D: Depression	Peak Elev=952.66' Storage=0.029 af Inflow=8.58 cfs 1.124 af Discarded=0.04 cfs 0.002 af Primary=7.56 cfs 1.465 af Outflow=7.59 cfs 1.467 af

Proposed_2026-002

Prepared by Sound Stormwater Design

HydroCAD® 10.20-4c s/n 11025 © 2024 HydroCAD Software Solutions LLC

MSE 24-hr 3 1 yr Rainfall=2.40"

Printed 5/13/2026

Page 5

Pond 4K: Kettle Peak Elev=946.98' Storage=1.297 af Inflow=9.45 cfs 1.829 af
Outflow=0.62 cfs 0.542 af

Pond 5D: Depression Peak Elev=952.40' Storage=0.048 af Inflow=0.79 cfs 0.101 af
Discarded=0.07 cfs 0.070 af Primary=0.00 cfs 0.000 af Outflow=0.07 cfs 0.070 af

Pond 6B: Basin Peak Elev=958.56' Storage=0.224 af Inflow=3.58 cfs 0.309 af
Discarded=0.09 cfs 0.086 af Primary=0.01 cfs 0.007 af Outflow=0.10 cfs 0.093 af

Pond 7D: Depression Peak Elev=955.26' Storage=0.001 af Inflow=0.94 cfs 0.112 af
Discarded=0.00 cfs 0.000 af Primary=0.94 cfs 0.111 af Outflow=0.95 cfs 0.112 af

Pond 8B: Basin Peak Elev=972.51' Storage=0.046 af Inflow=1.41 cfs 0.112 af
Discarded=0.01 cfs 0.011 af Primary=0.21 cfs 0.074 af Outflow=0.23 cfs 0.085 af

Pond 9B: Basin Peak Elev=962.19' Storage=0.097 af Inflow=2.26 cfs 0.246 af
Discarded=0.28 cfs 0.234 af Primary=0.03 cfs 0.011 af Secondary=0.00 cfs 0.000 af Outflow=0.31 cfs 0.245 af

Pond 10B: Basin Peak Elev=962.04' Storage=0.011 af Inflow=0.38 cfs 0.066 af
Discarded=0.14 cfs 0.066 af Primary=0.00 cfs 0.000 af Secondary=0.00 cfs 0.000 af Outflow=0.14 cfs 0.066 af

Link 1L: Discharge to County Road I Inflow=1.94 cfs 0.259 af
Primary=1.94 cfs 0.259 af

Link 2L: Discharge South Inflow=0.50 cfs 0.042 af
Primary=0.50 cfs 0.042 af

Total Runoff Area = 120.870 ac Runoff Volume = 3.027 af Average Runoff Depth = 0.30"
93.32% Pervious = 112.800 ac 6.68% Impervious = 8.070 ac

Proposed_2026-002

Prepared by Sound Stormwater Design

HydroCAD® 10.20-4c s/n 11025 © 2024 HydroCAD Software Solutions LLC

MSE 24-hr 3 2 yr Rainfall=2.70"

Printed 5/13/2026

Page 41

Time span=0.00-24.00 hrs, dt=0.01 hrs, 2401 points
 Runoff by SCS TR-20 method, UH=SCS, Weighted-CN
 Reach routing by Sim-Route method - Pond routing by Sim-Route method

SubcatchmentE1: Subarea	Runoff Area=12.900 ac 12.71% Impervious Runoff Depth>0.41" Flow Length=430' Slope=0.0700 '/' Tc=10.7 min CN=66 Runoff=6.00 cfs 0.439 af
SubcatchmentE2: Subarea	Runoff Area=5.960 ac 6.71% Impervious Runoff Depth>0.31" Flow Length=280' Slope=0.0800 '/' Tc=9.6 min CN=63 Runoff=1.86 cfs 0.156 af
SubcatchmentE3: Subarea	Runoff Area=4.280 ac 15.42% Impervious Runoff Depth>0.44" Flow Length=250' Slope=0.0600 '/' Tc=10.6 min CN=67 Runoff=2.26 cfs 0.158 af
SubcatchmentE4: Subarea	Runoff Area=0.950 ac 16.84% Impervious Runoff Depth>0.44" Tc=6.0 min CN=67 Runoff=0.66 cfs 0.035 af
SubcatchmentE5: Subarea	Runoff Area=1.130 ac 33.63% Impervious Runoff Depth>0.68" Flow Length=100' Slope=0.0400 '/' Tc=11.8 min CN=73 Runoff=1.02 cfs 0.064 af
SubcatchmentN1: Subarea	Runoff Area=17.780 ac 3.37% Impervious Runoff Depth>0.44" Flow Length=1,065' Tc=18.6 min CN=67 Runoff=7.01 cfs 0.655 af
SubcatchmentN2: Subarea	Runoff Area=7.050 ac 7.09% Impervious Runoff Depth>0.55" Flow Length=420' Slope=0.0700 '/' Tc=9.3 min CN=70 Runoff=5.49 cfs 0.325 af
SubcatchmentN3: Subarea	Runoff Area=26.920 ac 4.16% Impervious Runoff Depth>0.55" Flow Length=1,810' Slope=0.0400 '/' Tc=27.6 min CN=70 Runoff=11.71 cfs 1.239 af
SubcatchmentN4: Subarea	Runoff Area=20.700 ac 4.40% Impervious Runoff Depth>0.31" Flow Length=260' Slope=0.0600 '/' Tc=10.7 min CN=63 Runoff=6.13 cfs 0.542 af
SubcatchmentS1: Subarea	Runoff Area=11.340 ac 11.64% Impervious Runoff Depth>0.38" Flow Length=830' Tc=14.8 min CN=65 Runoff=3.90 cfs 0.355 af
SubcatchmentS2: Subarea	Runoff Area=3.470 ac 1.44% Impervious Runoff Depth>0.29" Flow Length=340' Tc=14.3 min CN=62 Runoff=0.75 cfs 0.082 af
SubcatchmentS3: Subarea	Runoff Area=1.950 ac 10.77% Impervious Runoff Depth>0.38" Flow Length=200' Slope=0.0900 '/' Tc=8.8 min CN=65 Runoff=0.87 cfs 0.061 af
SubcatchmentW1: Subarea	Runoff Area=6.440 ac 1.86% Impervious Runoff Depth>0.29" Flow Length=500' Slope=0.0900 '/' Tc=9.9 min CN=62 Runoff=1.65 cfs 0.153 af
Pond 1D: Depression	Peak Elev=975.11' Storage=0.290 af Inflow=7.01 cfs 0.655 af Discarded=0.22 cfs 0.177 af Primary=1.33 cfs 0.235 af Outflow=1.55 cfs 0.413 af
Pond 2D: Depression	Peak Elev=970.69' Storage=0.139 af Inflow=5.49 cfs 0.561 af Discarded=0.16 cfs 0.103 af Primary=1.37 cfs 0.447 af Outflow=1.53 cfs 0.550 af
Pond 3D: Depression	Peak Elev=952.81' Storage=0.041 af Inflow=12.64 cfs 1.686 af Discarded=0.05 cfs 0.003 af Primary=12.59 cfs 1.987 af Outflow=12.63 cfs 1.990 af

Proposed_2026-002

Prepared by Sound Stormwater Design

HydroCAD® 10.20-4c s/n 11025 © 2024 HydroCAD Software Solutions LLC

MSE 24-hr 3 2 yr Rainfall=2.70"

Printed 5/13/2026

Page 42

Pond 4K: Kettle Peak Elev=947.48' Storage=1.889 af Inflow=16.12 cfs 2.528 af
Outflow=0.73 cfs 0.648 af

Pond 5D: Depression Peak Elev=952.64' Storage=0.086 af Inflow=1.65 cfs 0.153 af
Discarded=0.09 cfs 0.085 af Primary=0.00 cfs 0.000 af Outflow=0.09 cfs 0.085 af

Pond 6B: Basin Peak Elev=958.66' Storage=0.300 af Inflow=6.00 cfs 0.439 af
Discarded=0.09 cfs 0.089 af Primary=0.11 cfs 0.077 af Outflow=0.20 cfs 0.166 af

Pond 7D: Depression Peak Elev=955.47' Storage=0.001 af Inflow=1.86 cfs 0.233 af
Discarded=0.00 cfs 0.001 af Primary=1.86 cfs 0.232 af Outflow=1.86 cfs 0.233 af

Pond 8B: Basin Peak Elev=972.62' Storage=0.058 af Inflow=2.26 cfs 0.158 af
Discarded=0.01 cfs 0.011 af Primary=0.41 cfs 0.118 af Outflow=0.42 cfs 0.129 af

Pond 9B: Basin Peak Elev=962.32' Storage=0.162 af Inflow=3.90 cfs 0.355 af
Discarded=0.29 cfs 0.274 af Primary=0.11 cfs 0.050 af Secondary=0.00 cfs 0.000 af Outflow=0.40 cfs 0.324 af

Pond 10B: Basin Peak Elev=962.15' Storage=0.042 af Inflow=0.76 cfs 0.133 af
Discarded=0.15 cfs 0.133 af Primary=0.00 cfs 0.000 af Secondary=0.00 cfs 0.000 af Outflow=0.15 cfs 0.133 af

Link 1L: Discharge to County Road I Inflow=3.31 cfs 0.449 af
Primary=3.31 cfs 0.449 af

Link 2L: Discharge South Inflow=0.87 cfs 0.061 af
Primary=0.87 cfs 0.061 af

Total Runoff Area = 120.870 ac Runoff Volume = 4.264 af Average Runoff Depth = 0.42"
93.32% Pervious = 112.800 ac 6.68% Impervious = 8.070 ac

Proposed_2026-002

MSE 24-hr 3 10 yr Rainfall=3.81"

Prepared by Sound Stormwater Design

Printed 5/13/2026

HydroCAD® 10.20-4c s/n 11025 © 2024 HydroCAD Software Solutions LLC

Page 78

Time span=0.00-24.00 hrs, dt=0.01 hrs, 2401 points
 Runoff by SCS TR-20 method, UH=SCS, Weighted-CN
 Reach routing by Sim-Route method - Pond routing by Sim-Route method

SubcatchmentE1: Subarea	Runoff Area=12.900 ac 12.71% Impervious Runoff Depth>0.97" Flow Length=430' Slope=0.0700 '/' Tc=10.7 min CN=66 Runoff=17.66 cfs 1.046 af
SubcatchmentE2: Subarea	Runoff Area=5.960 ac 6.71% Impervious Runoff Depth>0.82" Flow Length=280' Slope=0.0800 '/' Tc=9.6 min CN=63 Runoff=6.84 cfs 0.405 af
SubcatchmentE3: Subarea	Runoff Area=4.280 ac 15.42% Impervious Runoff Depth>1.03" Flow Length=250' Slope=0.0600 '/' Tc=10.6 min CN=67 Runoff=6.29 cfs 0.367 af
SubcatchmentE4: Subarea	Runoff Area=0.950 ac 16.84% Impervious Runoff Depth>1.03" Tc=6.0 min CN=67 Runoff=1.76 cfs 0.081 af
SubcatchmentE5: Subarea	Runoff Area=1.130 ac 33.63% Impervious Runoff Depth>1.39" Flow Length=100' Slope=0.0400 '/' Tc=11.8 min CN=73 Runoff=2.24 cfs 0.131 af
SubcatchmentN1: Subarea	Runoff Area=17.780 ac 3.37% Impervious Runoff Depth>1.03" Flow Length=1,065' Tc=18.6 min CN=67 Runoff=19.61 cfs 1.523 af
SubcatchmentN2: Subarea	Runoff Area=7.050 ac 7.09% Impervious Runoff Depth>1.20" Flow Length=420' Slope=0.0700 '/' Tc=9.3 min CN=70 Runoff=13.21 cfs 0.707 af
SubcatchmentN3: Subarea	Runoff Area=26.920 ac 4.16% Impervious Runoff Depth>1.20" Flow Length=1,810' Slope=0.0400 '/' Tc=27.6 min CN=70 Runoff=28.83 cfs 2.695 af
SubcatchmentN4: Subarea	Runoff Area=20.700 ac 4.40% Impervious Runoff Depth>0.82" Flow Length=260' Slope=0.0600 '/' Tc=10.7 min CN=63 Runoff=22.55 cfs 1.407 af
SubcatchmentS1: Subarea	Runoff Area=11.340 ac 11.64% Impervious Runoff Depth>0.92" Flow Length=830' Tc=14.8 min CN=65 Runoff=12.28 cfs 0.868 af
SubcatchmentS2: Subarea	Runoff Area=3.470 ac 1.44% Impervious Runoff Depth>0.77" Flow Length=340' Tc=14.3 min CN=62 Runoff=2.99 cfs 0.221 af
SubcatchmentS3: Subarea	Runoff Area=1.950 ac 10.77% Impervious Runoff Depth>0.92" Flow Length=200' Slope=0.0900 '/' Tc=8.8 min CN=65 Runoff=2.72 cfs 0.149 af
SubcatchmentW1: Subarea	Runoff Area=6.440 ac 1.86% Impervious Runoff Depth>0.77" Flow Length=500' Slope=0.0900 '/' Tc=9.9 min CN=62 Runoff=6.71 cfs 0.411 af
Pond 1D: Depression	Peak Elev=975.40' Storage=0.452 af Inflow=19.61 cfs 1.523 af Discarded=0.37 cfs 0.202 af Primary=9.87 cfs 1.068 af Outflow=10.24 cfs 1.271 af
Pond 2D: Depression	Peak Elev=971.78' Storage=0.621 af Inflow=13.21 cfs 1.775 af Discarded=0.31 cfs 0.162 af Primary=4.63 cfs 1.588 af Outflow=4.94 cfs 1.750 af
Pond 3D: Depression	Peak Elev=953.02' Storage=0.063 af Inflow=31.86 cfs 4.283 af Discarded=0.06 cfs 0.010 af Primary=31.75 cfs 4.473 af Outflow=31.82 cfs 4.483 af

Proposed_2026-002

MSE 24-hr 3 10 yr Rainfall=3.81"

Prepared by Sound Stormwater Design

Printed 5/13/2026

HydroCAD® 10.20-4c s/n 11025 © 2024 HydroCAD Software Solutions LLC

Page 79

Pond 4K: Kettle Peak Elev=949.33' Storage=4.836 af Inflow=42.06 cfs 5.880 af
Outflow=1.17 cfs 1.055 af

Pond 5D: Depression Peak Elev=953.41' Storage=0.272 af Inflow=6.71 cfs 0.411 af
Discarded=0.19 cfs 0.177 af Primary=0.00 cfs 0.000 af Outflow=0.19 cfs 0.177 af

Pond 6B: Basin Peak Elev=959.03' Storage=0.595 af Inflow=17.66 cfs 1.046 af
Discarded=0.10 cfs 0.099 af Primary=1.05 cfs 0.589 af Outflow=1.16 cfs 0.688 af

Pond 7D: Depression Peak Elev=956.69' Storage=0.021 af Inflow=6.84 cfs 0.994 af
Discarded=0.02 cfs 0.002 af Primary=5.35 cfs 0.992 af Outflow=5.37 cfs 0.993 af

Pond 8B: Basin Peak Elev=973.23' Storage=0.136 af Inflow=6.29 cfs 0.367 af
Discarded=0.02 cfs 0.012 af Primary=1.35 cfs 0.323 af Outflow=1.37 cfs 0.335 af

Pond 9B: Basin Peak Elev=962.85' Storage=0.444 af Inflow=12.28 cfs 0.868 af
Discarded=0.36 cfs 0.350 af Primary=0.97 cfs 0.158 af Secondary=0.00 cfs 0.000 af Outflow=1.33 cfs 0.508 af

Pond 10B: Basin Peak Elev=962.85' Storage=0.258 af Inflow=3.05 cfs 0.380 af
Discarded=0.18 cfs 0.172 af Primary=0.00 cfs 0.000 af Secondary=0.00 cfs 0.000 af Outflow=0.18 cfs 0.172 af

Link 1L: Discharge to County Road I Inflow=9.15 cfs 1.527 af
Primary=9.15 cfs 1.527 af

Link 2L: Discharge South Inflow=2.72 cfs 0.149 af
Primary=2.72 cfs 0.149 af

Total Runoff Area = 120.870 ac Runoff Volume = 10.012 af Average Runoff Depth = 0.99"
93.32% Pervious = 112.800 ac 6.68% Impervious = 8.070 ac

Proposed_2026-002*MSE 24-hr 3 100 yr Rainfall=6.18"*

Prepared by Sound Stormwater Design

Printed 5/13/2026

HydroCAD® 10.20-4c s/n 11025 © 2024 HydroCAD Software Solutions LLC

Page 115

Time span=0.00-24.00 hrs, dt=0.01 hrs, 2401 points
 Runoff by SCS TR-20 method, UH=SCS, Weighted-CN
 Reach routing by Sim-Route method - Pond routing by Sim-Route method

SubcatchmentE1: Subarea	Runoff Area=12.900 ac 12.71% Impervious Runoff Depth>2.57" Flow Length=430' Slope=0.0700 '/' Tc=10.7 min CN=66 Runoff=50.14 cfs 2.765 af
SubcatchmentE2: Subarea	Runoff Area=5.960 ac 6.71% Impervious Runoff Depth>2.30" Flow Length=280' Slope=0.0800 '/' Tc=9.6 min CN=63 Runoff=21.49 cfs 1.143 af
SubcatchmentE3: Subarea	Runoff Area=4.280 ac 15.42% Impervious Runoff Depth>2.66" Flow Length=250' Slope=0.0600 '/' Tc=10.6 min CN=67 Runoff=17.29 cfs 0.950 af
SubcatchmentE4: Subarea	Runoff Area=0.950 ac 16.84% Impervious Runoff Depth>2.67" Tc=6.0 min CN=67 Runoff=4.73 cfs 0.211 af
SubcatchmentE5: Subarea	Runoff Area=1.130 ac 33.63% Impervious Runoff Depth>3.24" Flow Length=100' Slope=0.0400 '/' Tc=11.8 min CN=73 Runoff=5.29 cfs 0.305 af
SubcatchmentN1: Subarea	Runoff Area=17.780 ac 3.37% Impervious Runoff Depth>2.66" Flow Length=1,065' Tc=18.6 min CN=67 Runoff=54.65 cfs 3.945 af
SubcatchmentN2: Subarea	Runoff Area=7.050 ac 7.09% Impervious Runoff Depth>2.95" Flow Length=420' Slope=0.0700 '/' Tc=9.3 min CN=70 Runoff=33.31 cfs 1.731 af
SubcatchmentN3: Subarea	Runoff Area=26.920 ac 4.16% Impervious Runoff Depth>2.94" Flow Length=1,810' Slope=0.0400 '/' Tc=27.6 min CN=70 Runoff=74.17 cfs 6.600 af
SubcatchmentN4: Subarea	Runoff Area=20.700 ac 4.40% Impervious Runoff Depth>2.30" Flow Length=260' Slope=0.0600 '/' Tc=10.7 min CN=63 Runoff=71.35 cfs 3.969 af
SubcatchmentS1: Subarea	Runoff Area=11.340 ac 11.64% Impervious Runoff Depth>2.48" Flow Length=830' Tc=14.8 min CN=65 Runoff=36.34 cfs 2.344 af
SubcatchmentS2: Subarea	Runoff Area=3.470 ac 1.44% Impervious Runoff Depth>2.21" Flow Length=340' Tc=14.3 min CN=62 Runoff=9.93 cfs 0.640 af
SubcatchmentS3: Subarea	Runoff Area=1.950 ac 10.77% Impervious Runoff Depth>2.48" Flow Length=200' Slope=0.0900 '/' Tc=8.8 min CN=65 Runoff=7.91 cfs 0.403 af
SubcatchmentW1: Subarea	Runoff Area=6.440 ac 1.86% Impervious Runoff Depth>2.21" Flow Length=500' Slope=0.0900 '/' Tc=9.9 min CN=62 Runoff=22.07 cfs 1.188 af
Pond 1D: Depression	Peak Elev=975.91' Storage=0.968 af Inflow=54.65 cfs 3.945 af Discarded=0.74 cfs 0.252 af Primary=35.00 cfs 3.433 af Outflow=35.74 cfs 3.686 af
Pond 2D: Depression	Peak Elev=973.64' Storage=2.017 af Inflow=45.43 cfs 5.165 af Discarded=0.58 cfs 0.316 af Primary=27.68 cfs 4.793 af Outflow=28.27 cfs 5.109 af
Pond 3D: Depression	Peak Elev=953.36' Storage=0.110 af Inflow=80.62 cfs 11.393 af Discarded=0.09 cfs 0.048 af Primary=80.51 cfs 11.341 af Outflow=80.59 cfs 11.389 af

Proposed_2026-002

Prepared by Sound Stormwater Design

HydroCAD® 10.20-4c s/n 11025 © 2024 HydroCAD Software Solutions LLC

MSE 24-hr 3 100 yr Rainfall=6.18"

Printed 5/13/2026

Page 116

Pond 4K: Kettle Peak Elev=952.70' Storage=13.641 af Inflow=116.12 cfs 15.646 af
Outflow=2.40 cfs 2.111 af

Pond 5D: Depression Peak Elev=954.17' Storage=0.665 af Inflow=22.07 cfs 1.187 af
Discarded=0.37 cfs 0.337 af Primary=1.78 cfs 0.336 af Outflow=2.15 cfs 0.673 af

Pond 6B: Basin Peak Elev=960.14' Storage=1.541 af Inflow=50.14 cfs 2.765 af
Discarded=0.14 cfs 0.120 af Primary=4.03 cfs 2.178 af Outflow=4.17 cfs 2.298 af

Pond 7D: Depression Peak Elev=957.51' Storage=0.113 af Inflow=22.73 cfs 3.321 af
Discarded=0.14 cfs 0.016 af Primary=21.22 cfs 3.305 af Outflow=21.36 cfs 3.321 af

Pond 8B: Basin Peak Elev=974.80' Storage=0.436 af Inflow=17.29 cfs 0.950 af
Discarded=0.03 cfs 0.017 af Primary=2.50 cfs 0.897 af Outflow=2.53 cfs 0.914 af

Pond 9B: Basin Peak Elev=963.98' Storage=1.111 af Inflow=36.34 cfs 2.454 af
Discarded=0.52 cfs 0.504 af Primary=3.64 cfs 0.251 af Secondary=3.36 cfs 0.767 af Outflow=7.13 cfs 1.522 af

Pond 10B: Basin Peak Elev=963.95' Storage=0.661 af Inflow=11.45 cfs 0.891 af
Discarded=0.23 cfs 0.223 af Primary=0.56 cfs 0.110 af Secondary=0.00 cfs 0.000 af Outflow=0.79 cfs 0.333 af

Link 1L: Discharge to County Road I Inflow=30.98 cfs 4.717 af
Primary=30.98 cfs 4.717 af

Link 2L: Discharge South Inflow=7.91 cfs 1.170 af
Primary=7.91 cfs 1.170 af

Total Runoff Area = 120.870 ac Runoff Volume = 26.195 af Average Runoff Depth = 2.60"
93.32% Pervious = 112.800 ac 6.68% Impervious = 8.070 ac

Proposed_2026-002

Prepared by Sound Stormwater Design

HydroCAD® 10.20-4c s/n 11025 © 2024 HydroCAD Software Solutions LLC

MSE 24-hr 3 100 yr Rainfall=6.18"

Printed 5/13/2026

Page 117

Summary for Subcatchment E1: Subarea

Runoff = 50.14 cfs @ 12.19 hrs, Volume= 2.765 af, Depth> 2.57"
 Routed to Pond 6B : Basin

Runoff by SCS TR-20 method, UH=SCS, Weighted-CN, Time Span= 0.00-24.00 hrs, dt= 0.01 hrs
 MSE 24-hr 3 100 yr Rainfall=6.18"

Area (ac)	CN	Description
* 11.260	61	grass
* 1.640	98	impervious
12.900	66	Weighted Average
11.260		87.29% Pervious Area
1.640		12.71% Impervious Area

Tc (min)	Length (feet)	Slope (ft/ft)	Velocity (ft/sec)	Capacity (cfs)	Description
9.4	100	0.0700	0.18		Sheet Flow, Grass: Dense n= 0.240 P2= 2.70"
1.3	330	0.0700	4.26		Shallow Concentrated Flow, Unpaved Kv= 16.1 fps
10.7	430	Total			

Subcatchment E1: Subarea

Hydrograph

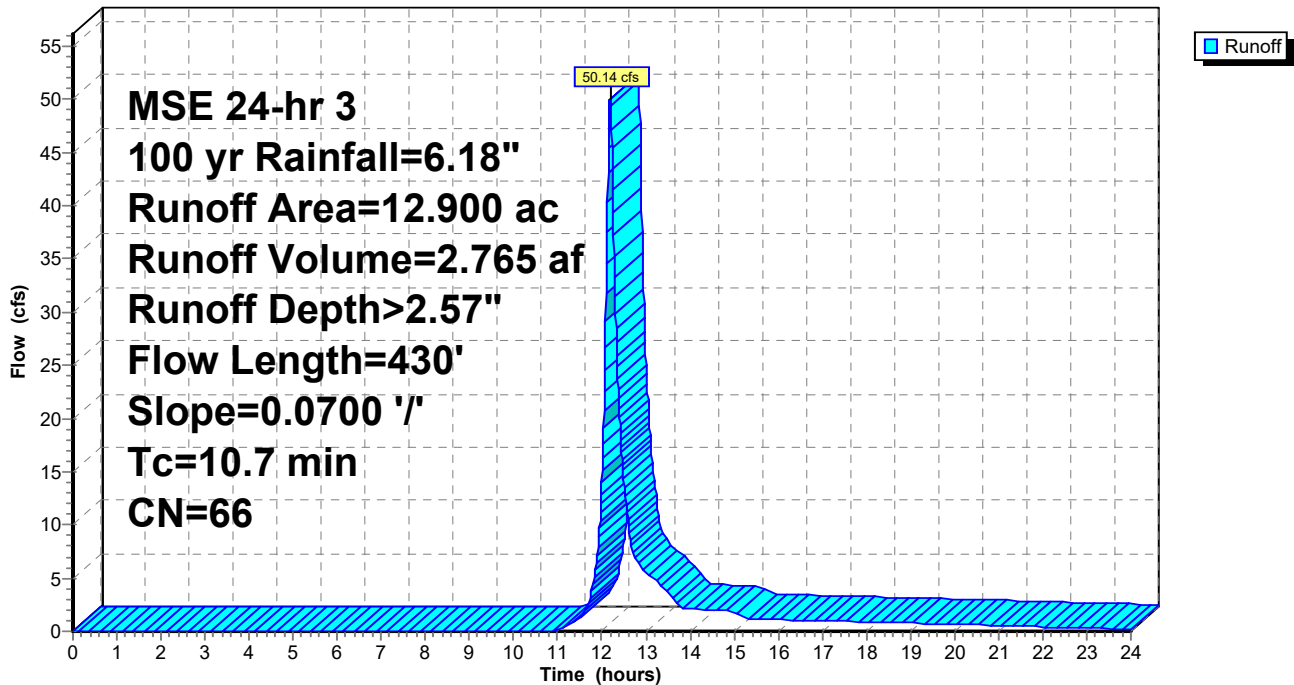

Proposed_2026-002

Prepared by Sound Stormwater Design

HydroCAD® 10.20-4c s/n 11025 © 2024 HydroCAD Software Solutions LLC

MSE 24-hr 3 100 yr Rainfall=6.18"

Printed 5/13/2026

Page 118

Summary for Subcatchment E2: Subarea

Runoff = 21.49 cfs @ 12.18 hrs, Volume= 1.143 af, Depth> 2.30"

Routed to Pond 7D : Depression

Runoff by SCS TR-20 method, UH=SCS, Weighted-CN, Time Span= 0.00-24.00 hrs, dt= 0.01 hrs
MSE 24-hr 3 100 yr Rainfall=6.18"

Area (ac)	CN	Description
* 5.560	61	grass
* 0.400	98	impervious - offsite
5.960	63	Weighted Average
5.560		93.29% Pervious Area
0.400		6.71% Impervious Area

Tc (min)	Length (feet)	Slope (ft/ft)	Velocity (ft/sec)	Capacity (cfs)	Description
8.9	100	0.0800	0.19		Sheet Flow, Grass: Dense n= 0.240 P2= 2.70"
0.7	180	0.0800	4.55		Shallow Concentrated Flow, Unpaved Kv= 16.1 fps
9.6	280	Total			

Subcatchment E2: Subarea

Hydrograph

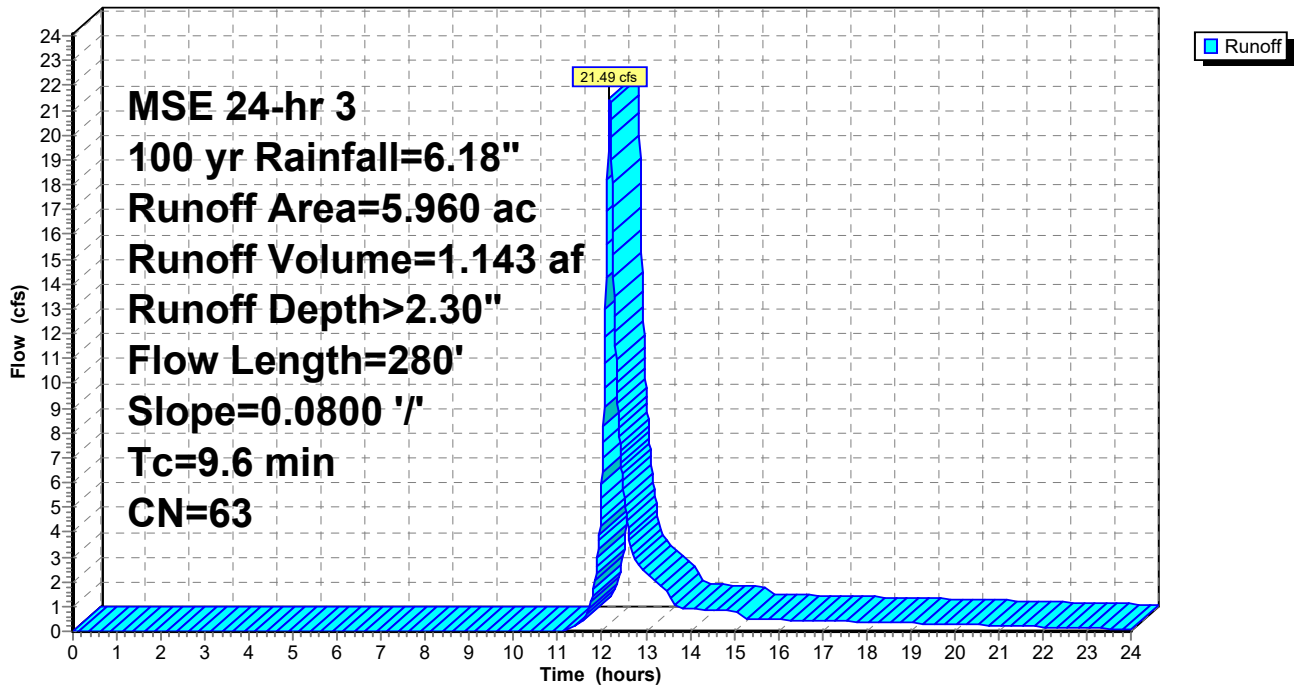

Proposed_2026-002

Prepared by Sound Stormwater Design

HydroCAD® 10.20-4c s/n 11025 © 2024 HydroCAD Software Solutions LLC

MSE 24-hr 3 100 yr Rainfall=6.18"

Printed 5/13/2026

Page 119

Summary for Subcatchment E3: Subarea

Runoff = 17.29 cfs @ 12.19 hrs, Volume= 0.950 af, Depth> 2.66"
Routed to Pond 8B : Basin

Runoff by SCS TR-20 method, UH=SCS, Weighted-CN, Time Span= 0.00-24.00 hrs, dt= 0.01 hrs
MSE 24-hr 3 100 yr Rainfall=6.18"

Area (ac)	CN	Description
* 3.620	61	grass
* 0.660	98	impervious
4.280	67	Weighted Average
3.620		84.58% Pervious Area
0.660		15.42% Impervious Area

Tc (min)	Length (feet)	Slope (ft/ft)	Velocity (ft/sec)	Capacity (cfs)	Description
10.0	100	0.0600	0.17		Sheet Flow, Grass: Dense n= 0.240 P2= 2.70"
0.6	150	0.0600	3.94		Shallow Concentrated Flow, Unpaved Kv= 16.1 fps
10.6	250	Total			

Subcatchment E3: Subarea

Hydrograph

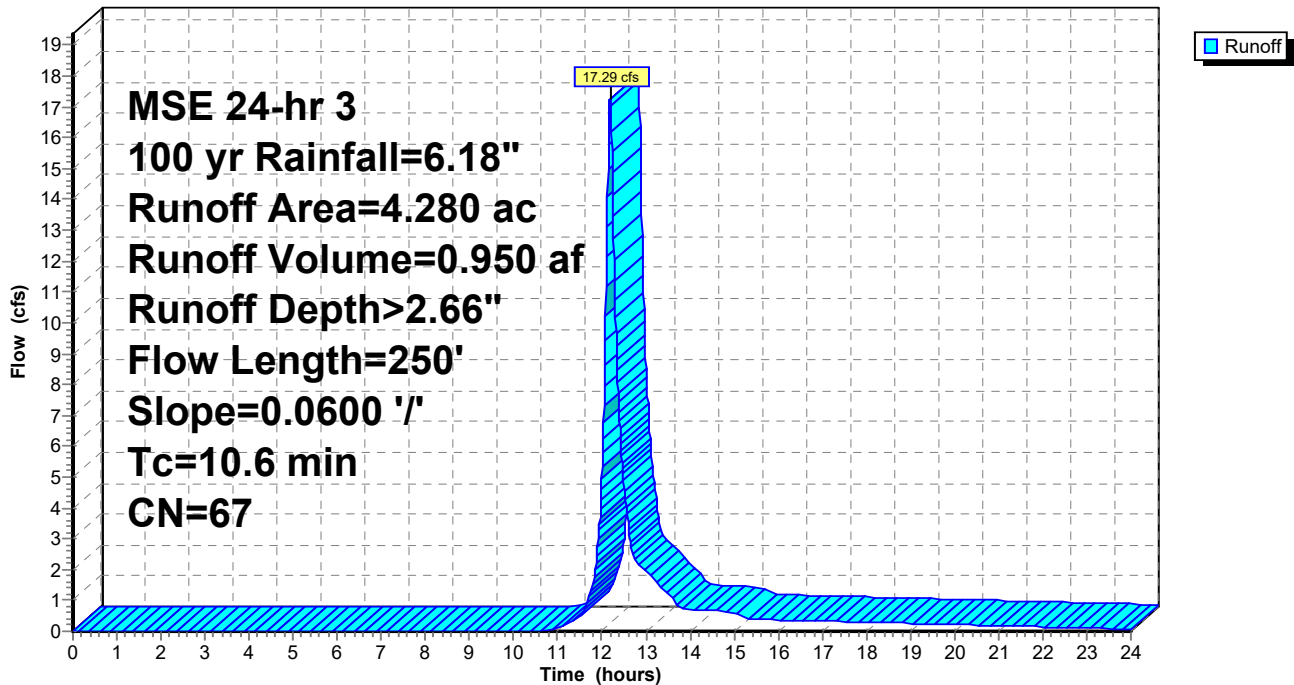

Proposed_2026-002

Prepared by Sound Stormwater Design

HydroCAD® 10.20-4c s/n 11025 © 2024 HydroCAD Software Solutions LLC

MSE 24-hr 3 100 yr Rainfall=6.18"

Printed 5/13/2026

Page 120

Summary for Subcatchment E4: Subarea

Runoff = 4.73 cfs @ 12.14 hrs, Volume= 0.211 af, Depth> 2.67"

Routed to Link 1L : Discharge to County Road I

Runoff by SCS TR-20 method, UH=SCS, Weighted-CN, Time Span= 0.00-24.00 hrs, dt= 0.01 hrs
MSE 24-hr 3 100 yr Rainfall=6.18"

Area (ac)	CN	Description
* 0.790	61	grass
* 0.050	98	impervious
* 0.110	98	impervious - offsite
0.950	67	Weighted Average
0.790		83.16% Pervious Area
0.160		16.84% Impervious Area

Tc (min)	Length (feet)	Slope (ft/ft)	Velocity (ft/sec)	Capacity (cfs)	Description
6.0					Direct Entry,

Subcatchment E4: Subarea

Hydrograph

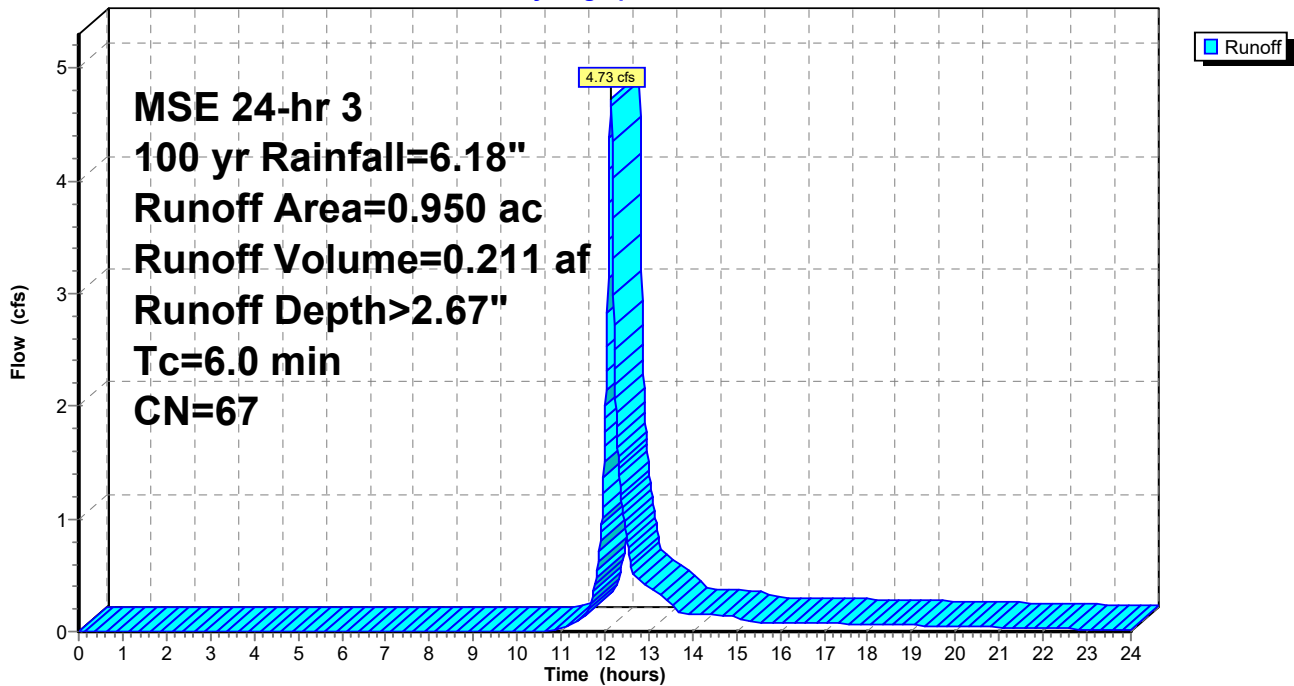

Proposed_2026-002

Prepared by Sound Stormwater Design

HydroCAD® 10.20-4c s/n 11025 © 2024 HydroCAD Software Solutions LLC

MSE 24-hr 3 100 yr Rainfall=6.18"

Printed 5/13/2026

Page 121

Summary for Subcatchment E5: Subarea

Runoff = 5.29 cfs @ 12.20 hrs, Volume= 0.305 af, Depth> 3.24"

Routed to Link 1L : Discharge to County Road I

Runoff by SCS TR-20 method, UH=SCS, Weighted-CN, Time Span= 0.00-24.00 hrs, dt= 0.01 hrs
MSE 24-hr 3 100 yr Rainfall=6.18"

Area (ac)	CN	Description
* 0.750	61	grass
* 0.380	98	impervious
1.130	73	Weighted Average
0.750		66.37% Pervious Area
0.380		33.63% Impervious Area

Tc (min)	Length (feet)	Slope (ft/ft)	Velocity (ft/sec)	Capacity (cfs)	Description
11.8	100	0.0400	0.14		Sheet Flow, Grass: Dense n= 0.240 P2= 2.70"

Subcatchment E5: Subarea

Hydrograph

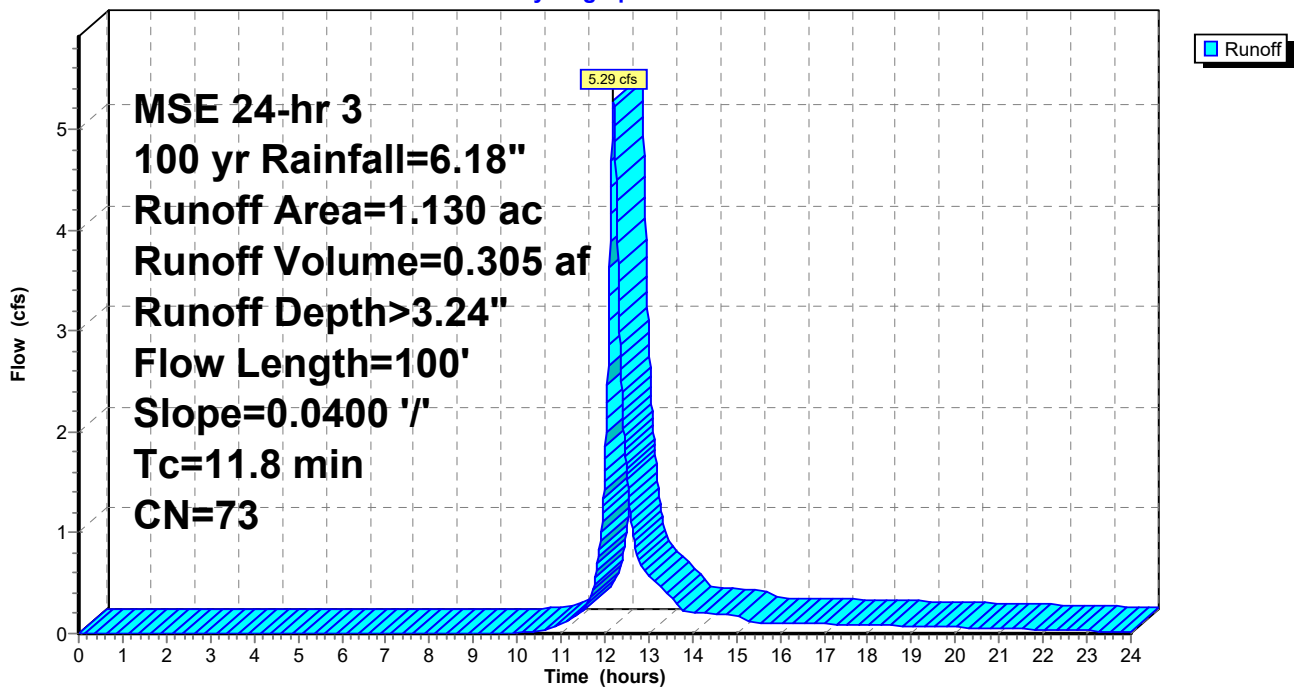

Proposed_2026-002

Prepared by Sound Stormwater Design

HydroCAD® 10.20-4c s/n 11025 © 2024 HydroCAD Software Solutions LLC

MSE 24-hr 3 100 yr Rainfall=6.18"

Printed 5/13/2026

Page 122

Summary for Subcatchment N1: Subarea

Runoff = 54.65 cfs @ 12.29 hrs, Volume= 3.945 af, Depth> 2.66"
 Routed to Pond 1D : Depression

Runoff by SCS TR-20 method, UH=SCS, Weighted-CN, Time Span= 0.00-24.00 hrs, dt= 0.01 hrs
 MSE 24-hr 3 100 yr Rainfall=6.18"

Area (ac)	CN	Description
* 10.590	69	cropland
* 6.590	61	grass
* 0.600	98	impervious - offsite
17.780	67	Weighted Average
17.180		96.63% Pervious Area
0.600		3.37% Impervious Area

Tc (min)	Length (feet)	Slope (ft/ft)	Velocity (ft/sec)	Capacity (cfs)	Description
7.1	100	0.0700	0.23		Sheet Flow, Cultivated: Residue>20% n= 0.170 P2= 2.70"
3.9	555	0.0700	2.38		Shallow Concentrated Flow, Cultivated Straight Rows Kv= 9.0 fps
7.6	410	0.0100	0.90		Shallow Concentrated Flow, Cultivated Straight Rows Kv= 9.0 fps
18.6	1,065	Total			

Subcatchment N1: Subarea

Hydrograph

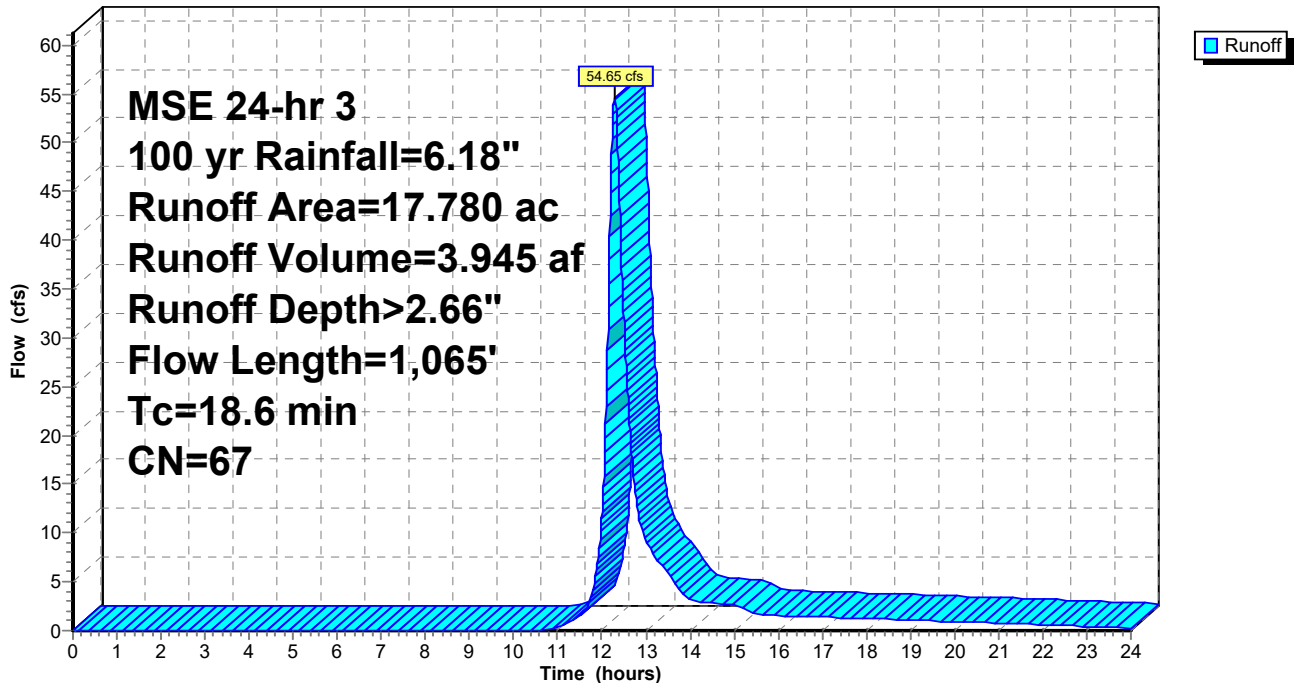

Proposed_2026-002

Prepared by Sound Stormwater Design

HydroCAD® 10.20-4c s/n 11025 © 2024 HydroCAD Software Solutions LLC

MSE 24-hr 3 100 yr Rainfall=6.18"

Printed 5/13/2026

Page 123

Summary for Subcatchment N2: Subarea

Runoff = 33.31 cfs @ 12.17 hrs, Volume= 1.731 af, Depth> 2.95"

Routed to Pond 2D : Depression

Runoff by SCS TR-20 method, UH=SCS, Weighted-CN, Time Span= 0.00-24.00 hrs, dt= 0.01 hrs
MSE 24-hr 3 100 yr Rainfall=6.18"

Area (ac)	CN	Description
* 5.220	69	cropland
* 1.330	61	grass
* 0.500	98	impervious - offsite
7.050	70	Weighted Average
6.550		92.91% Pervious Area
0.500		7.09% Impervious Area

Tc (min)	Length (feet)	Slope (ft/ft)	Velocity (ft/sec)	Capacity (cfs)	Description
7.1	100	0.0700	0.23		Sheet Flow, Cultivated: Residue>20% n= 0.170 P2= 2.70"
2.2	320	0.0700	2.38		Shallow Concentrated Flow, Cultivated Straight Rows Kv= 9.0 fps
9.3	420	Total			

Subcatchment N2: Subarea

Hydrograph

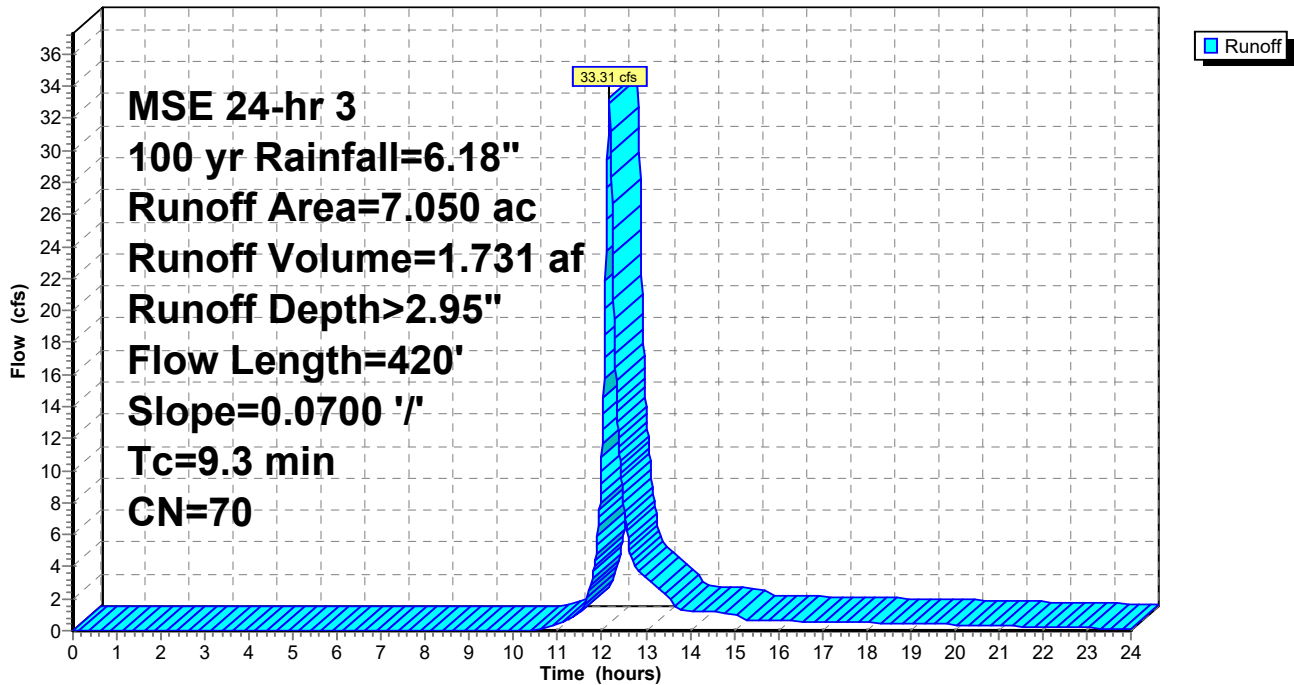

Proposed_2026-002

Prepared by Sound Stormwater Design

HydroCAD® 10.20-4c s/n 11025 © 2024 HydroCAD Software Solutions LLC

MSE 24-hr 3 100 yr Rainfall=6.18"

Printed 5/13/2026

Page 124

Summary for Subcatchment N3: Subarea

Runoff = 74.17 cfs @ 12.41 hrs, Volume= 6.600 af, Depth> 2.94"

Routed to Pond 3D : Depression

Runoff by SCS TR-20 method, UH=SCS, Weighted-CN, Time Span= 0.00-24.00 hrs, dt= 0.01 hrs
 MSE 24-hr 3 100 yr Rainfall=6.18"

Area (ac)	CN	Description
* 24.440	69	cropland
* 1.360	61	grass
* 1.120	98	impervious - offsite
26.920	70	Weighted Average
25.800		95.84% Pervious Area
1.120		4.16% Impervious Area

Tc (min)	Length (feet)	Slope (ft/ft)	Velocity (ft/sec)	Capacity (cfs)	Description
11.8	100	0.0400	0.14		Sheet Flow, Grass: Dense n= 0.240 P2= 2.70"
15.8	1,710	0.0400	1.80		Shallow Concentrated Flow, Cultivated Straight Rows Kv= 9.0 fps
27.6	1,810	Total			

Subcatchment N3: Subarea

Hydrograph

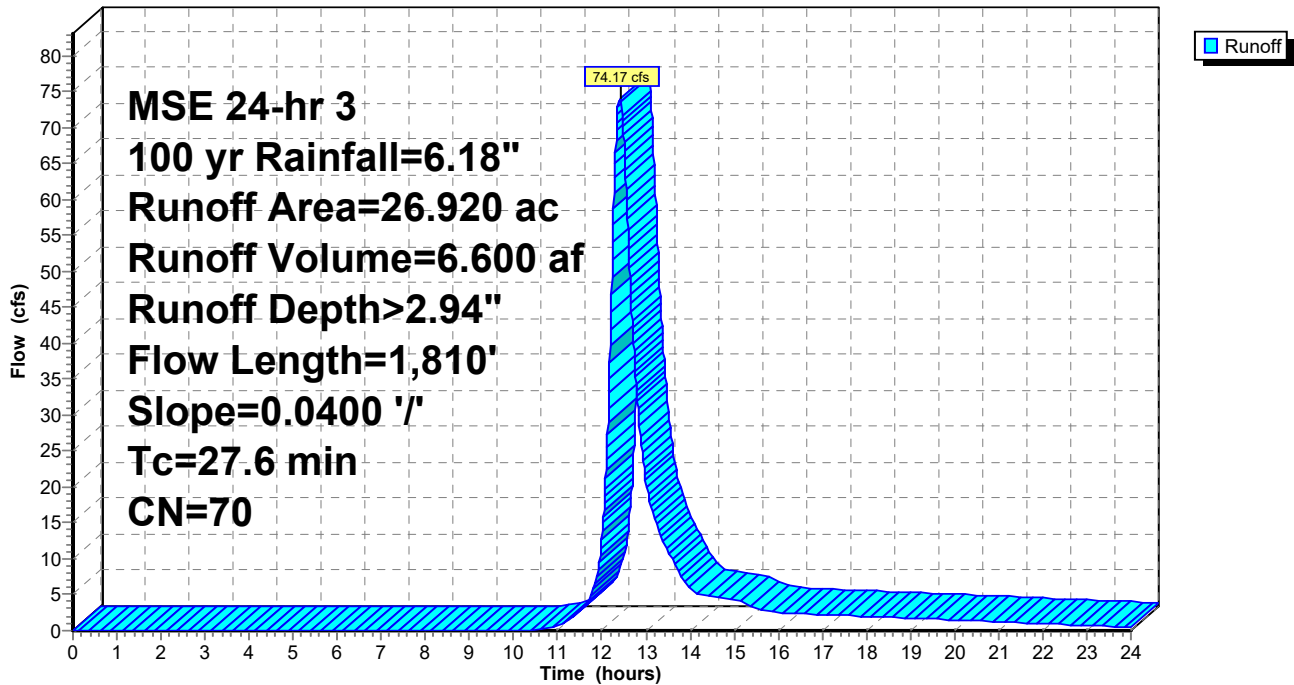

Proposed_2026-002

Prepared by Sound Stormwater Design

HydroCAD® 10.20-4c s/n 11025 © 2024 HydroCAD Software Solutions LLC

MSE 24-hr 3 100 yr Rainfall=6.18"

Printed 5/13/2026

Page 125

Summary for Subcatchment N4: Subarea

Runoff = 71.35 cfs @ 12.19 hrs, Volume= 3.969 af, Depth> 2.30"
 Routed to Pond 4K : Kettle

Runoff by SCS TR-20 method, UH=SCS, Weighted-CN, Time Span= 0.00-24.00 hrs, dt= 0.01 hrs
 MSE 24-hr 3 100 yr Rainfall=6.18"

Area (ac)	CN	Description
* 19.790	61	grass
* 0.100	98	impervious
* 0.810	98	impervious - offsite
20.700	63	Weighted Average
19.790		95.60% Pervious Area
0.910		4.40% Impervious Area

Tc (min)	Length (feet)	Slope (ft/ft)	Velocity (ft/sec)	Capacity (cfs)	Description
10.0	100	0.0600	0.17		Sheet Flow, Grass: Dense n= 0.240 P2= 2.70"
0.7	160	0.0600	3.94		Shallow Concentrated Flow, Unpaved Kv= 16.1 fps
10.7	260	Total			

Subcatchment N4: Subarea

Hydrograph

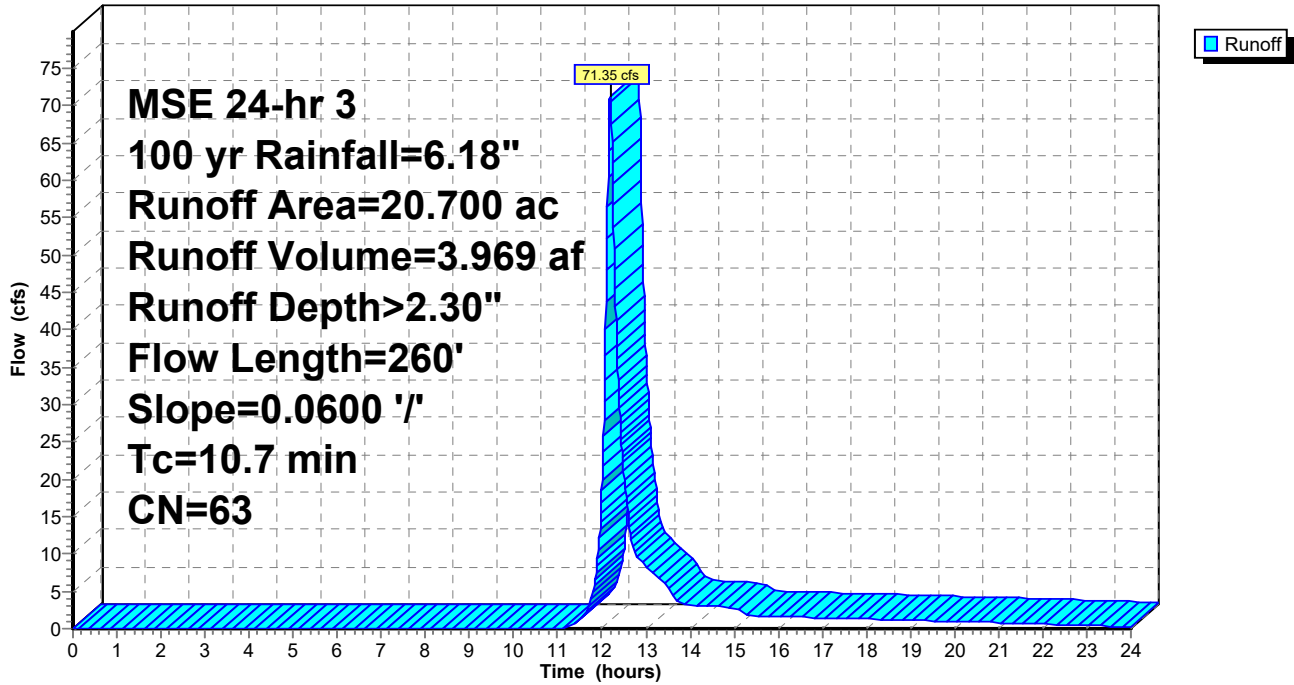

Proposed_2026-002

Prepared by Sound Stormwater Design

HydroCAD® 10.20-4c s/n 11025 © 2024 HydroCAD Software Solutions LLC

MSE 24-hr 3 100 yr Rainfall=6.18"

Printed 5/13/2026

Page 126

Summary for Subcatchment S1: Subarea

Runoff = 36.34 cfs @ 12.24 hrs, Volume= 2.344 af, Depth> 2.48"
Routed to Pond 9B : Basin

Runoff by SCS TR-20 method, UH=SCS, Weighted-CN, Time Span= 0.00-24.00 hrs, dt= 0.01 hrs
MSE 24-hr 3 100 yr Rainfall=6.18"

Area (ac)	CN	Description
* 10.020	61	grass
* 1.320	98	impervious
11.340	65	Weighted Average
10.020		88.36% Pervious Area
1.320		11.64% Impervious Area

Tc (min)	Length (feet)	Slope (ft/ft)	Velocity (ft/sec)	Capacity (cfs)	Description
10.0	100	0.0600	0.17		Sheet Flow, Grass: Dense n= 0.240 P2= 2.70"
1.0	245	0.0600	3.94		Shallow Concentrated Flow, Unpaved Kv= 16.1 fps
3.8	485	0.0200	2.12		Shallow Concentrated Flow, Grassed Waterway Kv= 15.0 fps
14.8	830	Total			

Subcatchment S1: Subarea

Hydrograph

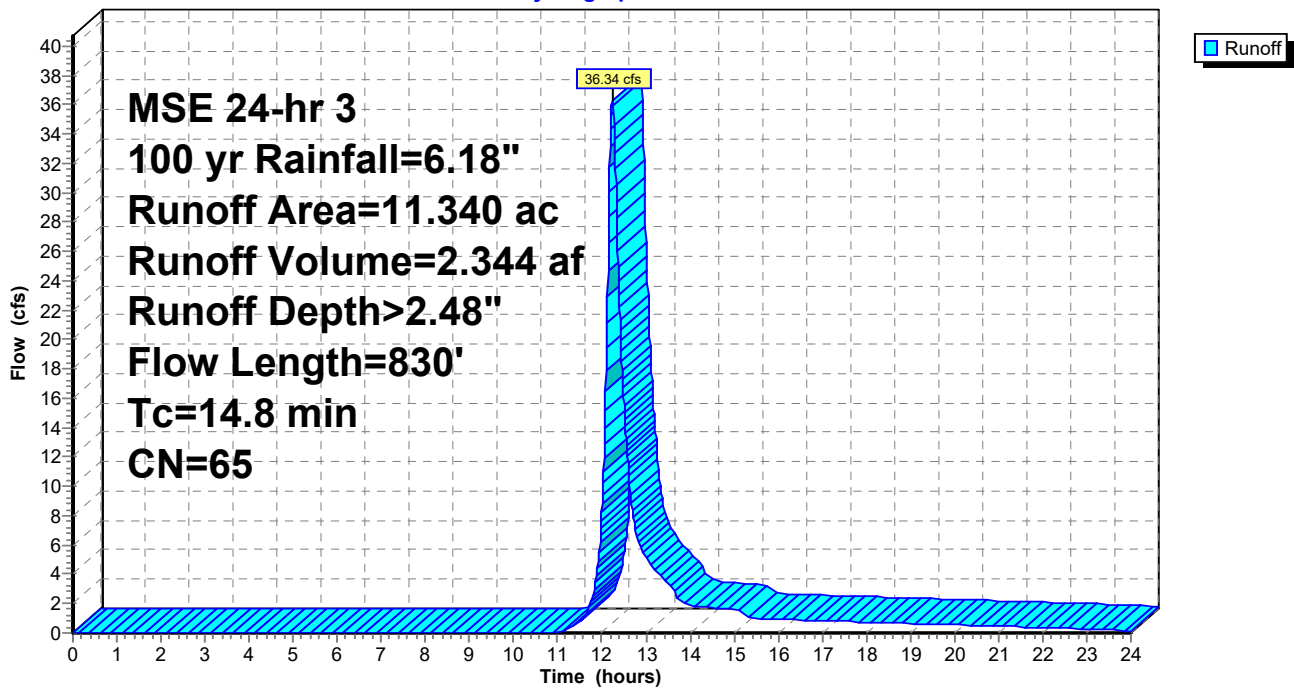

Proposed_2026-002

Prepared by Sound Stormwater Design

HydroCAD® 10.20-4c s/n 11025 © 2024 HydroCAD Software Solutions LLC

MSE 24-hr 3 100 yr Rainfall=6.18"

Printed 5/13/2026

Page 127

Summary for Subcatchment S2: Subarea

Runoff = 9.93 cfs @ 12.24 hrs, Volume= 0.640 af, Depth> 2.21"
 Routed to Pond 10B : Basin

Runoff by SCS TR-20 method, UH=SCS, Weighted-CN, Time Span= 0.00-24.00 hrs, dt= 0.01 hrs
 MSE 24-hr 3 100 yr Rainfall=6.18"

Area (ac)	CN	Description
* 3.420	61	grass
* 0.050	98	impervious
3.470	62	Weighted Average
3.420		98.56% Pervious Area
0.050		1.44% Impervious Area

Tc (min)	Length (feet)	Slope (ft/ft)	Velocity (ft/sec)	Capacity (cfs)	Description
13.2	100	0.0300	0.13		Sheet Flow, Grass: Dense n= 0.240 P2= 2.70"
0.5	90	0.0300	2.79		Shallow Concentrated Flow, Unpaved Kv= 16.1 fps
0.6	150	0.0700	3.97		Shallow Concentrated Flow, Grassed Waterway Kv= 15.0 fps
14.3	340	Total			

Subcatchment S2: Subarea

Hydrograph

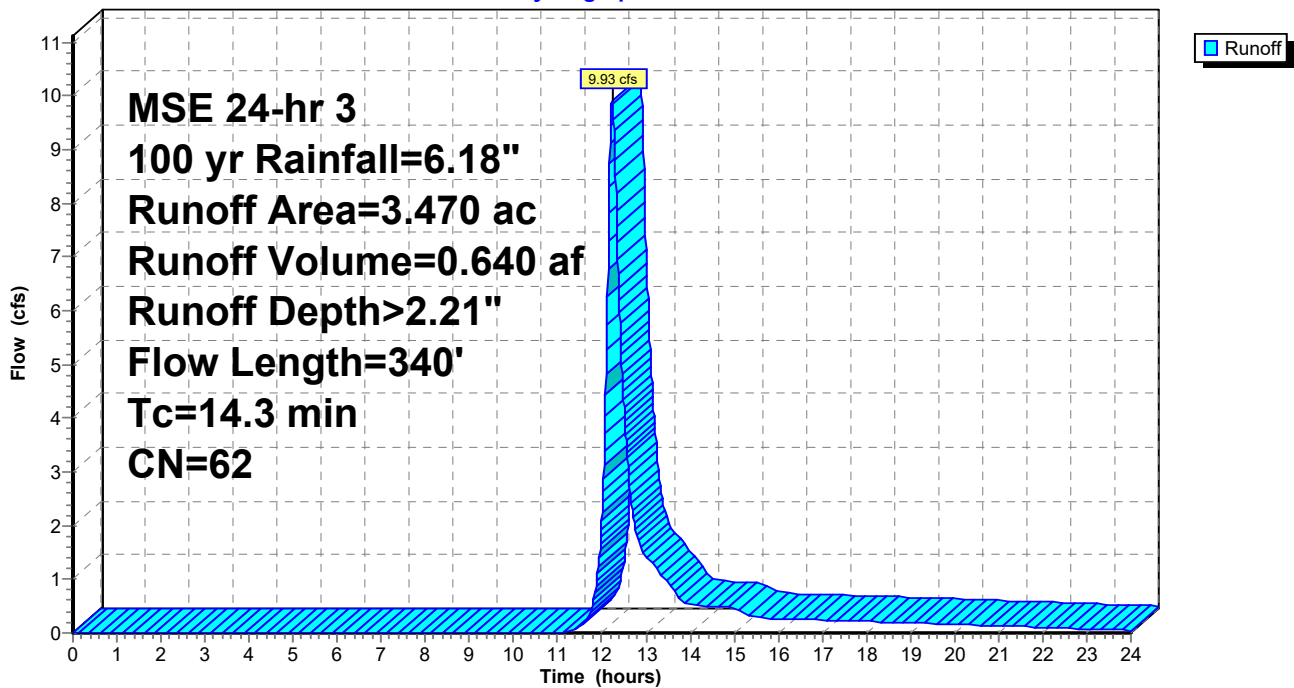

Proposed_2026-002

Prepared by Sound Stormwater Design

HydroCAD® 10.20-4c s/n 11025 © 2024 HydroCAD Software Solutions LLC

MSE 24-hr 3 100 yr Rainfall=6.18"

Printed 5/13/2026

Page 128

Summary for Subcatchment S3: Subarea

Runoff = 7.91 cfs @ 12.17 hrs, Volume= 0.403 af, Depth> 2.48"

Routed to Link 2L : Discharge South

Runoff by SCS TR-20 method, UH=SCS, Weighted-CN, Time Span= 0.00-24.00 hrs, dt= 0.01 hrs
MSE 24-hr 3 100 yr Rainfall=6.18"

Area (ac)	CN	Description
* 1.740	61	grass
* 0.210	98	impervious
1.950	65	Weighted Average
1.740		89.23% Pervious Area
0.210		10.77% Impervious Area

Tc (min)	Length (feet)	Slope (ft/ft)	Velocity (ft/sec)	Capacity (cfs)	Description
8.5	100	0.0900	0.20		Sheet Flow, Grass: Dense n= 0.240 P2= 2.70"
0.3	100	0.0900	4.83		Shallow Concentrated Flow, Unpaved Kv= 16.1 fps
8.8	200	Total			

Subcatchment S3: Subarea

Hydrograph

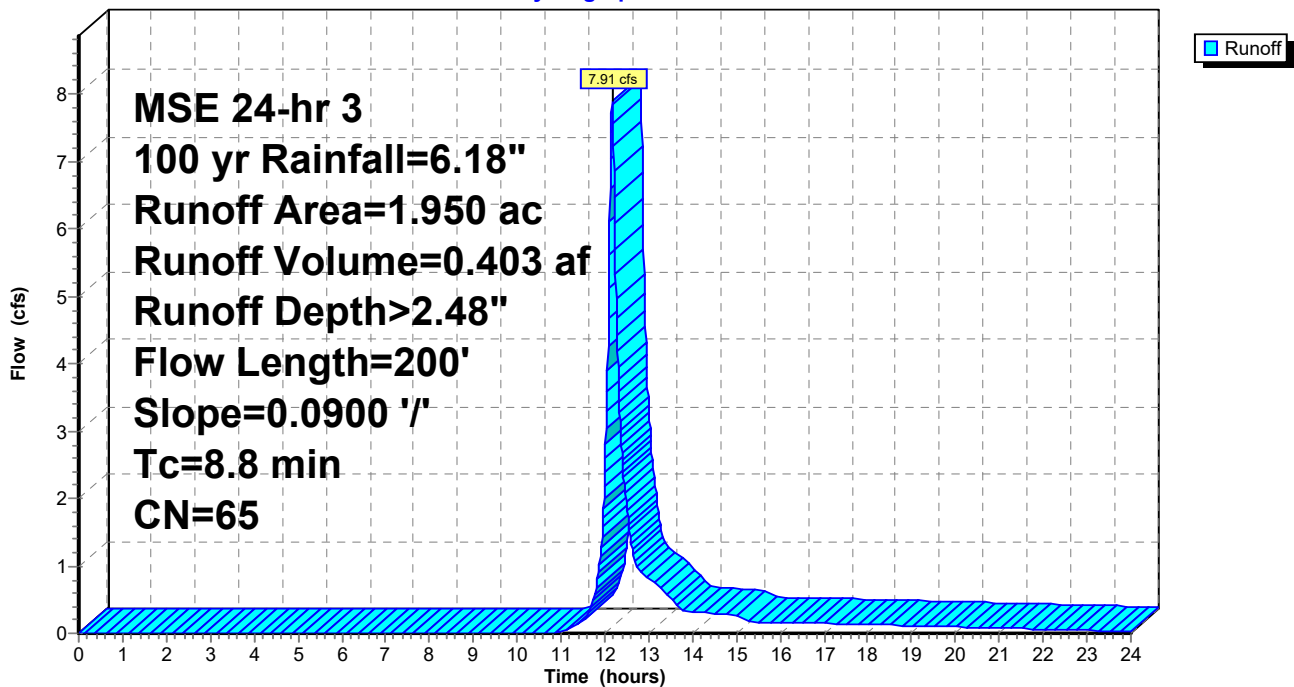

Proposed_2026-002

Prepared by Sound Stormwater Design

HydroCAD® 10.20-4c s/n 11025 © 2024 HydroCAD Software Solutions LLC

MSE 24-hr 3 100 yr Rainfall=6.18"

Printed 5/13/2026

Page 129

Summary for Subcatchment W1: Subarea

Runoff = 22.07 cfs @ 12.18 hrs, Volume= 1.188 af, Depth> 2.21"

Routed to Pond 5D : Depression

Runoff by SCS TR-20 method, UH=SCS, Weighted-CN, Time Span= 0.00-24.00 hrs, dt= 0.01 hrs
MSE 24-hr 3 100 yr Rainfall=6.18"

Area (ac)	CN	Description
* 6.320	61	grass
* 0.080	98	impervious
* 0.040	98	impervious - offsite
6.440	62	Weighted Average
6.320		98.14% Pervious Area
0.120		1.86% Impervious Area

Tc (min)	Length (feet)	Slope (ft/ft)	Velocity (ft/sec)	Capacity (cfs)	Description
8.5	100	0.0900	0.20		Sheet Flow, Grass: Dense n= 0.240 P2= 2.70"
1.4	400	0.0900	4.83		Shallow Concentrated Flow, Unpaved Kv= 16.1 fps
9.9	500	Total			

Subcatchment W1: Subarea

Hydrograph

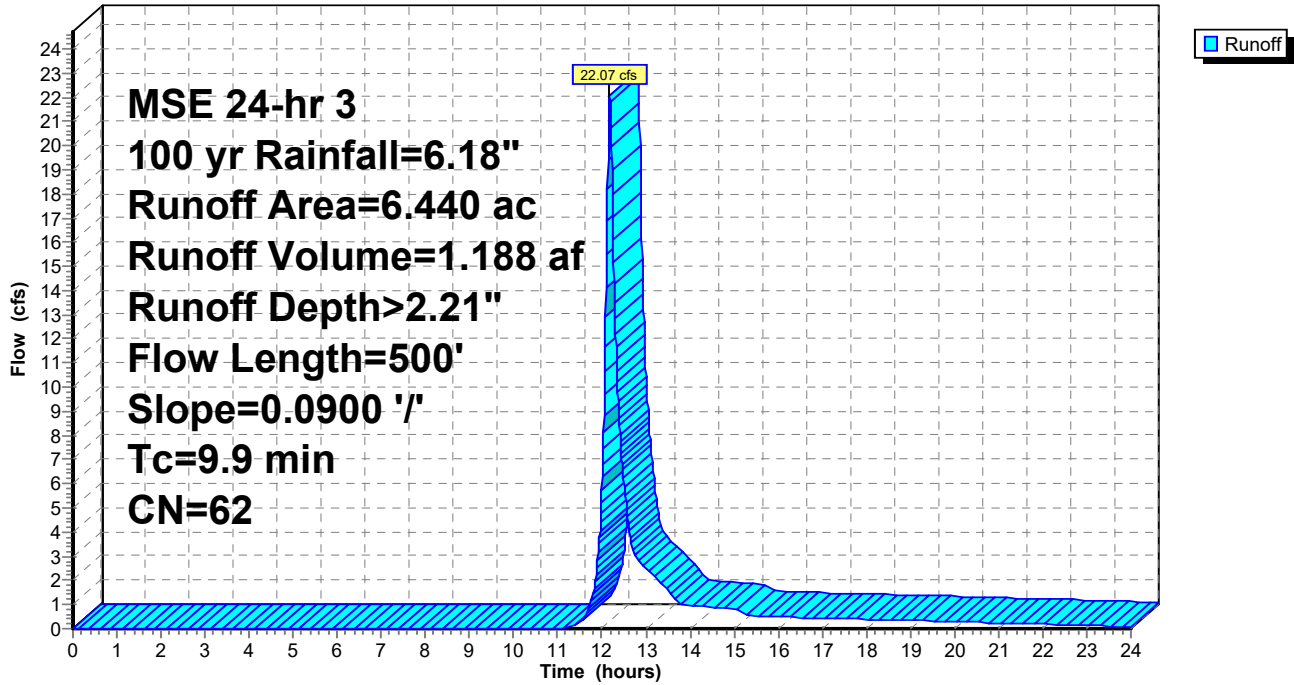

Summary for Pond 1D: Depression

Inflow Area = 17.780 ac, 3.37% Impervious, Inflow Depth > 2.66" for 100 yr event
 Inflow = 54.65 cfs @ 12.29 hrs, Volume= 3.945 af
 Outflow = 35.74 cfs @ 12.47 hrs, Volume= 3.686 af, Atten= 35%, Lag= 10.7 min
 Discarded = 0.74 cfs @ 12.47 hrs, Volume= 0.252 af
 Primary = 35.00 cfs @ 12.47 hrs, Volume= 3.433 af
 Routed to Pond 2D : Depression

Routing by Sim-Route method, Time Span= 0.00-24.00 hrs, dt= 0.01 hrs
 Peak Elev= 975.91' @ 12.47 hrs Surf.Area= 1.377 ac Storage= 0.968 af

Plug-Flow detention time= 53.1 min calculated for 3.684 af (93% of inflow)
 Center-of-Mass det. time= 22.1 min (847.9 - 825.8)

Volume	Invert	Avail.Storage	Storage Description		
#1	973.00'	1.097 af	Custom Stage Data (Conic) Listed below (Recalc)		
Elevation (feet)	Surf.Area (acres)	Inc.Store (acre-feet)	Cum.Store (acre-feet)	Wet.Area (acres)	
973.00	0.050	0.000	0.000	0.050	
974.00	0.080	0.064	0.064	0.080	
975.00	0.320	0.187	0.251	0.320	
976.00	1.520	0.846	1.097	1.521	

Device	Routing	Invert	Outlet Devices									
#1	Discarded	973.00'	0.500 in/hr Exfiltration over Surface area Conductivity to Groundwater Elevation = 963.00' Phase-In= 0.01'									
#2	Primary	975.00'	15.0' long x 10.0' breadth Broad-Crested Rectangular Weir Head (feet) 0.20 0.40 0.60 0.80 1.00 1.20 1.40 1.60 Coef. (English) 2.49 2.56 2.70 2.69 2.68 2.69 2.67 2.64									

Discarded OutFlow Max=0.74 cfs @ 12.47 hrs HW=975.91' (Free Discharge)
 ↑1=Exfiltration (Controls 0.74 cfs)

Primary OutFlow Max=35.00 cfs @ 12.47 hrs HW=975.91' TW=972.94' (Dynamic Tailwater)
 ↑2=Broad-Crested Rectangular Weir(Weir Controls 35.00 cfs @ 2.56 fps)

Pond 1D: Depression

Hydrograph

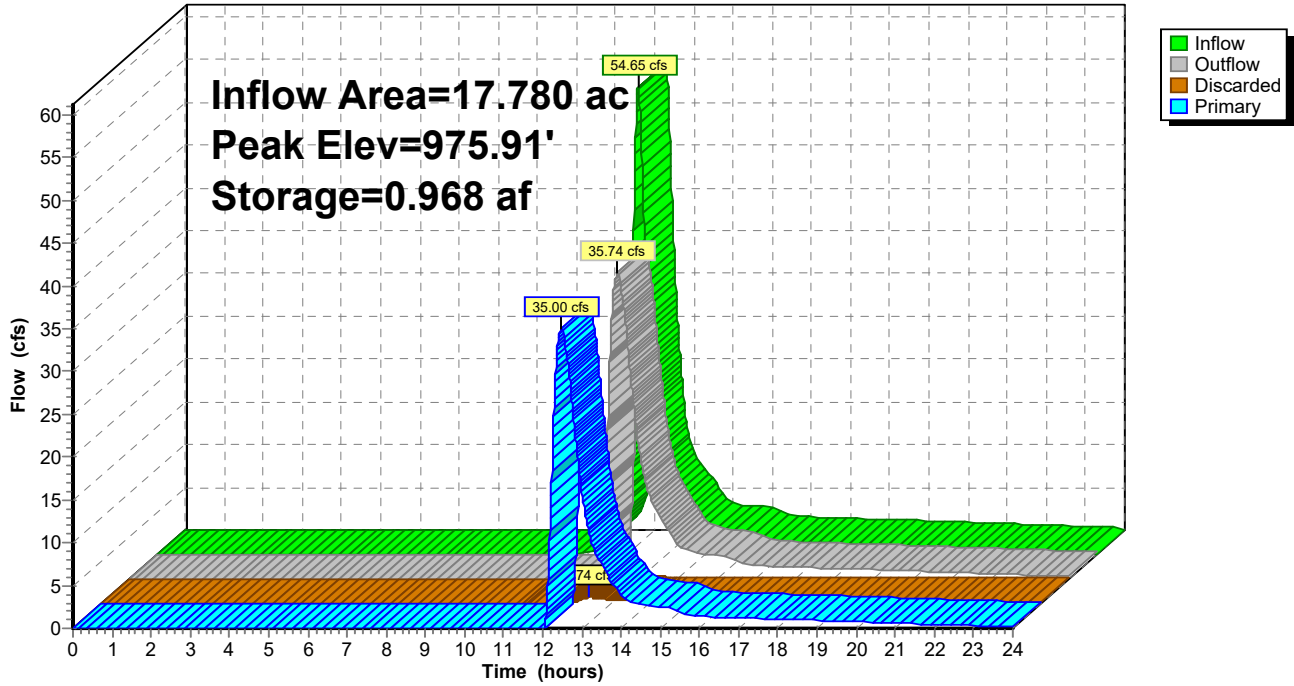

Proposed_2026-002

MSE 24-hr 3 100 yr Rainfall=6.18"

Prepared by Sound Stormwater Design

Printed 5/13/2026

HydroCAD® 10.20-4c s/n 11025 © 2024 HydroCAD Software Solutions LLC

Page 132

Summary for Pond 2D: Depression

Inflow Area = 24.830 ac, 4.43% Impervious, Inflow Depth > 2.50" for 100 yr event
 Inflow = 45.43 cfs @ 12.21 hrs, Volume= 5.165 af
 Outflow = 28.27 cfs @ 12.79 hrs, Volume= 5.109 af, Atten= 38%, Lag= 35.2 min
 Discarded = 0.58 cfs @ 12.79 hrs, Volume= 0.316 af
 Primary = 27.68 cfs @ 12.79 hrs, Volume= 4.793 af
 Routed to Pond 3D : Depression

Routing by Sim-Route method, Time Span= 0.00-24.00 hrs, dt= 0.01 hrs
 Peak Elev= 973.64' @ 12.79 hrs Surf.Area= 0.969 ac Storage= 2.017 af

Plug-Flow detention time= 106.0 min calculated for 5.107 af (99% of inflow)
 Center-of-Mass det. time= 100.0 min (927.8 - 827.9)

Volume	Invert	Avail.Storage	Storage Description		
#1	970.00'	2.382 af	Custom Stage Data (Conic) Listed below (Recalc)		
Elevation (feet)	Surf.Area (acres)	Inc.Store (acre-feet)	Cum.Store (acre-feet)	Wet.Area (acres)	
970.00	0.120	0.000	0.000	0.120	
971.00	0.400	0.246	0.246	0.400	
972.00	0.610	0.501	0.748	0.610	
973.00	0.800	0.703	1.451	0.801	
974.00	1.070	0.932	2.382	1.071	

Device	Routing	Invert	Outlet Devices
#1	Discarded	970.00'	0.500 in/hr Exfiltration over Surface area Conductivity to Groundwater Elevation = 960.00' Phase-In= 0.01'
#2	Primary	970.00'	15.0" Round Culvert L= 40.0' CMP, end-section conforming to fill, Ke= 0.500 Inlet / Outlet Invert= 970.00' / 969.50' S= 0.0125 '/' Cc= 0.900 n= 0.024, Flow Area= 1.23 sf
#3	Primary	973.50'	150.0' long x 10.0' breadth Broad-Crested Rectangular Weir Head (feet) 0.20 0.40 0.60 0.80 1.00 1.20 1.40 1.60 Coef. (English) 2.49 2.56 2.70 2.69 2.68 2.69 2.67 2.64

Discarded OutFlow Max=0.58 cfs @ 12.79 hrs HW=973.64' (Free Discharge)
 ↑1=Exfiltration (Controls 0.58 cfs)

Primary OutFlow Max=27.67 cfs @ 12.79 hrs HW=973.64' TW=953.24' (Dynamic Tailwater)
 ↑2=Culvert (Barrel Controls 7.74 cfs @ 6.31 fps)
 ↑3=Broad-Crested Rectangular Weir(Weir Controls 19.93 cfs @ 0.94 fps)

Pond 2D: Depression

Hydrograph

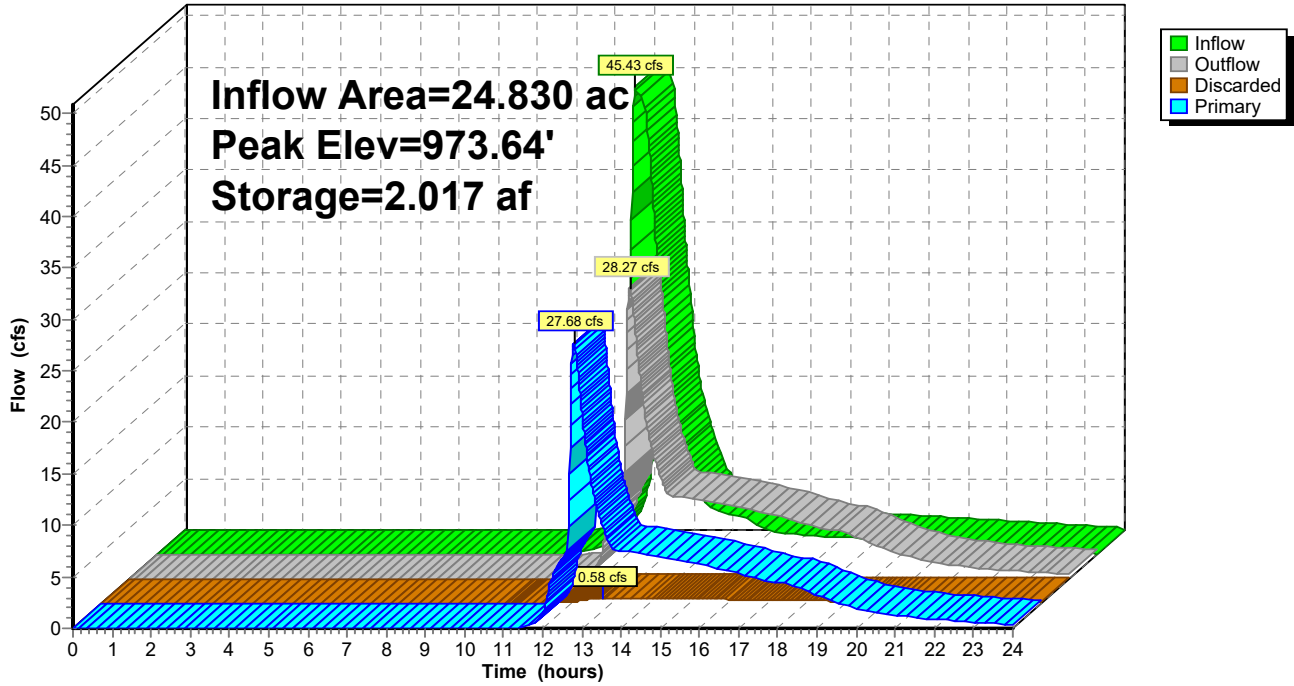

Summary for Pond 3D: Depression

[86] Warning: Oscillations may require smaller dt (severity=50)

Inflow Area = 51.750 ac, 4.29% Impervious, Inflow Depth > 2.64" for 100 yr event
 Inflow = 80.62 cfs @ 12.42 hrs, Volume= 11.393 af
 Outflow = 80.59 cfs @ 12.43 hrs, Volume= 11.389 af, Atten= 0%, Lag= 0.6 min
 Discarded = 0.09 cfs @ 12.43 hrs, Volume= 0.048 af
 Primary = 80.51 cfs @ 12.43 hrs, Volume= 11.341 af
 Routed to Pond 4K : Kettle

Routing by Sim-Route method, Time Span= 0.00-24.00 hrs, dt= 0.01 hrs
 Peak Elev= 953.36' @ 12.43 hrs Surf.Area= 0.161 ac Storage= 0.110 af

Plug-Flow detention time= (not calculated: outflow precedes inflow)
 Center-of-Mass det. time= 0.7 min (869.9 - 869.2)

Volume	Invert	Avail.Storage	Storage Description		
#1	950.40'	0.563 af	Custom Stage Data (Conic) Listed below (Recalc)		
Elevation (feet)	Surf.Area (acres)	Inc.Store (acre-feet)	Cum.Store (acre-feet)	Wet.Area (acres)	
950.40	0.000	0.000	0.000	0.000	
952.00	0.010	0.005	0.005	0.010	
953.00	0.120	0.055	0.060	0.120	
954.00	0.250	0.181	0.241	0.250	
955.00	0.400	0.322	0.563	0.401	

Device	Routing	Invert	Outlet Devices
#1	Discarded	950.40'	0.500 in/hr Exfiltration over Surface area Conductivity to Groundwater Elevation = 940.00' Phase-In= 0.01'
#2	Primary	950.40'	15.0" Round Culvert L= 30.0' CMP, end-section conforming to fill, Ke= 0.500 Inlet / Outlet Invert= 950.40' / 948.95' S= 0.0483 '/' Cc= 0.900 n= 0.024, Flow Area= 1.23 sf
#3	Primary	952.70'	50.0' long x 10.0' breadth Broad-Crested Rectangular Weir Head (feet) 0.20 0.40 0.60 0.80 1.00 1.20 1.40 1.60 Coef. (English) 2.49 2.56 2.70 2.69 2.68 2.69 2.67 2.64

Discarded OutFlow Max=0.09 cfs @ 12.43 hrs HW=953.36' (Free Discharge)
 ↑1=Exfiltration (Controls 0.09 cfs)

Primary OutFlow Max=80.46 cfs @ 12.43 hrs HW=953.36' TW=948.73' (Dynamic Tailwater)
 ↑2=Culvert (Barrel Controls 8.88 cfs @ 7.23 fps)
 ↑3=Broad-Crested Rectangular Weir(Weir Controls 71.58 cfs @ 2.18 fps)

Pond 3D: Depression

Hydrograph

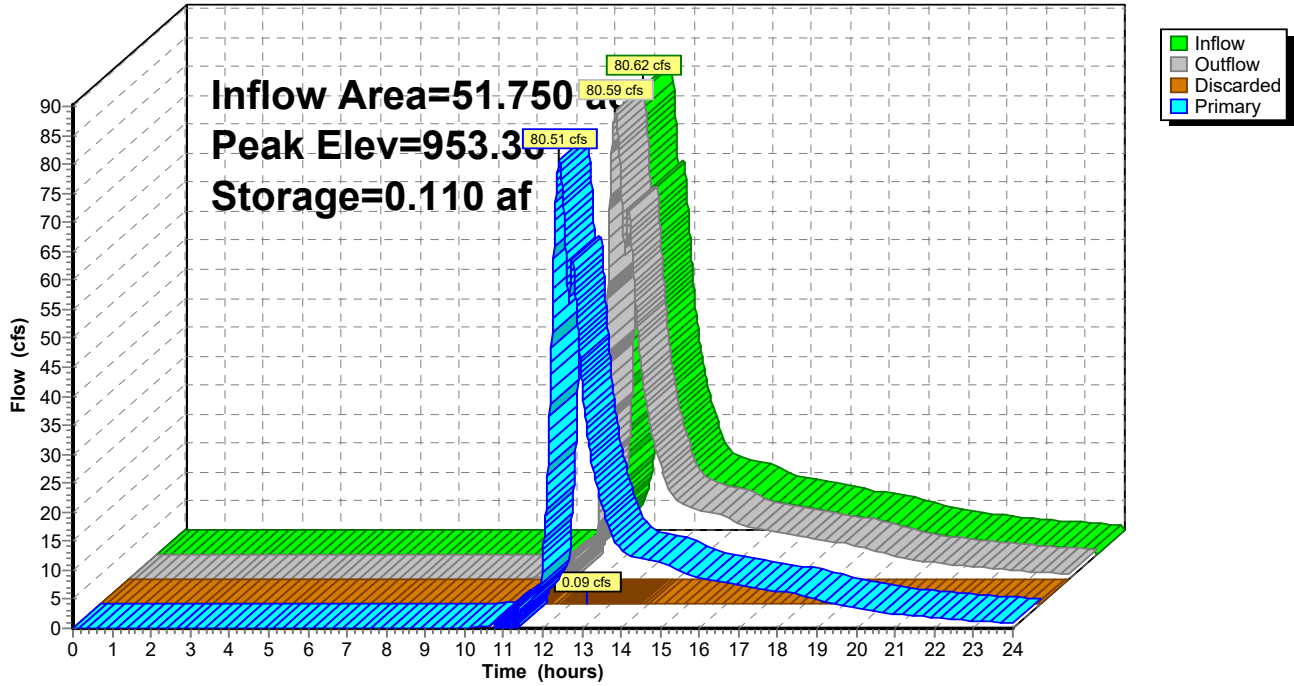

Proposed_2026-002

MSE 24-hr 3 100 yr Rainfall=6.18"

Prepared by Sound Stormwater Design

Printed 5/13/2026

HydroCAD® 10.20-4c s/n 11025 © 2024 HydroCAD Software Solutions LLC

Page 136

Summary for Pond 4K: Kettle

Inflow Area = 78.890 ac, 4.12% Impervious, Inflow Depth > 2.38" for 100 yr event
 Inflow = 116.12 cfs @ 12.23 hrs, Volume= 15.646 af
 Outflow = 2.40 cfs @ 22.06 hrs, Volume= 2.111 af, Atten= 98%, Lag= 589.5 min
 Discarded = 2.40 cfs @ 22.06 hrs, Volume= 2.111 af

Routing by Sim-Route method, Time Span= 0.00-24.00 hrs, dt= 0.01 hrs
 Peak Elev= 952.70' @ 22.06 hrs Surf.Area= 3.642 ac Storage= 13.641 af

Plug-Flow detention time= 387.8 min calculated for 2.111 af (13% of inflow)
 Center-of-Mass det. time= 251.2 min (1,109.2 - 858.0)

Volume	Invert	Avail.Storage	Storage Description
#1	944.80'	24.910 af	Custom Stage Data (Conic) Listed below (Recalc)

Elevation (feet)	Surf.Area (acres)	Inc.Store (acre-feet)	Cum.Store (acre-feet)	Wet.Area (acres)
944.80	0.000	0.000	0.000	0.000
945.00	0.140	0.009	0.009	0.140
946.00	0.720	0.392	0.402	0.720
947.00	1.120	0.913	1.314	1.120
948.00	1.460	1.286	2.601	1.461
949.00	1.790	1.622	4.223	1.792
950.00	2.130	1.958	6.180	2.133
951.00	2.520	2.322	8.503	2.523
952.00	3.080	2.795	11.298	3.084
953.00	3.900	3.482	14.780	3.905
954.00	5.360	4.611	19.391	5.365
955.00	5.680	5.519	24.910	5.688

Device	Routing	Invert	Outlet Devices
#1	Discarded	944.80'	0.500 in/hr Exfiltration over Surface area Conductivity to Groundwater Elevation = 935.00' Phase-In= 0.01'

Discarded OutFlow Max=2.40 cfs @ 22.06 hrs HW=952.70' (Free Discharge)

↑1=Exfiltration (Controls 2.40 cfs)

Pond 4K: Kettle

Hydrograph

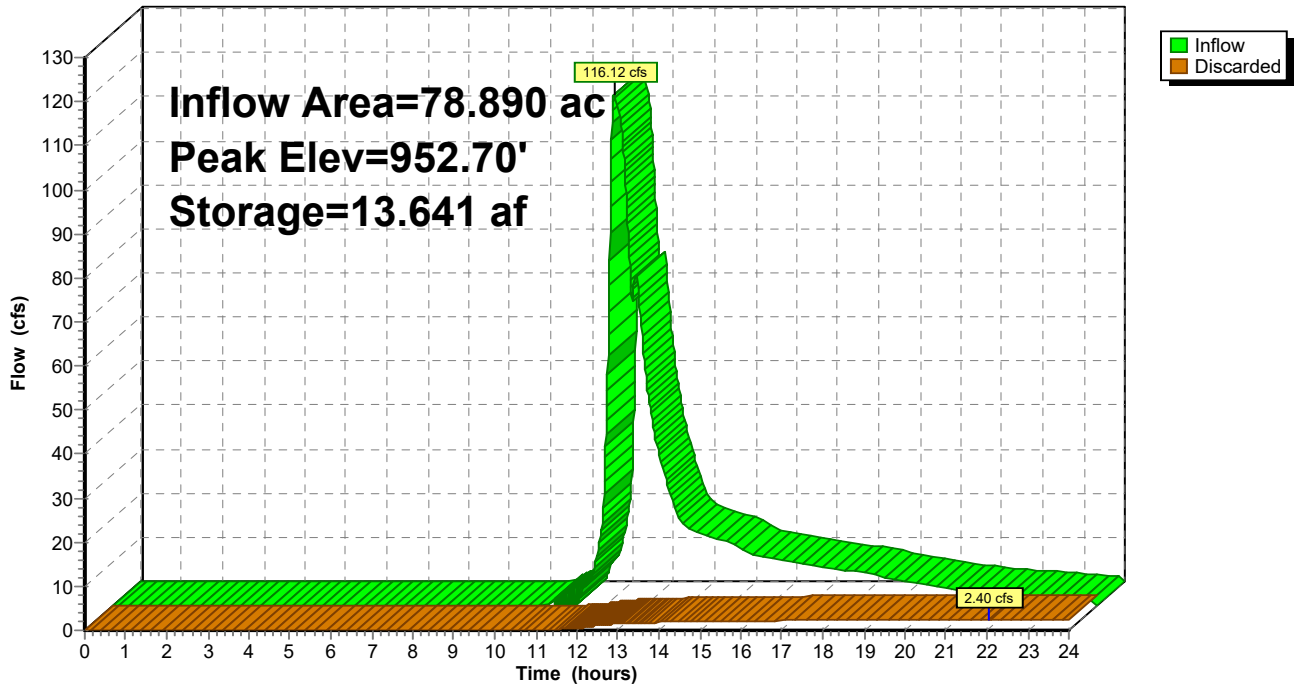

Summary for Pond 5D: Depression

Inflow Area = 6.440 ac, 1.86% Impervious, Inflow Depth > 2.21" for 100 yr event
 Inflow = 22.07 cfs @ 12.18 hrs, Volume= 1.187 af
 Outflow = 2.15 cfs @ 13.22 hrs, Volume= 0.673 af, Atten= 90%, Lag= 62.5 min
 Discarded = 0.37 cfs @ 13.22 hrs, Volume= 0.337 af
 Primary = 1.78 cfs @ 13.22 hrs, Volume= 0.336 af
 Routed to Pond 4K : Kettle

Routing by Sim-Route method, Time Span= 0.00-24.00 hrs, dt= 0.01 hrs
 Peak Elev= 954.17' @ 13.22 hrs Surf.Area= 0.670 ac Storage= 0.665 af

Plug-Flow detention time= 234.4 min calculated for 0.673 af (57% of inflow)
 Center-of-Mass det. time= 141.6 min (968.5 - 826.9)

Volume	Invert	Avail.Storage	Storage Description
#1	952.00'	1.352 af	Custom Stage Data (Conic) Listed below (Recalc)
Elevation (feet)	Surf.Area (acres)	Inc.Store (acre-feet)	Cum.Store (acre-feet) Wet.Area (acres)
952.00	0.100	0.000	0.000 0.100
953.00	0.220	0.156	0.156 0.220
954.00	0.610	0.399	0.555 0.610
955.00	1.000	0.797	1.352 1.001

Device	Routing	Invert	Outlet Devices
#1	Discarded	952.00'	0.500 in/hr Exfiltration over Surface area Conductivity to Groundwater Elevation = 942.00' Phase-In= 0.01'
#2	Primary	954.00'	10.0' long x 10.0' breadth Broad-Crested Rectangular Weir Head (feet) 0.20 0.40 0.60 0.80 1.00 1.20 1.40 1.60 Coef. (English) 2.49 2.56 2.70 2.69 2.68 2.69 2.67 2.64

Discarded OutFlow Max=0.37 cfs @ 13.22 hrs HW=954.17' (Free Discharge)
 ↑1=Exfiltration (Controls 0.37 cfs)

Primary OutFlow Max=1.78 cfs @ 13.22 hrs HW=954.17' TW=950.84' (Dynamic Tailwater)
 ↑2=Broad-Crested Rectangular Weir(Weir Controls 1.78 cfs @ 1.03 fps)

Pond 5D: Depression

Hydrograph

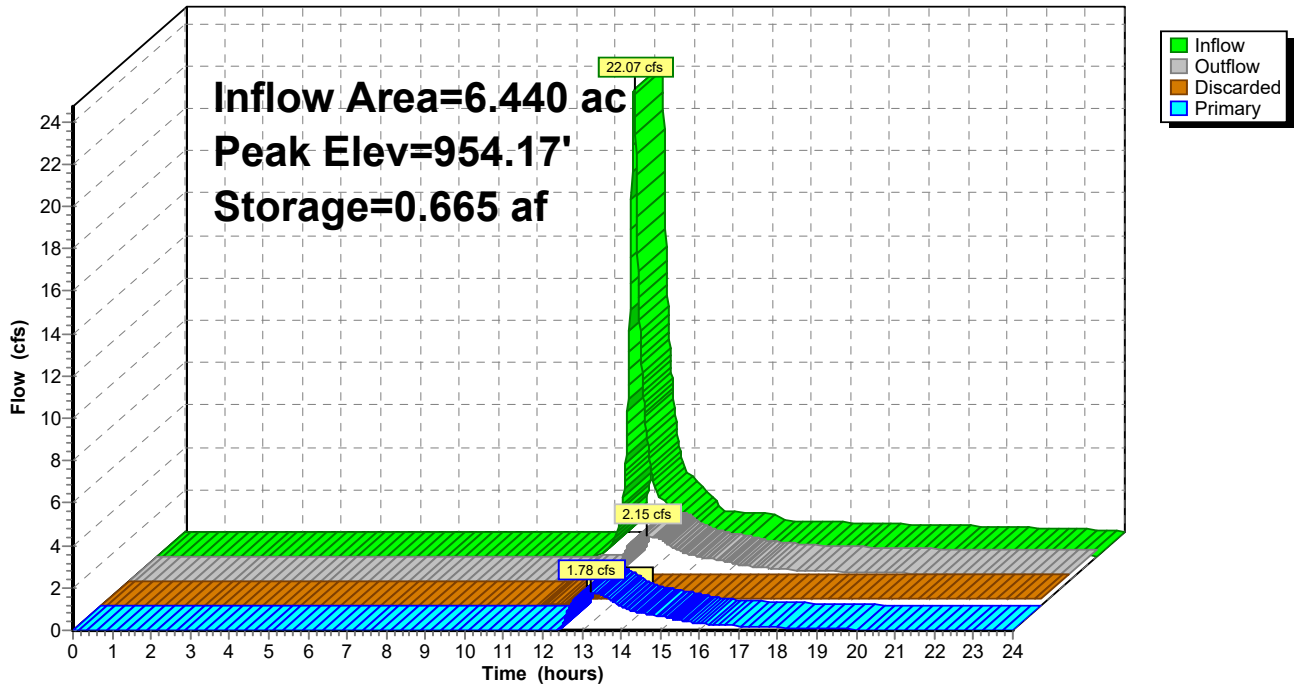

Proposed_2026-002

MSE 24-hr 3 100 yr Rainfall=6.18"

Prepared by Sound Stormwater Design

Printed 5/13/2026

HydroCAD® 10.20-4c s/n 11025 © 2024 HydroCAD Software Solutions LLC

Page 140

Summary for Pond 6B: Basin

Inflow Area = 12.900 ac, 12.71% Impervious, Inflow Depth > 2.57" for 100 yr event
 Inflow = 50.14 cfs @ 12.19 hrs, Volume= 2.765 af
 Outflow = 4.17 cfs @ 13.39 hrs, Volume= 2.298 af, Atten= 92%, Lag= 71.9 min
 Discarded = 0.14 cfs @ 13.39 hrs, Volume= 0.120 af
 Primary = 4.03 cfs @ 13.39 hrs, Volume= 2.178 af
 Routed to Pond 7D : Depression

Routing by Sim-Route method, Time Span= 0.00-24.00 hrs, dt= 0.01 hrs
 Peak Elev= 960.14' @ 13.39 hrs Surf.Area= 0.901 ac Storage= 1.541 af

Plug-Flow detention time= 223.5 min calculated for 2.298 af (83% of inflow)
 Center-of-Mass det. time= 161.9 min (982.4 - 820.6)

Volume	Invert	Avail.Storage	Storage Description		
#1	958.25'	2.594 af	Custom Stage Data (Conic) Listed below (Recalc)		
Elevation (feet)	Surf.Area (acres)	Inc.Store (acre-feet)	Cum.Store (acre-feet)	Wet.Area (acres)	
958.25	0.710	0.000	0.000	0.710	
959.00	0.810	0.570	0.570	0.811	
960.00	0.890	0.850	1.419	0.892	
961.00	0.970	0.930	2.349	0.974	
961.25	0.990	0.245	2.594	0.994	

Device	Routing	Invert	Outlet Devices
#1	Discarded	958.25'	0.110 in/hr Exfiltration over Surface area Conductivity to Groundwater Elevation = 953.60' Phase-In= 0.01'
#2	Primary	958.50'	12.0" Round Culvert L= 56.0' CPP, end-section conforming to fill, Ke= 0.500 Inlet / Outlet Invert= 958.50' / 958.00' S= 0.0089 '/' Cc= 0.900 n= 0.011, Flow Area= 0.79 sf
#3	Primary	960.25'	10.0' long x 10.0' breadth Broad-Crested Rectangular Weir Head (feet) 0.20 0.40 0.60 0.80 1.00 1.20 1.40 1.60 Coef. (English) 2.49 2.56 2.70 2.69 2.68 2.69 2.67 2.64

Discarded OutFlow Max=0.14 cfs @ 13.39 hrs HW=960.14' (Free Discharge)
 ↑1=Exfiltration (Controls 0.14 cfs)

Primary OutFlow Max=4.03 cfs @ 13.39 hrs HW=960.14' TW=957.18' (Dynamic Tailwater)
 ↑2=Culvert (Inlet Controls 4.03 cfs @ 5.13 fps)
 ↑3=Broad-Crested Rectangular Weir (Controls 0.00 cfs)

Pond 6B: Basin

Hydrograph

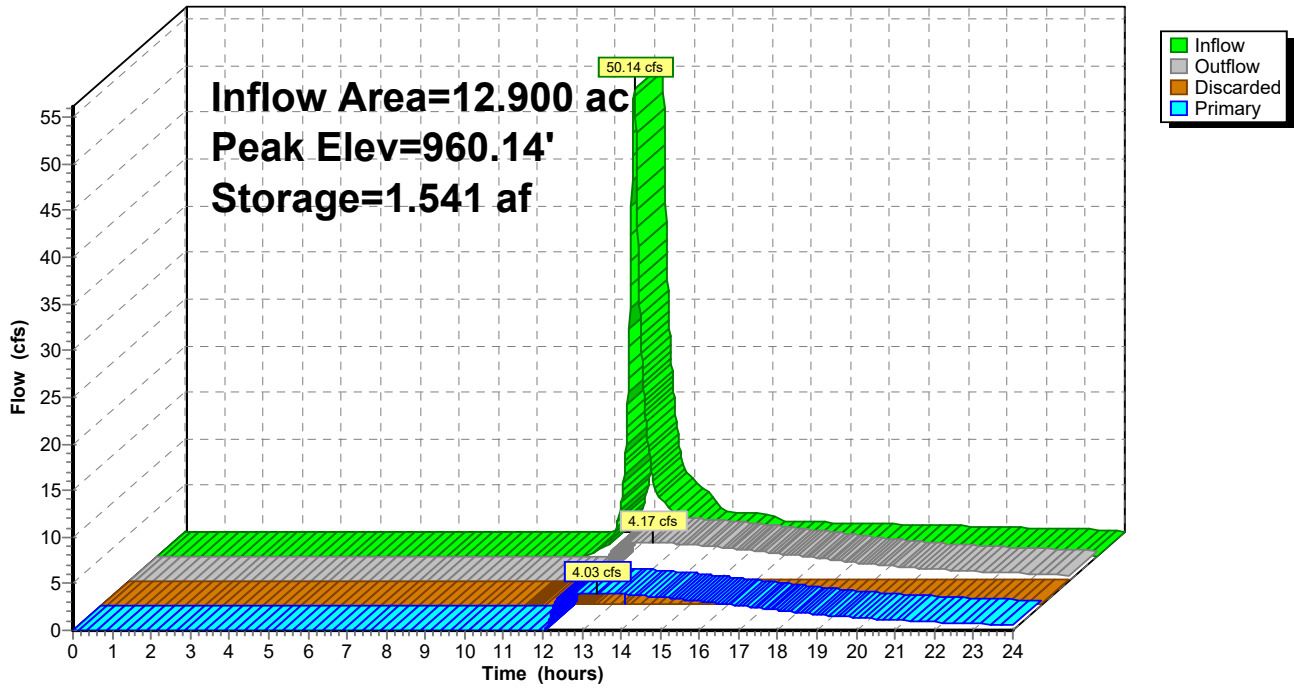

Summary for Pond 7D: Depression

Inflow Area = 18.860 ac, 10.82% Impervious, Inflow Depth > 2.11" for 100 yr event
 Inflow = 22.73 cfs @ 12.18 hrs, Volume= 3.321 af
 Outflow = 21.36 cfs @ 12.22 hrs, Volume= 3.321 af, Atten= 6%, Lag= 2.3 min
 Discarded = 0.14 cfs @ 12.22 hrs, Volume= 0.016 af
 Primary = 21.22 cfs @ 12.22 hrs, Volume= 3.305 af
 Routed to Link 1L : Discharge to County Road I

Routing by Sim-Route method, Time Span= 0.00-24.00 hrs, dt= 0.01 hrs
 Peak Elev= 957.51' @ 12.22 hrs Surf.Area= 0.264 ac Storage= 0.113 af

Plug-Flow detention time= 2.8 min calculated for 3.319 af (100% of inflow)
 Center-of-Mass det. time= 2.8 min (928.7 - 926.0)

Volume	Invert	Avail.Storage	Storage Description		
#1	954.30'	1.157 af	Custom Stage Data (Conic) Listed below (Recalc)		
Elevation (feet)	Surf.Area (acres)	Inc.Store (acre-feet)	Cum.Store (acre-feet)	Wet.Area (acres)	
954.30	0.000	0.000	0.000	0.000	
955.00	0.001	0.000	0.000	0.001	
956.00	0.010	0.005	0.005	0.010	
957.00	0.060	0.031	0.036	0.060	
958.00	0.600	0.283	0.320	0.600	
959.00	1.100	0.837	1.157	1.100	

Device	Routing	Invert	Outlet Devices
#1	Discarded	954.30'	0.500 in/hr Exfiltration over Surface area Conductivity to Groundwater Elevation = 951.00' Phase-In= 0.01'
#2	Primary	954.80'	15.0" Round Culvert L= 30.0' CMP, end-section conforming to fill, Ke= 0.500 Inlet / Outlet Invert= 954.30' / 954.80' S= -0.0167 '/' Cc= 0.900 n= 0.024, Flow Area= 1.23 sf
#3	Primary	957.30'	60.0' long x 10.0' breadth Broad-Crested Rectangular Weir Head (feet) 0.20 0.40 0.60 0.80 1.00 1.20 1.40 1.60 Coef. (English) 2.49 2.56 2.70 2.69 2.68 2.69 2.67 2.64

Discarded OutFlow Max=0.14 cfs @ 12.22 hrs HW=957.51' (Free Discharge)
 ↑1=Exfiltration (Controls 0.14 cfs)

Primary OutFlow Max=21.21 cfs @ 12.22 hrs HW=957.51' TW=0.00' (Dynamic Tailwater)
 ↑2=Culvert (Barrel Controls 6.99 cfs @ 5.70 fps)
 ↑3=Broad-Crested Rectangular Weir(Weir Controls 14.21 cfs @ 1.14 fps)

Pond 7D: Depression

Hydrograph

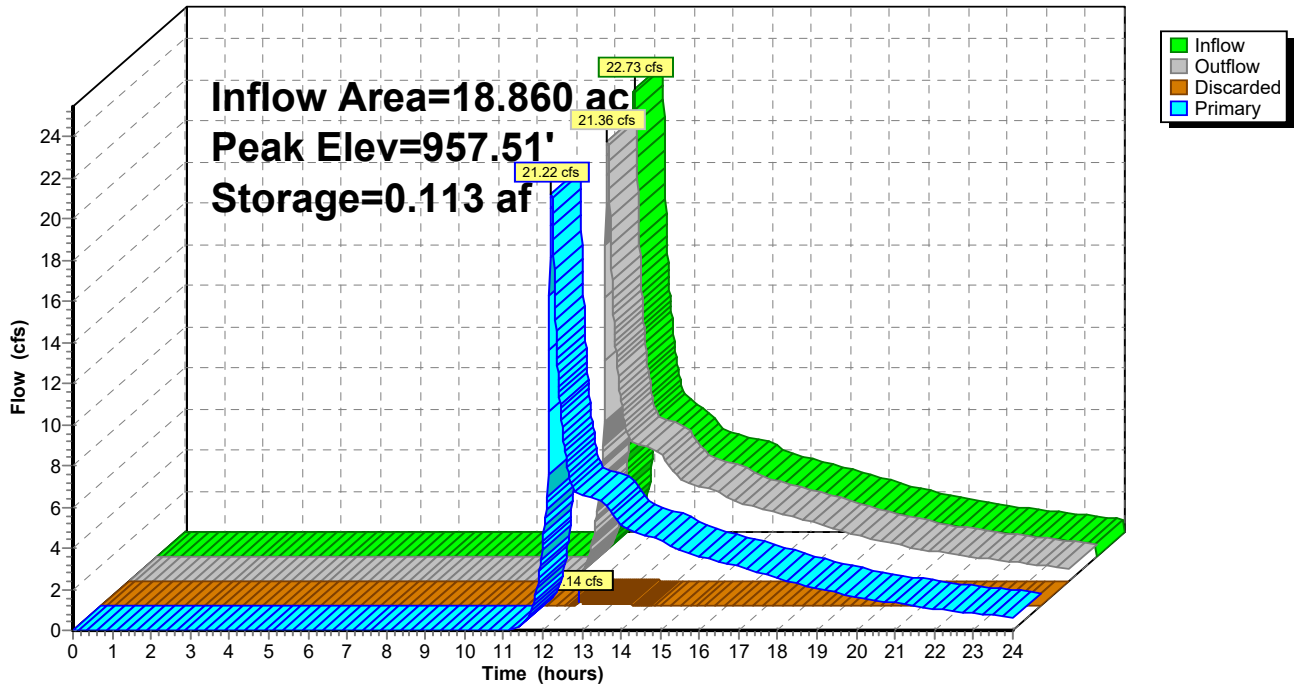

Proposed_2026-002

MSE 24-hr 3 100 yr Rainfall=6.18"

Prepared by Sound Stormwater Design

Printed 5/13/2026

HydroCAD® 10.20-4c s/n 11025 © 2024 HydroCAD Software Solutions LLC

Page 144

Summary for Pond 8B: Basin

Inflow Area = 4.280 ac, 15.42% Impervious, Inflow Depth > 2.66" for 100 yr event
 Inflow = 17.29 cfs @ 12.19 hrs, Volume= 0.950 af
 Outflow = 2.53 cfs @ 12.71 hrs, Volume= 0.914 af, Atten= 85%, Lag= 31.6 min
 Discarded = 0.03 cfs @ 12.71 hrs, Volume= 0.017 af
 Primary = 2.50 cfs @ 12.71 hrs, Volume= 0.897 af
 Routed to Link 1L : Discharge to County Road I

Routing by Sim-Route method, Time Span= 0.00-24.00 hrs, dt= 0.01 hrs
 Peak Elev= 974.80' @ 12.71 hrs Surf.Area= 0.245 ac Storage= 0.436 af

Plug-Flow detention time= 101.6 min calculated for 0.914 af (96% of inflow)
 Center-of-Mass det. time= 81.6 min (900.4 - 818.8)

Volume	Invert	Avail.Storage	Storage Description		
#1	972.00'	0.791 af	Custom Stage Data (Conic) Listed below (Recalc)		
Elevation (feet)	Surf.Area (acres)	Inc.Store (acre-feet)	Cum.Store (acre-feet)	Wet.Area (acres)	
972.00	0.080	0.000	0.000	0.080	
973.00	0.130	0.104	0.104	0.130	
974.00	0.190	0.159	0.263	0.191	
975.00	0.260	0.224	0.487	0.261	
976.00	0.350	0.304	0.791	0.352	

Device	Routing	Invert	Outlet Devices
#1	Discarded	972.00'	0.110 in/hr Exfiltration over Surface area Conductivity to Groundwater Elevation = 953.60' Phase-In= 0.01'
#2	Primary	972.25'	8.0" Round Culvert L= 44.0' CPP, end-section conforming to fill, Ke= 0.500 Inlet / Outlet Invert= 972.25' / 971.00' S= 0.0284 '/' Cc= 0.900 n= 0.011, Flow Area= 0.35 sf
#3	Primary	975.00'	10.0' long x 10.0' breadth Broad-Crested Rectangular Weir Head (feet) 0.20 0.40 0.60 0.80 1.00 1.20 1.40 1.60 Coef. (English) 2.49 2.56 2.70 2.69 2.68 2.69 2.67 2.64

Discarded OutFlow Max=0.03 cfs @ 12.71 hrs HW=974.80' (Free Discharge)
 ↑1=Exfiltration (Controls 0.03 cfs)

Primary OutFlow Max=2.50 cfs @ 12.71 hrs HW=974.80' TW=0.00' (Dynamic Tailwater)
 ↑2=Culvert (Inlet Controls 2.50 cfs @ 7.16 fps)
 ↑3=Broad-Crested Rectangular Weir (Controls 0.00 cfs)

Pond 8B: Basin

Hydrograph

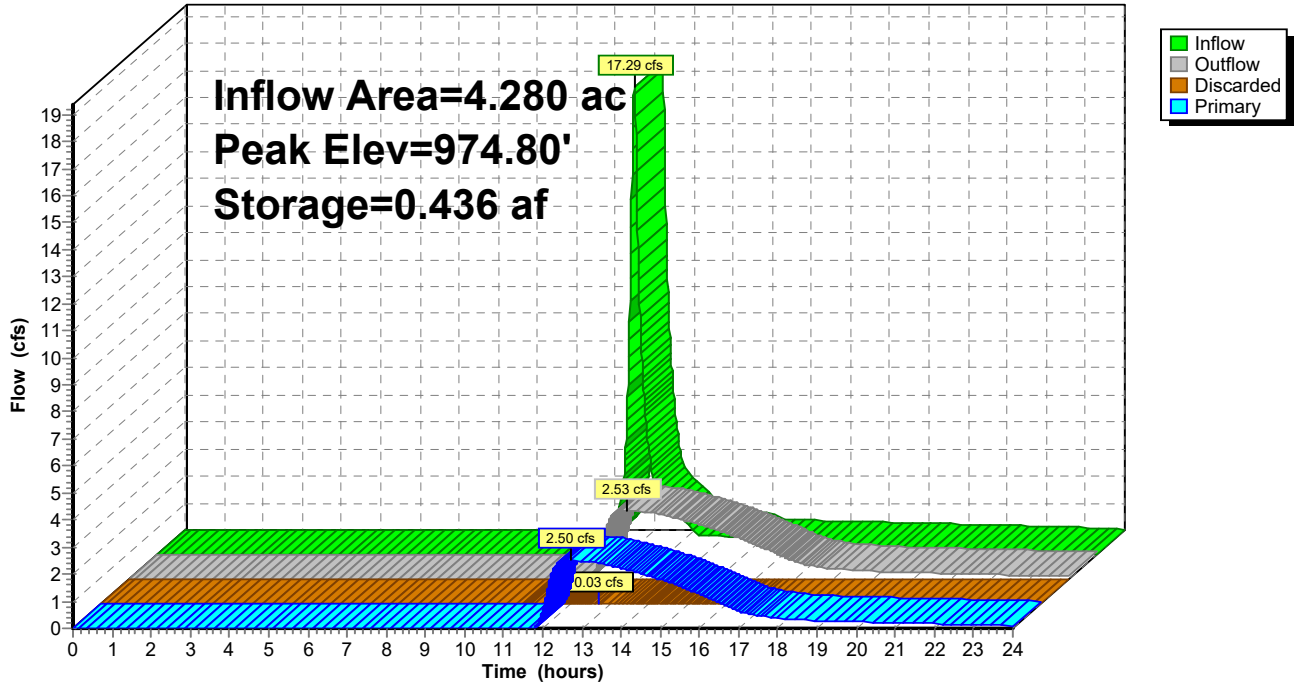

Proposed_2026-002

MSE 24-hr 3 100 yr Rainfall=6.18"

Prepared by Sound Stormwater Design

Printed 5/13/2026

HydroCAD® 10.20-4c s/n 11025 © 2024 HydroCAD Software Solutions LLC

Page 146

Summary for Pond 9B: Basin

[86] Warning: Oscillations may require smaller dt (severity=3)

Inflow = 36.34 cfs @ 12.24 hrs, Volume= 2.454 af
 Outflow = 7.13 cfs @ 12.71 hrs, Volume= 1.522 af, Atten= 80%, Lag= 27.9 min
 Discarded = 0.52 cfs @ 12.77 hrs, Volume= 0.504 af
 Primary = 3.64 cfs @ 12.60 hrs, Volume= 0.251 af
 Routed to Pond 10B : Basin
 Secondary = 3.36 cfs @ 12.77 hrs, Volume= 0.767 af
 Routed to Link 2L : Discharge South

Routing by Sim-Route method, Time Span= 0.00-24.00 hrs, dt= 0.01 hrs
Peak Elev= 963.98' @ 12.77 hrs Surf.Area= 0.628 ac Storage= 1.111 af

Plug-Flow detention time= 185.8 min calculated for 1.522 af (62% of inflow)
Center-of-Mass det. time= 97.0 min (926.8 - 829.8)

Volume	Invert	Avail.Storage	Storage Description		
#1	962.00'	1.789 af	Custom Stage Data (Conic) Listed below (Recalc)		
Elevation (feet)	Surf.Area (acres)	Inc.Store (acre-feet)	Cum.Store (acre-feet)	Wet.Area (acres)	
962.00	0.500	0.000	0.000	0.500	
963.00	0.560	0.530	0.530	0.561	
964.00	0.630	0.595	1.124	0.632	
965.00	0.700	0.665	1.789	0.704	

Device	Routing	Invert	Outlet Devices	
#1	Discarded	962.00'	0.500 in/hr Exfiltration over Surface area Conductivity to Groundwater Elevation = 959.30' Phase-In= 0.01'	
#2	Primary	962.00'	15.0" Round Culvert L= 210.0' CPP, end-section conforming to fill, Ke= 0.500 Inlet / Outlet Invert= 962.00' / 962.00' S= 0.0000 '/' Cc= 0.900 n= 0.011, Flow Area= 1.23 sf	
#3	Secondary	963.75'	36.0" Horiz. Grate C= 0.600 Limited to weir flow at low heads	
#4	Secondary	964.00'	10.0' long x 10.0' breadth Broad-Crested Rectangular Weir Head (feet) 0.20 0.40 0.60 0.80 1.00 1.20 1.40 1.60 Coef. (English) 2.49 2.56 2.70 2.69 2.68 2.69 2.67 2.64	

Discarded OutFlow Max=0.52 cfs @ 12.77 hrs HW=963.98' (Free Discharge)
↑1=Exfiltration (Controls 0.52 cfs)

Primary OutFlow Max=3.60 cfs @ 12.60 hrs HW=963.93' TW=963.27' (Dynamic Tailwater)
↑2=Culvert (Outlet Controls 3.60 cfs @ 2.93 fps)

Secondary OutFlow Max=3.36 cfs @ 12.77 hrs HW=963.98' TW=0.00' (Dynamic Tailwater)
↑3=Grate (Weir Controls 3.36 cfs @ 1.56 fps)
↑4=Broad-Crested Rectangular Weir(Controls 0.00 cfs)

Pond 9B: Basin

Hydrograph

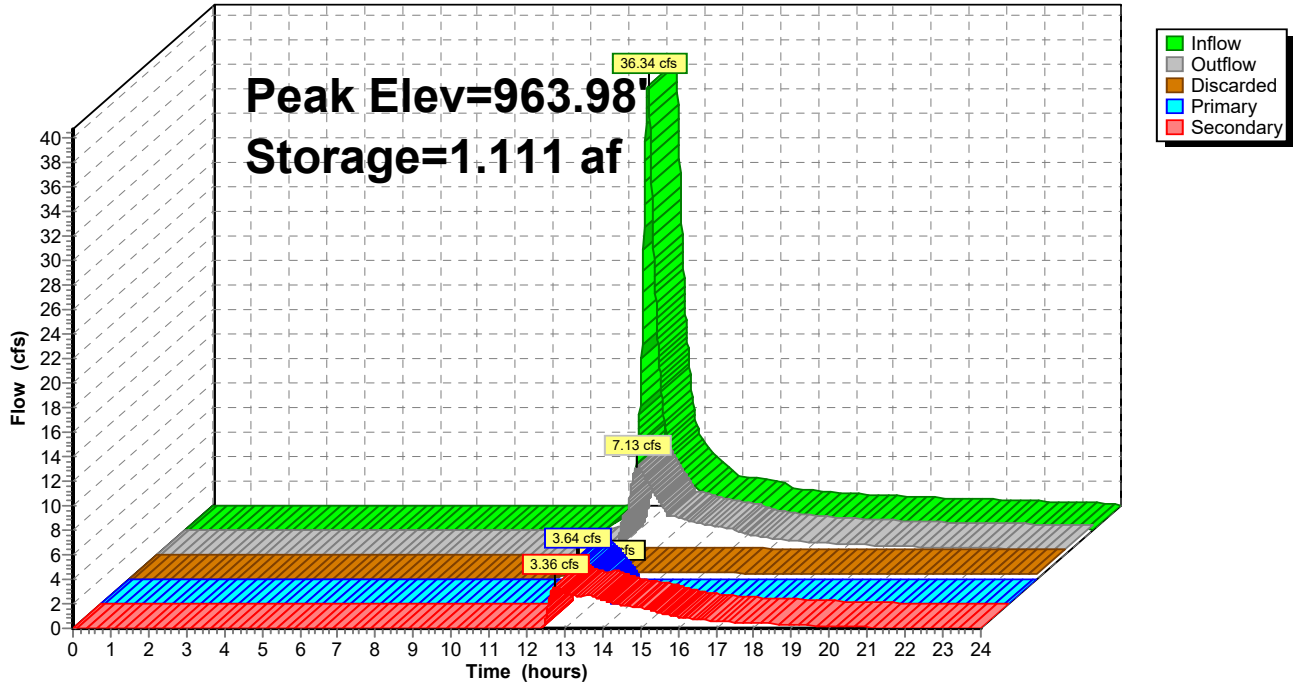

Summary for Pond 10B: Basin

[86] Warning: Oscillations may require smaller dt (severity=26)

Inflow = 11.45 cfs @ 12.25 hrs, Volume= 0.891 af
 Outflow = 0.79 cfs @ 14.00 hrs, Volume= 0.333 af, Atten= 93%, Lag= 104.8 min
 Discarded = 0.23 cfs @ 13.72 hrs, Volume= 0.223 af
 Primary = 0.56 cfs @ 14.00 hrs, Volume= 0.110 af
 Routed to Pond 9B : Basin
 Secondary = 0.00 cfs @ 0.00 hrs, Volume= 0.000 af
 Routed to Link 2L : Discharge South

Routing by Sim-Route method, Time Span= 0.00-24.00 hrs, dt= 0.01 hrs
 Peak Elev= 963.95' @ 13.72 hrs Surf.Area= 0.397 ac Storage= 0.661 af

Plug-Flow detention time= 287.3 min calculated for 0.333 af (37% of inflow)
 Center-of-Mass det. time= 207.2 min (1,021.1 - 814.0)

Volume	Invert	Avail.Storage	Storage Description		
#1	962.00'	1.109 af	Custom Stage Data (Conic) Listed below (Recalc)		
Elevation (feet)	Surf.Area (acres)	Inc.Store (acre-feet)	Cum.Store (acre-feet)	Wet.Area (acres)	
962.00	0.280	0.000	0.000	0.280	
963.00	0.340	0.310	0.310	0.341	
964.00	0.400	0.370	0.679	0.402	
965.00	0.460	0.430	1.109	0.463	

Device	Routing	Invert	Outlet Devices	
#1	Discarded	962.00'	0.500 in/hr Exfiltration over Surface area Conductivity to Groundwater Elevation = 951.00' Phase-In= 0.01'	
#2	Primary	962.00'	15.0" Round Culvert L= 210.0' CPP, end-section conforming to fill, Ke= 0.500 Inlet / Outlet Invert= 962.00' / 962.00' S= 0.0000 '/' Cc= 0.900 n= 0.011, Flow Area= 1.23 sf	
#3	Secondary	964.00'	10.0' long x 10.0' breadth Broad-Crested Rectangular Weir Head (feet) 0.20 0.40 0.60 0.80 1.00 1.20 1.40 1.60 Coef. (English) 2.49 2.56 2.70 2.69 2.68 2.69 2.67 2.64	

Discarded OutFlow Max=0.23 cfs @ 13.72 hrs HW=963.95' (Free Discharge)
 ↑1=Exfiltration (Controls 0.23 cfs)

Primary OutFlow Max=0.57 cfs @ 14.00 hrs HW=963.94' TW=963.93' (Dynamic Tailwater)
 ↑2=Culvert (Outlet Controls 0.57 cfs @ 0.46 fps)

Secondary OutFlow Max=0.00 cfs @ 0.00 hrs HW=962.00' TW=0.00' (Dynamic Tailwater)
 ↑3=Broad-Crested Rectangular Weir(Controls 0.00 cfs)

Pond 10B: Basin

Hydrograph

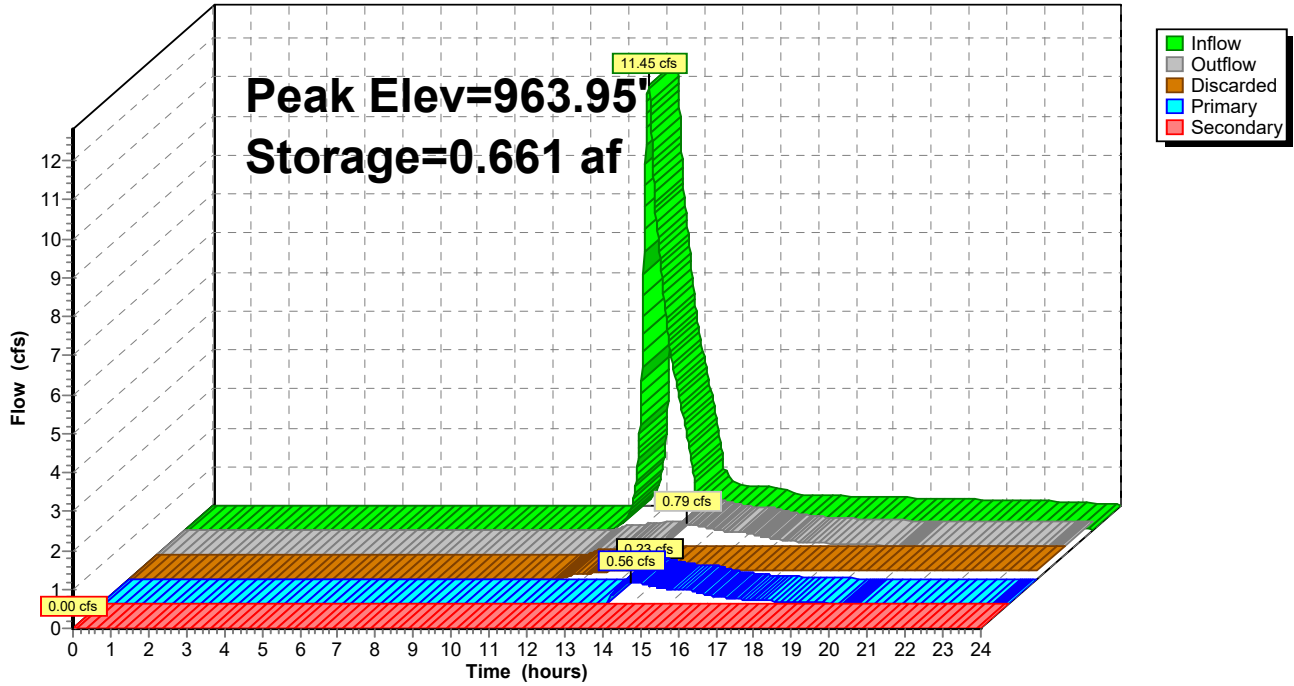

Summary for Link 1L: Discharge to County Road I

Inflow Area = 25.220 ac, 12.85% Impervious, Inflow Depth > 2.24" for 100 yr event
Inflow = 30.98 cfs @ 12.21 hrs, Volume= 4.717 af
Primary = 30.98 cfs @ 12.22 hrs, Volume= 4.717 af, Atten= 0%, Lag= 0.6 min

Primary outflow = Inflow, Time Span= 0.00-24.00 hrs, dt= 0.01 hrs

Link 1L: Discharge to County Road I

Hydrograph

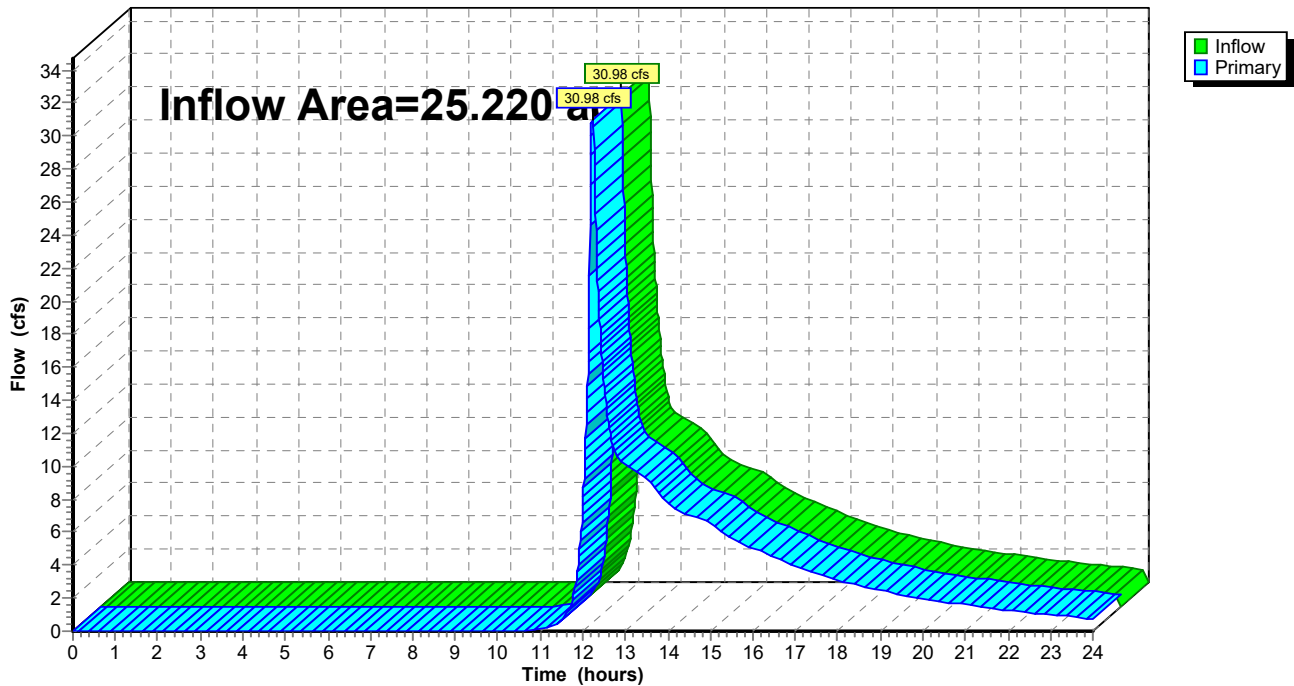

Summary for Link 2L: Discharge South

Inflow = 7.91 cfs @ 12.17 hrs, Volume= 1.170 af
Primary = 7.91 cfs @ 12.18 hrs, Volume= 1.170 af, Atten= 0%, Lag= 0.6 min

Primary outflow = Inflow, Time Span= 0.00-24.00 hrs, dt= 0.01 hrs

Link 2L: Discharge South

Hydrograph

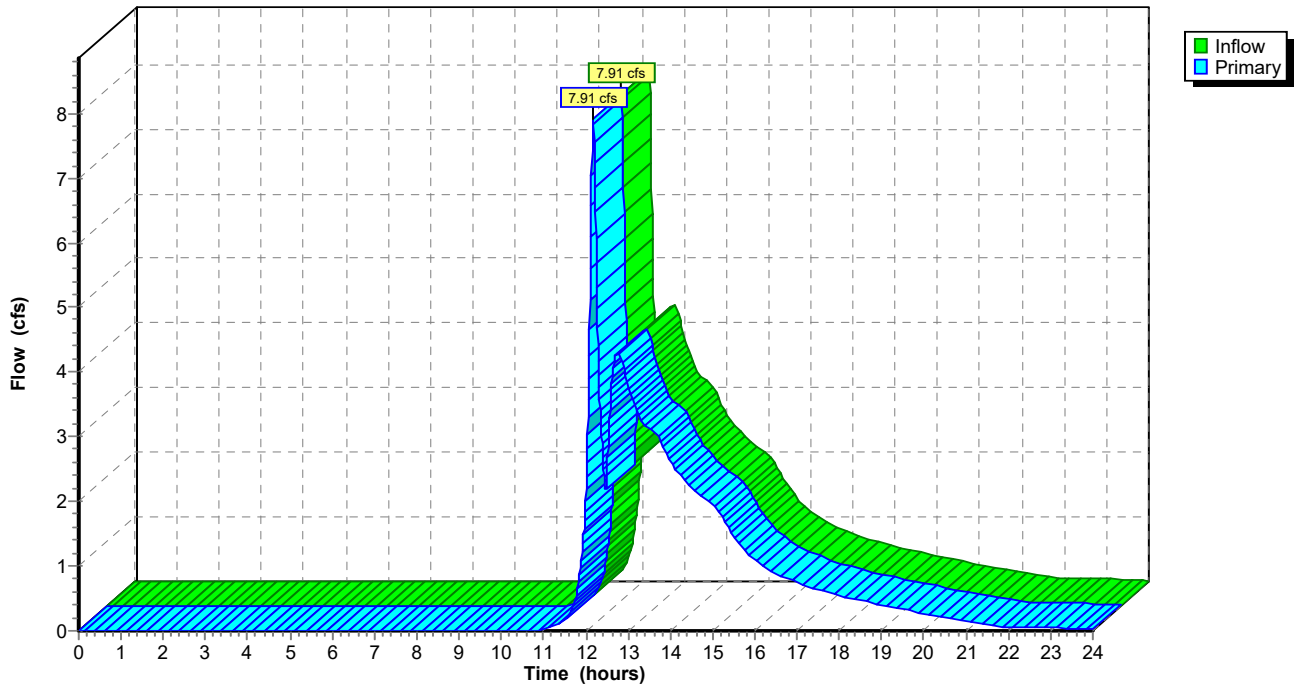

Proposed_2026-002

Prepared by Sound Stormwater Design

HydroCAD® 10.20-4c s/n 11025 © 2024 HydroCAD Software Solutions LLC

Multi-Event Tables

Printed 5/13/2026

Page 152

Events for Subcatchment E1: Subarea

Event	Rainfall (inches)	Runoff (cfs)	Volume (acre-feet)	Depth (inches)
1 yr	2.40	3.58	0.309	0.29
2 yr	2.70	6.00	0.439	0.41
10 yr	3.81	17.66	1.046	0.97
100 yr	6.18	50.14	2.765	2.57

Proposed_2026-002

Prepared by Sound Stormwater Design

HydroCAD® 10.20-4c s/n 11025 © 2024 HydroCAD Software Solutions LLC

Multi-Event Tables

Printed 5/13/2026

Page 153

Events for Subcatchment E2: Subarea

Event	Rainfall (inches)	Runoff (cfs)	Volume (acre-feet)	Depth (inches)
1 yr	2.40	0.94	0.105	0.21
2 yr	2.70	1.86	0.156	0.31
10 yr	3.81	6.84	0.405	0.82
100 yr	6.18	21.49	1.143	2.30

Proposed_2026-002

Prepared by Sound Stormwater Design

HydroCAD® 10.20-4c s/n 11025 © 2024 HydroCAD Software Solutions LLC

Multi-Event Tables

Printed 5/13/2026

Page 154

Events for Subcatchment E3: Subarea

Event	Rainfall (inches)	Runoff (cfs)	Volume (acre-feet)	Depth (inches)
1 yr	2.40	1.41	0.112	0.32
2 yr	2.70	2.26	0.158	0.44
10 yr	3.81	6.29	0.367	1.03
100 yr	6.18	17.29	0.950	2.66

Proposed_2026-002

Prepared by Sound Stormwater Design

HydroCAD® 10.20-4c s/n 11025 © 2024 HydroCAD Software Solutions LLC

Multi-Event Tables

Printed 5/13/2026

Page 155

Events for Subcatchment E4: Subarea

Event	Rainfall (inches)	Runoff (cfs)	Volume (acre-feet)	Depth (inches)
1 yr	2.40	0.41	0.025	0.32
2 yr	2.70	0.66	0.035	0.44
10 yr	3.81	1.76	0.081	1.03
100 yr	6.18	4.73	0.211	2.67

Proposed_2026-002

Prepared by Sound Stormwater Design

HydroCAD® 10.20-4c s/n 11025 © 2024 HydroCAD Software Solutions LLC

Multi-Event Tables

Printed 5/13/2026

Page 156

Events for Subcatchment E5: Subarea

Event	Rainfall (inches)	Runoff (cfs)	Volume (acre-feet)	Depth (inches)
1 yr	2.40	0.74	0.048	0.51
2 yr	2.70	1.02	0.064	0.68
10 yr	3.81	2.24	0.131	1.39
100 yr	6.18	5.29	0.305	3.24

Proposed_2026-002

Prepared by Sound Stormwater Design

HydroCAD® 10.20-4c s/n 11025 © 2024 HydroCAD Software Solutions LLC

Multi-Event Tables

Printed 5/13/2026

Page 157

Events for Subcatchment N1: Subarea

Event	Rainfall (inches)	Runoff (cfs)	Volume (acre-feet)	Depth (inches)
1 yr	2.40	4.41	0.467	0.31
2 yr	2.70	7.01	0.655	0.44
10 yr	3.81	19.61	1.523	1.03
100 yr	6.18	54.65	3.945	2.66

Proposed_2026-002

Prepared by Sound Stormwater Design

HydroCAD® 10.20-4c s/n 11025 © 2024 HydroCAD Software Solutions LLC

Multi-Event Tables

Printed 5/13/2026

Page 158

Events for Subcatchment N2: Subarea

Event	Rainfall (inches)	Runoff (cfs)	Volume (acre-feet)	Depth (inches)
1 yr	2.40	3.73	0.240	0.41
2 yr	2.70	5.49	0.325	0.55
10 yr	3.81	13.21	0.707	1.20
100 yr	6.18	33.31	1.731	2.95

Proposed_2026-002

Prepared by Sound Stormwater Design

HydroCAD® 10.20-4c s/n 11025 © 2024 HydroCAD Software Solutions LLC

Multi-Event Tables

Printed 5/13/2026

Page 159

Events for Subcatchment N3: Subarea

Event	Rainfall (inches)	Runoff (cfs)	Volume (acre-feet)	Depth (inches)
1 yr	2.40	8.02	0.913	0.41
2 yr	2.70	11.71	1.239	0.55
10 yr	3.81	28.83	2.695	1.20
100 yr	6.18	74.17	6.600	2.94

Proposed_2026-002

Prepared by Sound Stormwater Design

HydroCAD® 10.20-4c s/n 11025 © 2024 HydroCAD Software Solutions LLC

Multi-Event Tables

Printed 5/13/2026

Page 160

Events for Subcatchment N4: Subarea

Event	Rainfall (inches)	Runoff (cfs)	Volume (acre-feet)	Depth (inches)
1 yr	2.40	3.15	0.364	0.21
2 yr	2.70	6.13	0.542	0.31
10 yr	3.81	22.55	1.407	0.82
100 yr	6.18	71.35	3.969	2.30

Proposed_2026-002

Prepared by Sound Stormwater Design

HydroCAD® 10.20-4c s/n 11025 © 2024 HydroCAD Software Solutions LLC

Multi-Event Tables

Printed 5/13/2026

Page 161

Events for Subcatchment S1: Subarea

Event	Rainfall (inches)	Runoff (cfs)	Volume (acre-feet)	Depth (inches)
1 yr	2.40	2.26	0.246	0.26
2 yr	2.70	3.90	0.355	0.38
10 yr	3.81	12.28	0.868	0.92
100 yr	6.18	36.34	2.344	2.48

Proposed_2026-002

Prepared by Sound Stormwater Design

HydroCAD® 10.20-4c s/n 11025 © 2024 HydroCAD Software Solutions LLC

Multi-Event Tables

Printed 5/13/2026

Page 162

Events for Subcatchment S2: Subarea

Event	Rainfall (inches)	Runoff (cfs)	Volume (acre-feet)	Depth (inches)
1 yr	2.40	0.38	0.054	0.19
2 yr	2.70	0.75	0.082	0.29
10 yr	3.81	2.99	0.221	0.77
100 yr	6.18	9.93	0.640	2.21

Proposed_2026-002

Prepared by Sound Stormwater Design

HydroCAD® 10.20-4c s/n 11025 © 2024 HydroCAD Software Solutions LLC

Multi-Event Tables

Printed 5/13/2026

Page 163

Events for Subcatchment S3: Subarea

Event	Rainfall (inches)	Runoff (cfs)	Volume (acre-feet)	Depth (inches)
1 yr	2.40	0.50	0.042	0.26
2 yr	2.70	0.87	0.061	0.38
10 yr	3.81	2.72	0.149	0.92
100 yr	6.18	7.91	0.403	2.48

Proposed_2026-002

Prepared by Sound Stormwater Design

HydroCAD® 10.20-4c s/n 11025 © 2024 HydroCAD Software Solutions LLC

Multi-Event Tables

Printed 5/13/2026

Page 164

Events for Subcatchment W1: Subarea

Event	Rainfall (inches)	Runoff (cfs)	Volume (acre-feet)	Depth (inches)
1 yr	2.40	0.79	0.101	0.19
2 yr	2.70	1.65	0.153	0.29
10 yr	3.81	6.71	0.411	0.77
100 yr	6.18	22.07	1.188	2.21

Proposed_2026-002

Prepared by Sound Stormwater Design

HydroCAD® 10.20-4c s/n 11025 © 2024 HydroCAD Software Solutions LLC

Multi-Event Tables

Printed 5/13/2026

Page 165

Events for Pond 1D: Depression

Event	Inflow (cfs)	Outflow (cfs)	Discarded (cfs)	Primary (cfs)	Elevation (feet)	Storage (acre-feet)
1 yr	4.41	0.49	0.19	0.30	975.04	0.264
2 yr	7.01	1.55	0.22	1.33	975.11	0.290
10 yr	19.61	10.24	0.37	9.87	975.40	0.452
100 yr	54.65	35.74	0.74	35.00	975.91	0.968

Proposed_2026-002

Prepared by Sound Stormwater Design

HydroCAD® 10.20-4c s/n 11025 © 2024 HydroCAD Software Solutions LLC

Multi-Event Tables

Printed 5/13/2026

Page 166

Events for Pond 2D: Depression

Event	Inflow (cfs)	Outflow (cfs)	Discarded (cfs)	Primary (cfs)	Elevation (feet)	Storage (acre-feet)
1 yr	3.73	0.75	0.12	0.63	970.46	0.078
2 yr	5.49	1.53	0.16	1.37	970.69	0.139
10 yr	13.21	4.94	0.31	4.63	971.78	0.621
100 yr	45.43	28.27	0.58	27.68	973.64	2.017

Proposed_2026-002

Prepared by Sound Stormwater Design

HydroCAD® 10.20-4c s/n 11025 © 2024 HydroCAD Software Solutions LLC

Multi-Event Tables

Printed 5/13/2026

Page 167

Events for Pond 3D: Depression

Event	Inflow (cfs)	Outflow (cfs)	Discarded (cfs)	Primary (cfs)	Elevation (feet)	Storage (acre-feet)
1 yr	8.58	7.59	0.04	7.56	952.66	0.029
2 yr	12.64	12.63	0.05	12.59	952.81	0.041
10 yr	31.86	31.82	0.06	31.75	953.02	0.063
100 yr	80.62	80.59	0.09	80.51	953.36	0.110

Proposed_2026-002

Prepared by Sound Stormwater Design

HydroCAD® 10.20-4c s/n 11025 © 2024 HydroCAD Software Solutions LLC

Multi-Event Tables

Printed 5/13/2026

Page 168

Events for Pond 4K: Kettle

Event	Inflow (cfs)	Discarded (cfs)	Elevation (feet)	Storage (acre-feet)
1 yr	9.45	0.62	946.98	1.297
2 yr	16.12	0.73	947.48	1.889
10 yr	42.06	1.17	949.33	4.836
100 yr	116.12	2.40	952.70	13.641

Proposed_2026-002

Prepared by Sound Stormwater Design

HydroCAD® 10.20-4c s/n 11025 © 2024 HydroCAD Software Solutions LLC

Multi-Event Tables

Printed 5/13/2026

Page 169

Events for Pond 5D: Depression

Event	Inflow (cfs)	Outflow (cfs)	Discarded (cfs)	Primary (cfs)	Elevation (feet)	Storage (acre-feet)
1 yr	0.79	0.07	0.07	0.00	952.40	0.048
2 yr	1.65	0.09	0.09	0.00	952.64	0.086
10 yr	6.71	0.19	0.19	0.00	953.41	0.272
100 yr	22.07	2.15	0.37	1.78	954.17	0.665

Proposed_2026-002

Prepared by Sound Stormwater Design

HydroCAD® 10.20-4c s/n 11025 © 2024 HydroCAD Software Solutions LLC

Multi-Event Tables

Printed 5/13/2026

Page 170

Events for Pond 6B: Basin

Event	Inflow (cfs)	Outflow (cfs)	Discarded (cfs)	Primary (cfs)	Elevation (feet)	Storage (acre-feet)
1 yr	3.58	0.10	0.09	0.01	958.56	0.224
2 yr	6.00	0.20	0.09	0.11	958.66	0.300
10 yr	17.66	1.16	0.10	1.05	959.03	0.595
100 yr	50.14	4.17	0.14	4.03	960.14	1.541

Proposed_2026-002

Prepared by Sound Stormwater Design

HydroCAD® 10.20-4c s/n 11025 © 2024 HydroCAD Software Solutions LLC

Multi-Event Tables

Printed 5/13/2026

Page 171

Events for Pond 7D: Depression

Event	Inflow (cfs)	Outflow (cfs)	Discarded (cfs)	Primary (cfs)	Elevation (feet)	Storage (acre-feet)
1 yr	0.94	0.95	0.00	0.94	955.26	0.001
2 yr	1.86	1.86	0.00	1.86	955.47	0.001
10 yr	6.84	5.37	0.02	5.35	956.69	0.021
100 yr	22.73	21.36	0.14	21.22	957.51	0.113

Proposed_2026-002

Prepared by Sound Stormwater Design

HydroCAD® 10.20-4c s/n 11025 © 2024 HydroCAD Software Solutions LLC

Multi-Event Tables

Printed 5/13/2026

Page 172

Events for Pond 8B: Basin

Event	Inflow (cfs)	Outflow (cfs)	Discarded (cfs)	Primary (cfs)	Elevation (feet)	Storage (acre-feet)
1 yr	1.41	0.23	0.01	0.21	972.51	0.046
2 yr	2.26	0.42	0.01	0.41	972.62	0.058
10 yr	6.29	1.37	0.02	1.35	973.23	0.136
100 yr	17.29	2.53	0.03	2.50	974.80	0.436

Proposed_2026-002

Prepared by Sound Stormwater Design

HydroCAD® 10.20-4c s/n 11025 © 2024 HydroCAD Software Solutions LLC

Multi-Event Tables

Printed 5/13/2026

Page 173

Events for Pond 9B: Basin

Event	Inflow (cfs)	Outflow (cfs)	Discarded (cfs)	Primary (cfs)	Secondary (cfs)	Elevation (feet)	Storage (acre-feet)
1 yr	2.26	0.31	0.28	0.03	0.00	962.19	0.097
2 yr	3.90	0.40	0.29	0.11	0.00	962.32	0.162
10 yr	12.28	1.33	0.36	0.97	0.00	962.85	0.444
100 yr	36.34	7.13	0.52	3.64	3.36	963.98	1.111

Events for Pond 10B: Basin

Event	Inflow (cfs)	Outflow (cfs)	Discarded (cfs)	Primary (cfs)	Secondary (cfs)	Elevation (feet)	Storage (acre-feet)
1 yr	0.38	0.14	0.14	0.00	0.00	962.04	0.011
2 yr	0.76	0.15	0.15	0.00	0.00	962.15	0.042
10 yr	3.05	0.18	0.18	0.00	0.00	962.85	0.258
100 yr	11.45	0.79	0.23	0.56	0.00	963.95	0.661

Proposed_2026-002

Prepared by Sound Stormwater Design

HydroCAD® 10.20-4c s/n 11025 © 2024 HydroCAD Software Solutions LLC

Multi-Event Tables

Printed 5/13/2026

Page 175

Events for Link 1L: Discharge to County Road I

Event	Inflow (cfs)	Primary (cfs)	Elevation (feet)
1 yr	1.94	1.94	0.00
2 yr	3.31	3.31	0.00
10 yr	9.15	9.15	0.00
100 yr	30.98	30.98	0.00

Proposed_2026-002

Prepared by Sound Stormwater Design

HydroCAD® 10.20-4c s/n 11025 © 2024 HydroCAD Software Solutions LLC

Multi-Event Tables

Printed 5/13/2026

Page 176

Events for Link 2L: Discharge South

Event	Inflow (cfs)	Primary (cfs)	Elevation (feet)
1 yr	0.50	0.50	0.00
2 yr	0.87	0.87	0.00
10 yr	2.72	2.72	0.00
100 yr	7.91	7.91	0.00

APPENDIX C

Treatment Analysis / WinSLAMM

Treatment Analysis Results

FOR: Autumn Run

LOCATION: Town of Mukwonago, Wisconsin

TOTAL SUSPENDED SOLIDS (TSS)

Connected Model Total lbs without Controls = lbs (from WinSLAMM output)

Disconnected Model Total lbs with Controls = lbs (from WinSLAMM output)

Total lbs Removed = $5100 - 952.3 =$ lbs

% TSS Removed = $100 \times (4148 / 5100) =$ %

TOTAL PHOSPHORUS

Connected Model Total Phosphorus lbs without Controls = lbs (from WinSLAMM output)

Disconnected Model Total Phosphorus lbs with Controls = lbs (from WinSLAMM output)

Total lbs Removed = $28.86 - 5.016 =$ lbs

% Phosphorus Removed = $100 \times (23.84 / 28.86) =$ %

Treatment Analysis Connected Model

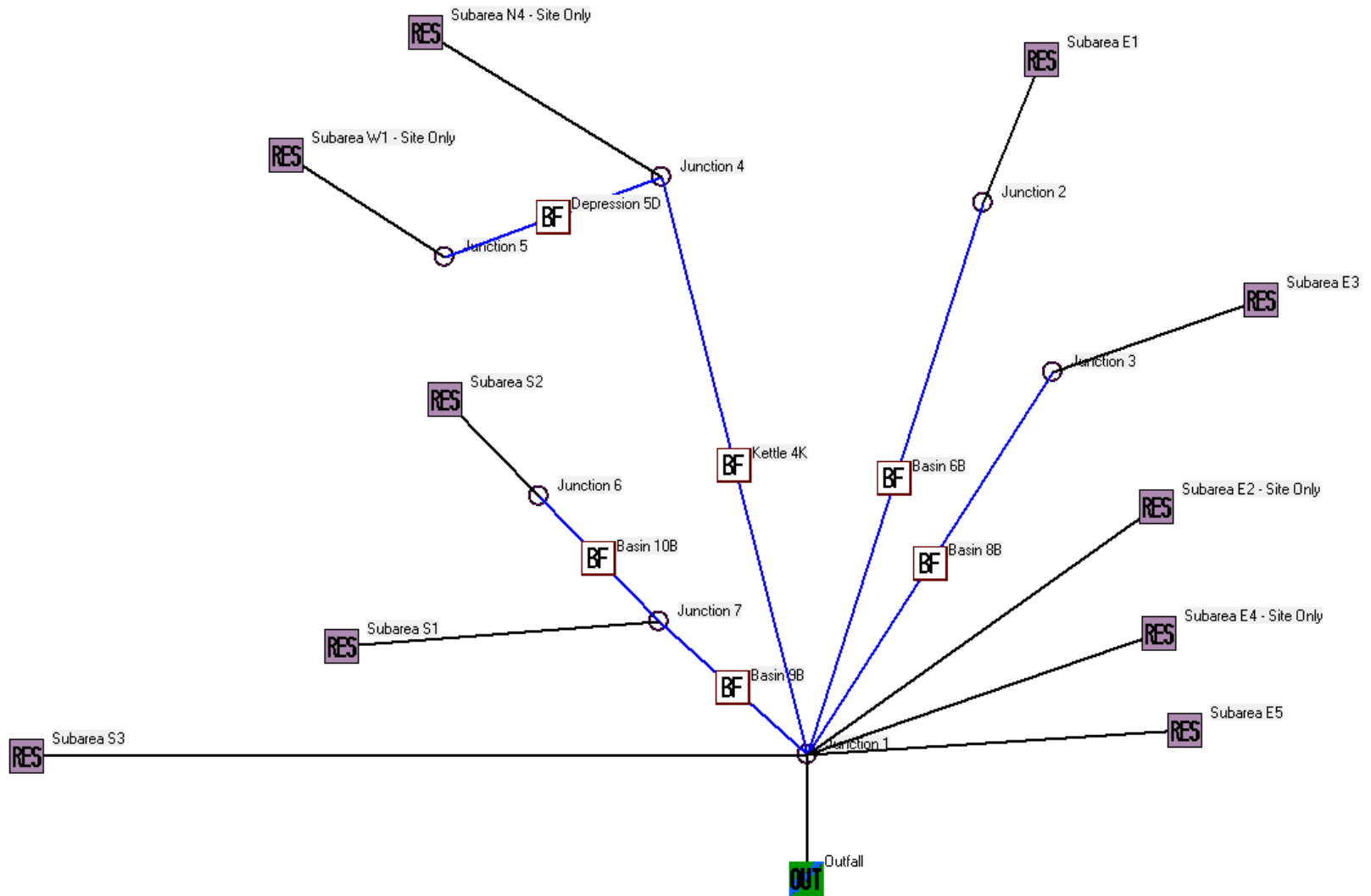

SLAMM for Windows Version 10.5.0
(c) Copyright Robert Pitt and John Voorhees 2019, All Rights Reserved

Data file name: C:\Data\Jobs\2026\2026-002 - Autumn Run - Town of Mukwanago - TRIO and Ryan\Project_Information\Calcs\SLAMM\Proposed_Connected.mdb
Data file description:
Rain file name: C:\WinSLAMM Files\Rain Files\WisReg - Milwaukee WI 1969.RAN
Particulate Solids Concentration file name: C:\WinSLAMM Files\v10.1 WI_AVG01.pscx
Runoff Coefficient file name: C:\WinSLAMM Files\WI_SL06 Dec06.rsvx
Pollutant Relative Concentration file name: C:\WinSLAMM Files\WI_GE003.ppdx
Residential Street Delivery file name: C:\WinSLAMM Files\WI_Res and Other Urban Dec06.std
Institutional Street Delivery file name: C:\WinSLAMM Files\WI_Com Inst Indust Dec06.std
Commercial Street Delivery file name: C:\WinSLAMM Files\WI_Com Inst Indust Dec06.std
Industrial Street Delivery file name: C:\WinSLAMM Files\WI_Com Inst Indust Dec06.std
Other Urban Street Delivery file name: C:\WinSLAMM Files\WI_Res and Other Urban Dec06.std
Freeway Street Delivery file name: C:\WinSLAMM Files\Freeway Dec06.std
Apply Street Delivery Files to Adjust the After Event Load Street Dirt Mass Balance: False
Source Area PSD and Peak to Average Flow Ratio File: C:\WinSLAMM Files\NURP Source Area PSD Files.csv
Cost Data file name:
If Other Device Pollutant Load Reduction Values = 1, Off-site Pollutant Loads are Removed from Pollutant Load % Reduction calculations
Seed for random number generator: -42
Start of Winter Season: 12/06 End of Winter Season: 03/28
Model Run Start Date: 01/05/69 Model Run End Date: 12/31/69
Date of run: 05-13-2026 Time of run: 10:51:02
Total Area Modeled (acres): 54.440
Years in Model Run: 0.99

	Runoff Volume (cu ft)	Percent Runoff Reduction	Particulate Solids Conc. (mg/L)	Particulate Solids Yield (lbs)	Percent Particulate Solids Reduction
Total of all Land Uses without Controls:	658760	-	124.0	5100	-
Outfall Total with Controls:	138344	79.00%	125.5	1084	78.75%
Annualized Total After Outfall Controls:	140266			1099	

Pollutant	Concentration - No Controls	Concentration - With Controls	Conc. Units	Pollutant Yield No Controls	Pollutant Yield With Controls	Pol. Yield Units	Percent Reduction
Particulate Solids	124.0	125.5	mg/L	5100	1084	lbs	78.75 %
Total Phosphorus	0.7017	0.6686	mg/L	28.86	5.775	lbs	79.99 %

Data file name: C:\Data\Jobs\2026\2026-002 - Autumn Run - Town of Mukwanago - TRI0 and Ryan\Project_Information\Calcs\SLAMM\Proposed_Connected.mdb
WinSLAMM Version 10.5.0

Rain file name: C:\WinSLAMM Files\Rain Files\WisReg - Milwaukee WI 1969.RAN

Particulate Solids Concentration file name: C:\WinSLAMM Files\v10.1 WI_AVG01.pscx

Runoff Coefficient file name: C:\WinSLAMM Files\WI_SL06 Dec06.rsvx

Residential Street Delivery file name: C:\WinSLAMM Files\WI_Res and Other Urban Dec06.std

Institutional Street Delivery file name: C:\WinSLAMM Files\WI_Com Inst Indust Dec06.std

Commercial Street Delivery file name: C:\WinSLAMM Files\WI_Com Inst Indust Dec06.std

Industrial Street Delivery file name: C:\WinSLAMM Files\WI_Com Inst Indust Dec06.std

Other Urban Street Delivery file name: C:\WinSLAMM Files\WI_Res and Other Urban Dec06.std

Freeway Street Delivery file name: C:\WinSLAMM Files\Freeway Dec06.std

Apply Street Delivery Files to Adjust the After Event Load Street Dirt Mass Balance: False

Pollutant Relative Concentration file name: C:\WinSLAMM Files\WI_GEO03.ppd

Source Area PSD and Peak to Average Flow Ratio File: C:\WinSLAMM Files\NURP Source Area PSD Files.csv

Cost Data file name:

If Other Device Pollutant Load Reduction Values = 1, Off-site Pollutant Loads are Removed from Pollutant Load % Reduction calculations

Seed for random number generator: -42

Study period starting date: 01/05/69 Study period ending date: 12/31/69

Start of Winter Season: 12/06 End of Winter Season: 03/28

Date: 05-13-2026 Time: 10:51:11

Site information:

LU# 1 - Residential: Subarea N4 - Site Only Total area (ac): 10.370

1 - Roofs 1: 0.080 ac. Pitched Connected Source Area PSD File: C:\WinSLAMM Files\NURP.cpz

31 - Sidewalks 1: 0.020 ac. Connected Source Area PSD File: C:\WinSLAMM Files\NURP.cpz

45 - Large Landscaped Areas 1: 3.310 ac. Normal Silty Source Area PSD File: C:\WinSLAMM Files\NURP.cpz

57 - Undeveloped Areas 1: 6.960 ac. Normal Silty Source Area PSD File: C:\WinSLAMM Files\NURP.cpz

LU# 2 - Residential: Subarea E1 Total area (ac): 12.900

1 - Roofs 1: 0.580 ac. Pitched Connected Source Area PSD File: C:\WinSLAMM Files\NURP.cpz

25 - Driveways 1: 0.310 ac. Connected Source Area PSD File: C:\WinSLAMM Files\NURP.cpz

31 - Sidewalks 1: 0.150 ac. Connected Source Area PSD File: C:\WinSLAMM Files\NURP.cpz

37 - Streets 1: 0.600 ac. Smooth Street Length = 0.1456 mi Street Width = 33.99725 ft Street Edges = 2

Default St. Dirt Accum. Annual Winter Load = 2500 lbs Source Area PSD File: C:\WinSLAMM Files\NURP.cpz GS-CP#7

45 - Large Landscaped Areas 1: 7.840 ac. Normal Silty Source Area PSD File: C:\WinSLAMM Files\NURP.cpz

57 - Undeveloped Areas 1: 3.420 ac. Normal Silty Source Area PSD File: C:\WinSLAMM Files\NURP.cpz

LU# 3 - Residential: Subarea E2 - Site Only Total area (ac): 2.780

45 - Large Landscaped Areas 1: 0.210 ac. Normal Silty Source Area PSD File: C:\WinSLAMM Files\NURP.cpz

57 - Undeveloped Areas 1: 2.570 ac. Normal Silty Source Area PSD File: C:\WinSLAMM Files\NURP.cpz

LU# 4 - Residential: Subarea E3 Total area (ac): 4.280

1 - Roofs 1: 0.170 ac. Pitched Connected Source Area PSD File: C:\WinSLAMM Files\NURP.cpz

25 - Driveways 1: 0.100 ac. Connected Source Area PSD File: C:\WinSLAMM Files\NURP.cpz

31 - Sidewalks 1: 0.040 ac. Connected Source Area PSD File: C:\WinSLAMM Files\NURP.cpz

37 - Streets 1: 0.350 ac. Smooth Street Length = 0.0849 mi Street Width = 34.0106 ft Street Edges = 2

Default St. Dirt Accum. Annual Winter Load = 2500 lbs Source Area PSD File: C:\WinSLAMM Files\NURP.cpz GS-CP#8

45 - Large Landscaped Areas 1: 2.960 ac. Normal Silty Source Area PSD File: C:\WinSLAMM Files\NURP.cpz

57 - Undeveloped Areas 1: 0.660 ac. Normal Silty Source Area PSD File: C:\WinSLAMM Files\NURP.cpz

LU# 5 - Residential: Subarea E4 - Site Only Total area (ac): 0.520

37 - Streets 1: 0.050 ac. Smooth Street Length = 0.0121 mi Street Width = 34.09091 ft Street Edges = 2

Default St. Dirt Accum. Annual Winter Load = 2500 lbs Source Area PSD File: C:\WinSLAMM Files\NURP.cpz

45 - Large Landscaped Areas 1: 0.070 ac. Normal Silty Source Area PSD File: C:\WinSLAMM Files\NURP.cpz
57 - Undeveloped Areas 1: 0.400 ac. Normal Silty Source Area PSD File: C:\WinSLAMM Files\NURP.cpz

LU# 6 - Residential: Subarea W1 - Site Only Total area (ac): 5.700
1 - Roofs 1: 0.060 ac. Pitched Connected Source Area PSD File: C:\WinSLAMM Files\NURP.cpz
31 - Sidewalks 1: 0.020 ac. Connected Source Area PSD File: C:\WinSLAMM Files\NURP.cpz
45 - Large Landscaped Areas 1: 3.230 ac. Normal Silty Source Area PSD File: C:\WinSLAMM Files\NURP.cpz
57 - Undeveloped Areas 1: 2.390 ac. Normal Silty Source Area PSD File: C:\WinSLAMM Files\NURP.cpz

LU# 7 - Residential: Subarea S1 Total area (ac): 11.340
1 - Roofs 1: 0.480 ac. Pitched Connected Source Area PSD File: C:\WinSLAMM Files\NURP.cpz
25 - Driveways 1: 0.170 ac. Connected Source Area PSD File: C:\WinSLAMM Files\NURP.cpz
31 - Sidewalks 1: 0.120 ac. Connected Source Area PSD File: C:\WinSLAMM Files\NURP.cpz
37 - Streets 1: 0.550 ac. Smooth Street Length = 0.1335 mi Street Width = 33.98877 ft Street Edges = 2
Default St. Dirt Accum. Annual Winter Load = 2500 lbs Source Area PSD File: C:\WinSLAMM Files\NURP.cpz GS-CP#9
45 - Large Landscaped Areas 1: 7.920 ac. Normal Silty Source Area PSD File: C:\WinSLAMM Files\NURP.cpz
57 - Undeveloped Areas 1: 2.100 ac. Normal Silty Source Area PSD File: C:\WinSLAMM Files\NURP.cpz

LU# 8 - Residential: Subarea S2 Total area (ac): 3.470
1 - Roofs 1: 0.040 ac. Pitched Connected Source Area PSD File: C:\WinSLAMM Files\NURP.cpz
31 - Sidewalks 1: 0.010 ac. Connected Source Area PSD File: C:\WinSLAMM Files\NURP.cpz
45 - Large Landscaped Areas 1: 2.340 ac. Normal Silty Source Area PSD File: C:\WinSLAMM Files\NURP.cpz
57 - Undeveloped Areas 1: 1.080 ac. Normal Silty Source Area PSD File: C:\WinSLAMM Files\NURP.cpz

LU# 9 - Residential: Subarea S3 Total area (ac): 1.950
37 - Streets 1: 0.210 ac. Smooth Street Length = 0.051 mi Street Width = 33.97059 ft Street Edges = 2
Default St. Dirt Accum. Annual Winter Load = 2500 lbs Source Area PSD File: C:\WinSLAMM Files\NURP.cpz
45 - Large Landscaped Areas 1: 0.290 ac. Normal Silty Source Area PSD File: C:\WinSLAMM Files\NURP.cpz
57 - Undeveloped Areas 1: 1.450 ac. Normal Silty Source Area PSD File: C:\WinSLAMM Files\NURP.cpz

LU# 10 - Residential: Subarea E5 Total area (ac): 1.130
37 - Streets 1: 0.380 ac. Smooth Street Length = 0.0922 mi Street Width = 34.00217 ft Street Edges = 2
Default St. Dirt Accum. Annual Winter Load = 2500 lbs Source Area PSD File: C:\WinSLAMM Files\NURP.cpz
45 - Large Landscaped Areas 1: 0.310 ac. Normal Silty Source Area PSD File: C:\WinSLAMM Files\NURP.cpz
57 - Undeveloped Areas 1: 0.440 ac. Normal Silty Source Area PSD File: C:\WinSLAMM Files\NURP.cpz

Control Practice 1: Biofilter CP# 1 (DS) - Kettle 4K

1. Top area (square feet) = 247504
2. Bottom area (square feet) = 100
3. Depth (ft): 10.2
4. Biofilter width (ft) - for Cost Purposes Only: 10
5. Infiltration rate (in/hr) = 0.5
6. Random infiltration rate generation? No
7. Infiltration rate fraction (side): 1
8. Infiltration rate fraction (bottom): 1
9. Depth of biofilter that is rock filled (ft) 0
10. Porosity of rock filled volume = 0
11. Engineered soil infiltration rate: 0
12. Engineered soil depth (ft) = 0
13. Engineered soil porosity = 0
14. Percent solids reduction due to flow through engineered soil = 0
15. Biofilter peak to average flow ratio = 3.8

17. Particle size distribution file: Not needed - calculated by program
18. Initial water surface elevation (ft): 0
 - Soil Data Soil Type Fraction in Eng. Soil
 - Biofilter Outlet/Discharge Characteristics:
 - Outlet type: Broad Crested Weir
 1. Weir crest length (ft): 10
 2. Weir crest width (ft): 10
 3. Height of datum to bottom of weir opening: 2
 - Outlet type: Surface Discharge Pipe
 1. Surface discharge pipe outlet diameter (ft): 1
 2. Pipe invert elevation above datum (ft): 0.25
 3. Number of surface pipe outlets: 1

Control Practice 4: Biofilter CP# 4 (DS) - Basin 8B

1. Top area (square feet) = 15369
2. Bottom area (square feet) = 3368
3. Depth (ft): 4
4. Biofilter width (ft) - for Cost Purposes Only: 10
5. Infiltration rate (in/hr) = 0.11
6. Random infiltration rate generation? No
7. Infiltration rate fraction (side): 1
8. Infiltration rate fraction (bottom): 1
9. Depth of biofilter that is rock filled (ft) 0
10. Porosity of rock filled volume = 0
11. Engineered soil infiltration rate: 0
12. Engineered soil depth (ft) = 0
13. Engineered soil porosity = 0
14. Percent solids reduction due to flow through engineered soil = 0
15. Biofilter peak to average flow ratio = 3.8
16. Number of biofiltration control devices = 1
17. Particle size distribution file: Not needed - calculated by program
18. Initial water surface elevation (ft): 0
 - Soil Data Soil Type Fraction in Eng. Soil
 - Biofilter Outlet/Discharge Characteristics:
 - Outlet type: Broad Crested Weir
 1. Weir crest length (ft): 10
 2. Weir crest width (ft): 10
 3. Height of datum to bottom of weir opening: 3
 - Outlet type: Surface Discharge Pipe
 1. Surface discharge pipe outlet diameter (ft): 0.67
 2. Pipe invert elevation above datum (ft): 0.25
 3. Number of surface pipe outlets: 1

Control Practice 5: Biofilter CP# 5 (DS) - Basin 9B

1. Top area (square feet) = 30363
2. Bottom area (square feet) = 21774
3. Depth (ft): 3
4. Biofilter width (ft) - for Cost Purposes Only: 10
5. Infiltration rate (in/hr) = 0.5
6. Random infiltration rate generation? No
7. Infiltration rate fraction (side): 1
8. Infiltration rate fraction (bottom): 1
9. Depth of biofilter that is rock filled (ft) 0

10. Porosity of rock filled volume = 0
11. Engineered soil infiltration rate: 0
12. Engineered soil depth (ft) = 0
13. Engineered soil porosity = 0
14. Percent solids reduction due to flow through engineered soil = 0
15. Biofilter peak to average flow ratio = 3.8
16. Number of biofiltration control devices = 1
17. Particle size distribution file: Not needed - calculated by program
18. Initial water surface elevation (ft): 0
 - Soil Data Soil Type Fraction in Eng. Soil
 - Biofilter Outlet/Discharge Characteristics:
 - Outlet type: Broad Crested Weir
 1. Weir crest length (ft): 10
 2. Weir crest width (ft): 10
 3. Height of datum to bottom of weir opening: 2
 - Outlet type: Vertical Stand Pipe
 1. Stand pipe diameter (ft): 3
 2. Stand pipe height above datum (ft): 1.75

Control Practice 6: Biofilter CP# 6 (DS) - Basin 10B

1. Top area (square feet) = 20066
2. Bottom area (square feet) = 12005
3. Depth (ft): 3
4. Biofilter width (ft) - for Cost Purposes Only: 10
5. Infiltration rate (in/hr) = 0.5
6. Random infiltration rate generation? No
7. Infiltration rate fraction (side): 1
8. Infiltration rate fraction (bottom): 1
9. Depth of biofilter that is rock filled (ft) 0
10. Porosity of rock filled volume = 0
11. Engineered soil infiltration rate: 0
12. Engineered soil depth (ft) = 0
13. Engineered soil porosity = 0
14. Percent solids reduction due to flow through engineered soil = 0
15. Biofilter peak to average flow ratio = 3.8
16. Number of biofiltration control devices = 1
17. Particle size distribution file: Not needed - calculated by program
18. Initial water surface elevation (ft): 0
 - Soil Data Soil Type Fraction in Eng. Soil
 - Biofilter Outlet/Discharge Characteristics:
 - Outlet type: Broad Crested Weir
 1. Weir crest length (ft): 10
 2. Weir crest width (ft): 10
 3. Height of datum to bottom of weir opening: 2
 - Outlet type: Surface Discharge Pipe
 1. Surface discharge pipe outlet diameter (ft): 1.25
 2. Pipe invert elevation above datum (ft): 0
 3. Number of surface pipe outlets: 1

Control Practice 7: Grass Swale CP# 1 (SA) - SA Device, LU# 2 ,SA# 37

Total drainage area (acres) = 0.600
 Fraction of drainage area served by swales (ac) = 1.00
 Swale density (ft/ac) = 2833.33

Total swale length (ft) = 1700
Average swale length to outlet (ft)= 170
Typical bottom width (ft) = 2.0
Typical swale side slope (_H:1V) = 4.0
Typical longitudinal slope (ft.H/ft.V) = 0.040
Swale retardance factor: C
Typical grass height (in) = 4.0
Swale dynamic infiltration rate (in/hr)= 0.250
Typical swale depth (ft) for cost analysis (optional) = 0.0
Particle size distribution file name: Not needed - calculated by program
Use total swale length instead of swale density for infiltration calculations: True

Control Practice 8: Grass Swale CP# 2 (SA) - SA Device, LU# 4 ,SA# 37

Total drainage area (acres)= 0.350
Fraction of drainage area served by swales (ac) = 1.00
Swale density (ft/ac) = 2357.14
Total swale length (ft) = 825
Average swale length to outlet (ft)= 275
Typical bottom width (ft) = 2.0
Typical swale side slope (_H:1V) = 4.0
Typical longitudinal slope (ft.H/ft.V) = 0.030
Swale retardance factor: C
Typical grass height (in) = 4.0
Swale dynamic infiltration rate (in/hr)= 0.250
Typical swale depth (ft) for cost analysis (optional) = 0.0
Particle size distribution file name: Not needed - calculated by program
Use total swale length instead of swale density for infiltration calculations: True

Control Practice 9: Grass Swale CP# 3 (SA) - SA Device, LU# 7 ,SA# 37

Total drainage area (acres)= 0.550
Fraction of drainage area served by swales (ac) = 1.00
Swale density (ft/ac) = 2754.55
Total swale length (ft) = 1515
Average swale length to outlet (ft)= 215
Typical bottom width (ft) = 2.0
Typical swale side slope (_H:1V) = 4.0
Typical longitudinal slope (ft.H/ft.V) = 0.030
Swale retardance factor: C
Typical grass height (in) = 4.0
Swale dynamic infiltration rate (in/hr)= 0.250
Typical swale depth (ft) for cost analysis (optional) = 0.0
Particle size distribution file name: Not needed - calculated by program
Use total swale length instead of swale density for infiltration calculations: True

Treatment Analysis Disconnected Model

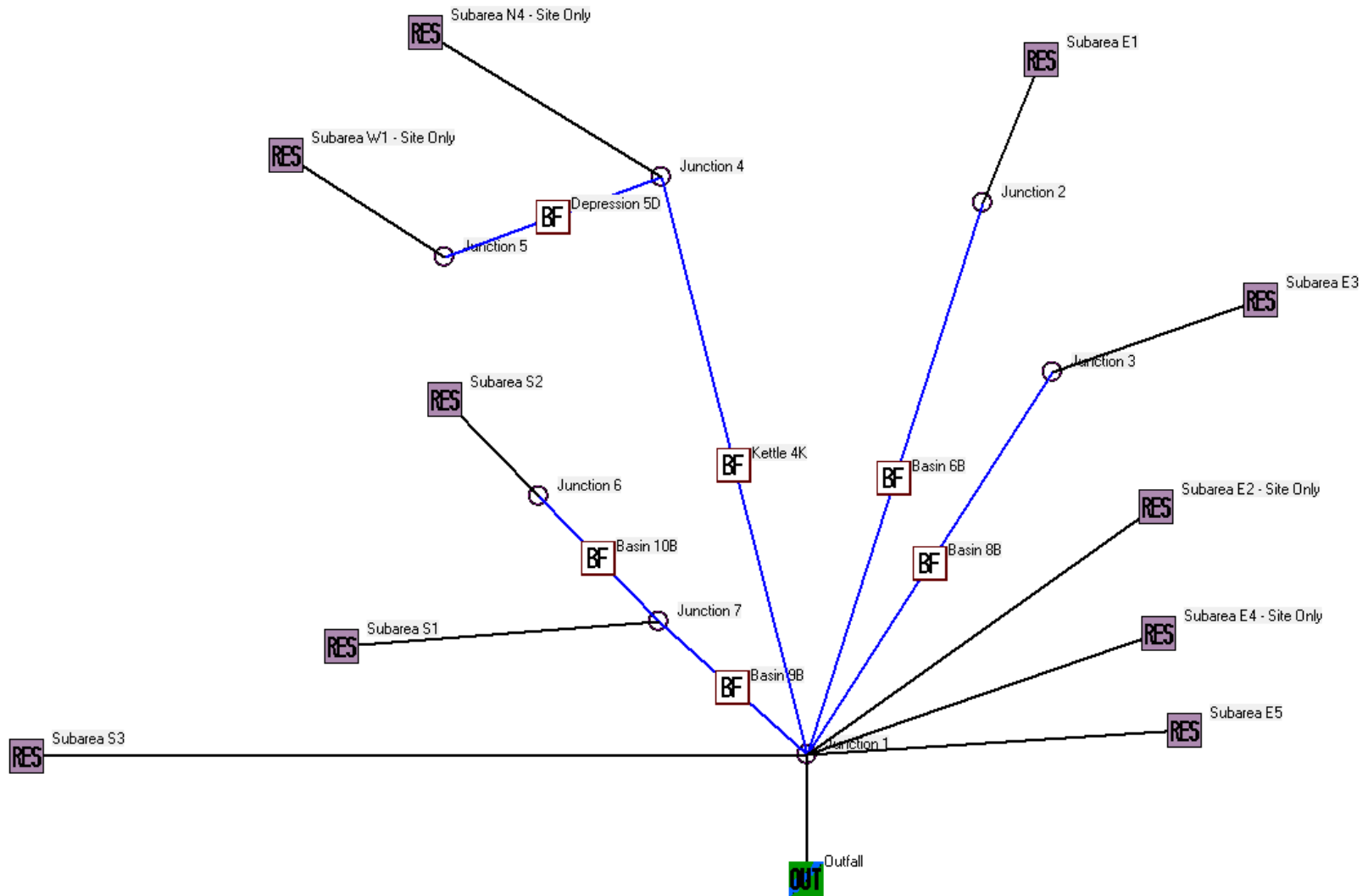

SLAMM for Windows Version 10.5.0
(c) Copyright Robert Pitt and John Voorhees 2019, All Rights Reserved

Data file name: C:\Data\Jobs\2026\2026-002 - Autumn Run - Town of Mukwanago - TRIO and Ryan\Project_Information\Calcs\SLAMM\Proposed_Disconnected.mdb
Data file description:
Rain file name: C:\WinSLAMM Files\Rain Files\WisReg - Milwaukee WI 1969.RAN
Particulate Solids Concentration file name: C:\WinSLAMM Files\v10.1 WI_AVG01.pscx
Runoff Coefficient file name: C:\WinSLAMM Files\WI_SL06 Dec06.rsvx
Pollutant Relative Concentration file name: C:\WinSLAMM Files\WI_GE003.ppdx
Residential Street Delivery file name: C:\WinSLAMM Files\WI_Res and Other Urban Dec06.std
Institutional Street Delivery file name: C:\WinSLAMM Files\WI_Com Inst Indust Dec06.std
Commercial Street Delivery file name: C:\WinSLAMM Files\WI_Com Inst Indust Dec06.std
Industrial Street Delivery file name: C:\WinSLAMM Files\WI_Com Inst Indust Dec06.std
Other Urban Street Delivery file name: C:\WinSLAMM Files\WI_Res and Other Urban Dec06.std
Freeway Street Delivery file name: C:\WinSLAMM Files\Freeway Dec06.std
Apply Street Delivery Files to Adjust the After Event Load Street Dirt Mass Balance: False
Source Area PSD and Peak to Average Flow Ratio File: C:\WinSLAMM Files\NURP Source Area PSD Files.csv
Cost Data file name:
If Other Device Pollutant Load Reduction Values = 1, Off-site Pollutant Loads are Removed from Pollutant Load % Reduction calculations
Seed for random number generator: -42
Start of Winter Season: 12/06 End of Winter Season: 03/28
Model Run Start Date: 01/05/69 Model Run End Date: 12/31/69
Date of run: 05-13-2026 Time of run: 10:41:12
Total Area Modeled (acres): 54.440
Years in Model Run: 0.99

	Runoff Volume (cu ft)	Percent Runoff Reduction	Particulate Solids Conc. (mg/L)	Particulate Solids Yield (lbs)	Percent Particulate Solids Reduction
Total of all Land Uses without Controls:	503789	-	148.8	4681	-
Outfall Total with Controls:	115882	77.00%	131.6	952.3	79.66%
Annualized Total After Outfall Controls:	117492			965.5	

Pollutant	Concentration - No Controls	Concentration - With Controls	Conc. Units	Pollutant Yield No Controls	Pollutant Yield With Controls	Pol. Yield Units	Percent Reduction
Particulate Solids	148.8	131.6	mg/L	4681	952.3	lbs	79.66 %
Total Phosphorus	0.8606	0.6934	mg/L	27.07	5.016	lbs	81.47 %

Data file name: C:\Data\Jobs\2026\2026-002 - Autumn Run - Town of Mukwanago - TRI0 and Ryan\Project_Information\Calcs\SLAMM\Proposed_Disconnected.mdb
WinSLAMM Version 10.5.0

Rain file name: C:\WinSLAMM Files\Rain Files\WisReg - Milwaukee WI 1969.RAN

Particulate Solids Concentration file name: C:\WinSLAMM Files\v10.1 WI_AVG01.pscx

Runoff Coefficient file name: C:\WinSLAMM Files\WI_SL06 Dec06.rsvx

Residential Street Delivery file name: C:\WinSLAMM Files\WI_Res and Other Urban Dec06.std

Institutional Street Delivery file name: C:\WinSLAMM Files\WI_Com Inst Indust Dec06.std

Commercial Street Delivery file name: C:\WinSLAMM Files\WI_Com Inst Indust Dec06.std

Industrial Street Delivery file name: C:\WinSLAMM Files\WI_Com Inst Indust Dec06.std

Other Urban Street Delivery file name: C:\WinSLAMM Files\WI_Res and Other Urban Dec06.std

Freeway Street Delivery file name: C:\WinSLAMM Files\Freeway Dec06.std

Apply Street Delivery Files to Adjust the After Event Load Street Dirt Mass Balance: False

Pollutant Relative Concentration file name: C:\WinSLAMM Files\WI_GEO03.ppdx

Source Area PSD and Peak to Average Flow Ratio File: C:\WinSLAMM Files\NURP Source Area PSD Files.csv

Cost Data file name:

If Other Device Pollutant Load Reduction Values = 1, Off-site Pollutant Loads are Removed from Pollutant Load % Reduction calculations

Seed for random number generator: -42

Study period starting date: 01/05/69 Study period ending date: 12/31/69

Start of Winter Season: 12/06 End of Winter Season: 03/28

Date: 05-13-2026

Time: 10:41:19

Site information:

LU# 1 - Residential: Subarea N4 - Site Only Total area (ac): 10.370

1 - Roofs 1: 0.080 ac. Pitched Disconnected Normal Silty Source Area PSD File: C:\WinSLAMM Files\NURP.cpz

31 - Sidewalks 1: 0.020 ac. Disconnected Normal Silty Source Area PSD File: C:\WinSLAMM Files\NURP.cpz

45 - Large Landscaped Areas 1: 3.310 ac. Normal Silty Source Area PSD File: C:\WinSLAMM Files\NURP.cpz

57 - Undeveloped Areas 1: 6.960 ac. Normal Silty Source Area PSD File: C:\WinSLAMM Files\NURP.cpz

LU# 2 - Residential: Subarea E1 Total area (ac): 12.900

1 - Roofs 1: 0.580 ac. Pitched Disconnected Normal Silty Source Area PSD File: C:\WinSLAMM Files\NURP.cpz

25 - Driveways 1: 0.310 ac. Connected Source Area PSD File: C:\WinSLAMM Files\NURP.cpz

31 - Sidewalks 1: 0.150 ac. Disconnected Normal Silty Source Area PSD File: C:\WinSLAMM Files\NURP.cpz

37 - Streets 1: 0.600 ac. Smooth Street Length = 0.1456 mi Street Width = 33.99725 ft Street Edges = 2

Default St. Dirt Accum. Annual Winter Load = 2500 lbs Source Area PSD File: C:\WinSLAMM Files\NURP.cpz GS-CP#7

45 - Large Landscaped Areas 1: 7.840 ac. Normal Silty Source Area PSD File: C:\WinSLAMM Files\NURP.cpz

57 - Undeveloped Areas 1: 3.420 ac. Normal Silty Source Area PSD File: C:\WinSLAMM Files\NURP.cpz

LU# 3 - Residential: Subarea E2 - Site Only Total area (ac): 2.780

45 - Large Landscaped Areas 1: 0.210 ac. Normal Silty Source Area PSD File: C:\WinSLAMM Files\NURP.cpz

57 - Undeveloped Areas 1: 2.570 ac. Normal Silty Source Area PSD File: C:\WinSLAMM Files\NURP.cpz

LU# 4 - Residential: Subarea E3 Total area (ac): 4.280

1 - Roofs 1: 0.170 ac. Pitched Disconnected Normal Silty Source Area PSD File: C:\WinSLAMM Files\NURP.cpz

25 - Driveways 1: 0.100 ac. Connected Source Area PSD File: C:\WinSLAMM Files\NURP.cpz

31 - Sidewalks 1: 0.040 ac. Disconnected Normal Silty Source Area PSD File: C:\WinSLAMM Files\NURP.cpz

37 - Streets 1: 0.350 ac. Smooth Street Length = 0.0849 mi Street Width = 34.0106 ft Street Edges = 2

Default St. Dirt Accum. Annual Winter Load = 2500 lbs Source Area PSD File: C:\WinSLAMM Files\NURP.cpz GS-CP#8

45 - Large Landscaped Areas 1: 2.960 ac. Normal Silty Source Area PSD File: C:\WinSLAMM Files\NURP.cpz

57 - Undeveloped Areas 1: 0.660 ac. Normal Silty Source Area PSD File: C:\WinSLAMM Files\NURP.cpz

LU# 5 - Residential: Subarea E4 - Site Only Total area (ac): 0.520

37 - Streets 1: 0.050 ac. Smooth Street Length = 0.0121 mi Street Width = 34.09091 ft Street Edges = 2

Default St. Dirt Accum. Annual Winter Load = 2500 lbs Source Area PSD File: C:\WinSLAMM Files\NURP.cpz

45 - Large Landscaped Areas 1: 0.070 ac. Normal Silty Source Area PSD File: C:\WinSLAMM Files\NURP.cpz
57 - Undeveloped Areas 1: 0.400 ac. Normal Silty Source Area PSD File: C:\WinSLAMM Files\NURP.cpz

LU# 6 - Residential: Subarea W1 - Site Only Total area (ac): 5.700
1 - Roofs 1: 0.060 ac. Pitched Disconnected Normal Silty Source Area PSD File: C:\WinSLAMM Files\NURP.cpz
31 - Sidewalks 1: 0.020 ac. Disconnected Normal Silty Source Area PSD File: C:\WinSLAMM Files\NURP.cpz
45 - Large Landscaped Areas 1: 3.230 ac. Normal Silty Source Area PSD File: C:\WinSLAMM Files\NURP.cpz
57 - Undeveloped Areas 1: 2.390 ac. Normal Silty Source Area PSD File: C:\WinSLAMM Files\NURP.cpz

LU# 7 - Residential: Subarea S1 Total area (ac): 11.340
1 - Roofs 1: 0.480 ac. Pitched Disconnected Normal Silty Source Area PSD File: C:\WinSLAMM Files\NURP.cpz
25 - Driveways 1: 0.170 ac. Connected Source Area PSD File: C:\WinSLAMM Files\NURP.cpz
31 - Sidewalks 1: 0.120 ac. Disconnected Normal Silty Source Area PSD File: C:\WinSLAMM Files\NURP.cpz
37 - Streets 1: 0.550 ac. Smooth Street Length = 0.1335 mi Street Width = 33.98877 ft Street Edges = 2
Default St. Dirt Accum. Annual Winter Load = 2500 lbs Source Area PSD File: C:\WinSLAMM Files\NURP.cpz GS-CP#9
45 - Large Landscaped Areas 1: 7.920 ac. Normal Silty Source Area PSD File: C:\WinSLAMM Files\NURP.cpz
57 - Undeveloped Areas 1: 2.100 ac. Normal Silty Source Area PSD File: C:\WinSLAMM Files\NURP.cpz

LU# 8 - Residential: Subarea S2 Total area (ac): 3.470
1 - Roofs 1: 0.040 ac. Pitched Disconnected Normal Silty Source Area PSD File: C:\WinSLAMM Files\NURP.cpz
31 - Sidewalks 1: 0.010 ac. Disconnected Normal Silty Source Area PSD File: C:\WinSLAMM Files\NURP.cpz
45 - Large Landscaped Areas 1: 2.340 ac. Normal Silty Source Area PSD File: C:\WinSLAMM Files\NURP.cpz
57 - Undeveloped Areas 1: 1.080 ac. Normal Silty Source Area PSD File: C:\WinSLAMM Files\NURP.cpz

LU# 9 - Residential: Subarea S3 Total area (ac): 1.950
37 - Streets 1: 0.210 ac. Smooth Street Length = 0.051 mi Street Width = 33.97059 ft Street Edges = 2
Default St. Dirt Accum. Annual Winter Load = 2500 lbs Source Area PSD File: C:\WinSLAMM Files\NURP.cpz
45 - Large Landscaped Areas 1: 0.290 ac. Normal Silty Source Area PSD File: C:\WinSLAMM Files\NURP.cpz
57 - Undeveloped Areas 1: 1.450 ac. Normal Silty Source Area PSD File: C:\WinSLAMM Files\NURP.cpz

LU# 10 - Residential: Subarea E5 Total area (ac): 1.130
37 - Streets 1: 0.380 ac. Smooth Street Length = 0.0922 mi Street Width = 34.00217 ft Street Edges = 2
Default St. Dirt Accum. Annual Winter Load = 2500 lbs Source Area PSD File: C:\WinSLAMM Files\NURP.cpz
45 - Large Landscaped Areas 1: 0.310 ac. Normal Silty Source Area PSD File: C:\WinSLAMM Files\NURP.cpz
57 - Undeveloped Areas 1: 0.440 ac. Normal Silty Source Area PSD File: C:\WinSLAMM Files\NURP.cpz

Control Practice 1: Biofilter CP# 1 (DS) - Kettle 4K

1. Top area (square feet) = 247504
2. Bottom area (square feet) = 100
3. Depth (ft): 10.2
4. Biofilter width (ft) - for Cost Purposes Only: 10
5. Infiltration rate (in/hr) = 0.5
6. Random infiltration rate generation? No
7. Infiltration rate fraction (side): 1
8. Infiltration rate fraction (bottom): 1
9. Depth of biofilter that is rock filled (ft) 0
10. Porosity of rock filled volume = 0
11. Engineered soil infiltration rate: 0
12. Engineered soil depth (ft) = 0
13. Engineered soil porosity = 0
14. Percent solids reduction due to flow through engineered soil = 0
15. Biofilter peak to average flow ratio = 3.8

17. Particle size distribution file: Not needed - calculated by program
18. Initial water surface elevation (ft): 0
 - Soil Data Soil Type Fraction in Eng. Soil
 - Biofilter Outlet/Discharge Characteristics:
 - Outlet type: Broad Crested Weir
 1. Weir crest length (ft): 10
 2. Weir crest width (ft): 10
 3. Height of datum to bottom of weir opening: 2
 - Outlet type: Surface Discharge Pipe
 1. Surface discharge pipe outlet diameter (ft): 1
 2. Pipe invert elevation above datum (ft): 0.25
 3. Number of surface pipe outlets: 1

Control Practice 4: Biofilter CP# 4 (DS) - Basin 8B

1. Top area (square feet) = 15369
2. Bottom area (square feet) = 3368
3. Depth (ft): 4
4. Biofilter width (ft) - for Cost Purposes Only: 10
5. Infiltration rate (in/hr) = 0.11
6. Random infiltration rate generation? No
7. Infiltration rate fraction (side): 1
8. Infiltration rate fraction (bottom): 1
9. Depth of biofilter that is rock filled (ft) 0
10. Porosity of rock filled volume = 0
11. Engineered soil infiltration rate: 0
12. Engineered soil depth (ft) = 0
13. Engineered soil porosity = 0
14. Percent solids reduction due to flow through engineered soil = 0
15. Biofilter peak to average flow ratio = 3.8
16. Number of biofiltration control devices = 1
17. Particle size distribution file: Not needed - calculated by program
18. Initial water surface elevation (ft): 0
 - Soil Data Soil Type Fraction in Eng. Soil
 - Biofilter Outlet/Discharge Characteristics:
 - Outlet type: Broad Crested Weir
 1. Weir crest length (ft): 10
 2. Weir crest width (ft): 10
 3. Height of datum to bottom of weir opening: 3
 - Outlet type: Surface Discharge Pipe
 1. Surface discharge pipe outlet diameter (ft): 0.67
 2. Pipe invert elevation above datum (ft): 0.25
 3. Number of surface pipe outlets: 1

Control Practice 5: Biofilter CP# 5 (DS) - Basin 9B

1. Top area (square feet) = 30363
2. Bottom area (square feet) = 21774
3. Depth (ft): 3
4. Biofilter width (ft) - for Cost Purposes Only: 10
5. Infiltration rate (in/hr) = 0.5
6. Random infiltration rate generation? No
7. Infiltration rate fraction (side): 1
8. Infiltration rate fraction (bottom): 1
9. Depth of biofilter that is rock filled (ft) 0

10. Porosity of rock filled volume = 0
11. Engineered soil infiltration rate: 0
12. Engineered soil depth (ft) = 0
13. Engineered soil porosity = 0
14. Percent solids reduction due to flow through engineered soil = 0
15. Biofilter peak to average flow ratio = 3.8
16. Number of biofiltration control devices = 1
17. Particle size distribution file: Not needed - calculated by program
18. Initial water surface elevation (ft): 0
 - Soil Data Soil Type Fraction in Eng. Soil
 - Biofilter Outlet/Discharge Characteristics:
 - Outlet type: Broad Crested Weir
 1. Weir crest length (ft): 10
 2. Weir crest width (ft): 10
 3. Height of datum to bottom of weir opening: 2
 - Outlet type: Vertical Stand Pipe
 1. Stand pipe diameter (ft): 3
 2. Stand pipe height above datum (ft): 1.75

Control Practice 6: Biofilter CP# 6 (DS) - Basin 10B

1. Top area (square feet) = 20066
2. Bottom area (square feet) = 12005
3. Depth (ft): 3
4. Biofilter width (ft) - for Cost Purposes Only: 10
5. Infiltration rate (in/hr) = 0.5
6. Random infiltration rate generation? No
7. Infiltration rate fraction (side): 1
8. Infiltration rate fraction (bottom): 1
9. Depth of biofilter that is rock filled (ft) 0
10. Porosity of rock filled volume = 0
11. Engineered soil infiltration rate: 0
12. Engineered soil depth (ft) = 0
13. Engineered soil porosity = 0
14. Percent solids reduction due to flow through engineered soil = 0
15. Biofilter peak to average flow ratio = 3.8
16. Number of biofiltration control devices = 1
17. Particle size distribution file: Not needed - calculated by program
18. Initial water surface elevation (ft): 0
 - Soil Data Soil Type Fraction in Eng. Soil
 - Biofilter Outlet/Discharge Characteristics:
 - Outlet type: Broad Crested Weir
 1. Weir crest length (ft): 10
 2. Weir crest width (ft): 10
 3. Height of datum to bottom of weir opening: 2
 - Outlet type: Surface Discharge Pipe
 1. Surface discharge pipe outlet diameter (ft): 1.25
 2. Pipe invert elevation above datum (ft): 0
 3. Number of surface pipe outlets: 1

Control Practice 7: Grass Swale CP# 1 (SA) - SA Device, LU# 2 ,SA# 37

Total drainage area (acres)= 0.600
 Fraction of drainage area served by swales (ac) = 1.00
 Swale density (ft/ac) = 2833.33

Total swale length (ft) = 1700
Average swale length to outlet (ft)= 170
Typical bottom width (ft) = 2.0
Typical swale side slope (_H:1V) = 4.0
Typical longitudinal slope (ft.H/ft.V) = 0.040
Swale retardance factor: C
Typical grass height (in) = 4.0
Swale dynamic infiltration rate (in/hr)= 0.250
Typical swale depth (ft) for cost analysis (optional) = 0.0
Particle size distribution file name: Not needed - calculated by program
Use total swale length instead of swale density for infiltration calculations: True

Control Practice 8: Grass Swale CP# 2 (SA) - SA Device, LU# 4 ,SA# 37

Total drainage area (acres)= 0.350
Fraction of drainage area served by swales (ac) = 1.00
Swale density (ft/ac) = 2357.14
Total swale length (ft) = 825
Average swale length to outlet (ft)= 275
Typical bottom width (ft) = 2.0
Typical swale side slope (_H:1V) = 4.0
Typical longitudinal slope (ft.H/ft.V) = 0.030
Swale retardance factor: C
Typical grass height (in) = 4.0
Swale dynamic infiltration rate (in/hr)= 0.250
Typical swale depth (ft) for cost analysis (optional) = 0.0
Particle size distribution file name: Not needed - calculated by program
Use total swale length instead of swale density for infiltration calculations: True

Control Practice 9: Grass Swale CP# 3 (SA) - SA Device, LU# 7 ,SA# 37

Total drainage area (acres)= 0.550
Fraction of drainage area served by swales (ac) = 1.00
Swale density (ft/ac) = 2754.55
Total swale length (ft) = 1515
Average swale length to outlet (ft)= 215
Typical bottom width (ft) = 2.0
Typical swale side slope (_H:1V) = 4.0
Typical longitudinal slope (ft.H/ft.V) = 0.030
Swale retardance factor: C
Typical grass height (in) = 4.0
Swale dynamic infiltration rate (in/hr)= 0.250
Typical swale depth (ft) for cost analysis (optional) = 0.0
Particle size distribution file name: Not needed - calculated by program
Use total swale length instead of swale density for infiltration calculations: True

APPENDIX D

Infiltration Analysis / WinSLAMM

Infiltration Analysis Results

FOR: Autumn Run

LOCATION: Town of Mukwonago, Wisconsin

Pre-Development			
Project Site	54.44	acres =	2,371,406 sq-ft
Average Annual Rainfall	29.02	inches =	2.42 feet
Total Rainfall Volume	5,734,851	cu-ft	
Total Runoff (from SLAMM Output)	183,426	cu-ft	
Total Pre-Development Infiltration Volume	5,551,425	cu-ft	

Post-Development			
Project Site	54.44	acres =	2,371,406 sq-ft
Average Annual Rainfall	29.02	inches =	2.42 feet
Total Rainfall Volume	5,734,851	cu-ft	
Total Runoff (from SLAMM Output)	115,882	cu-ft	
Total Post-Development Infiltration Volume	5,618,969	cu-ft	

Percent Infiltrated	
Post Infiltration Vol / Pre Infiltration Vol	101.2%

Infiltration Analysis Existing Conditions

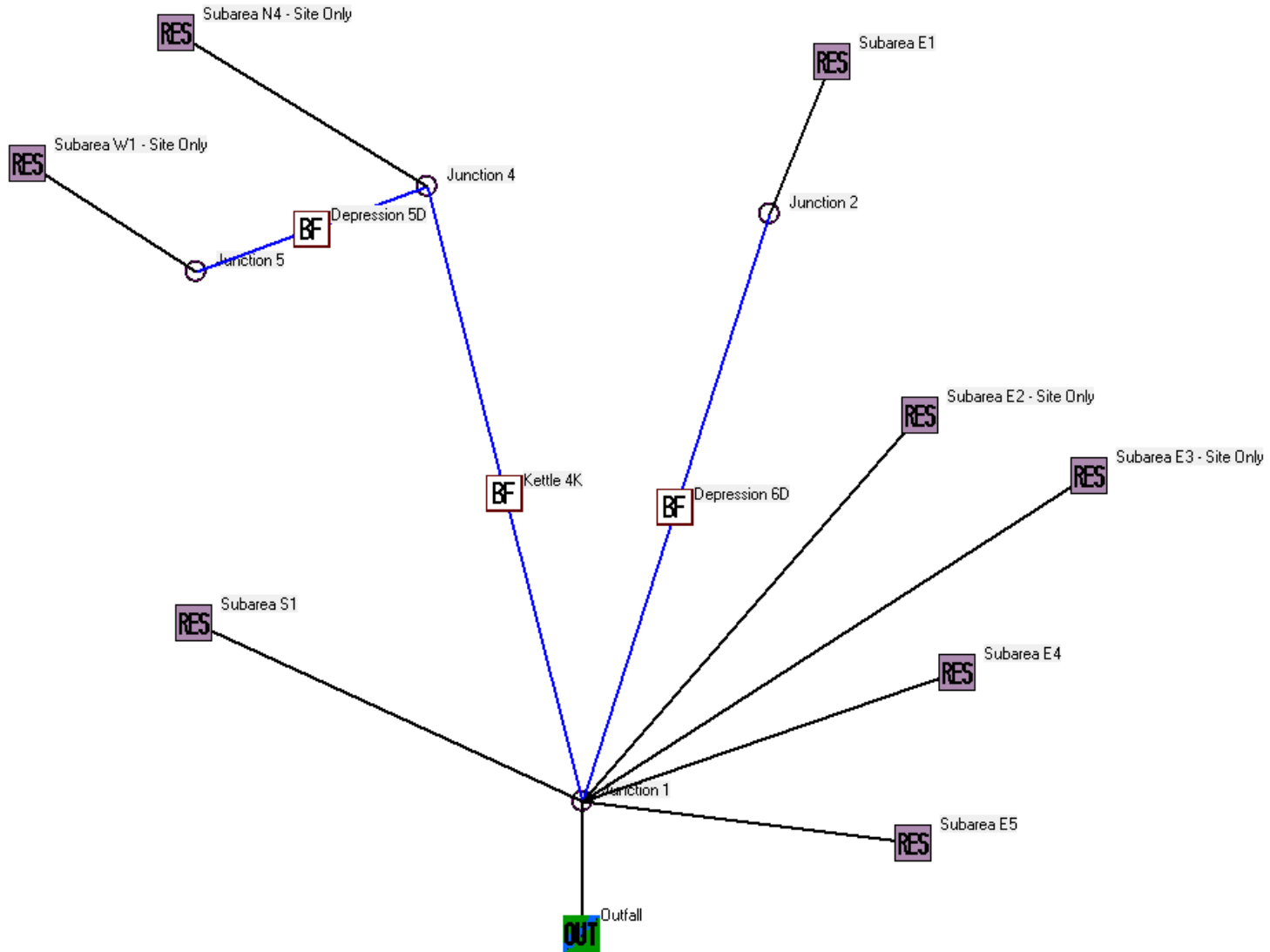

SLAMM for Windows Version 10.5.0
(c) Copyright Robert Pitt and John Voorhees 2019, All Rights Reserved

Data file name: C:\Data\Jobs\2026\2026-002 - Autumn Run - Town of Mukwanago - TRIO and Ryan\Project_Information\Calcs\SLAMM\Existing.mdb

Data file description:

Rain file name: C:\WinSLAMM Files\Rain Files\WisReg - Milwaukee WI 1969.RAN
Particulate Solids Concentration file name: C:\WinSLAMM Files\v10.1 WI_AVG01.pscx
Runoff Coefficient file name: C:\WinSLAMM Files\WI_SL06 Dec06.rsvx
Pollutant Relative Concentration file name: C:\WinSLAMM Files\WI_GE003.ppd
Residential Street Delivery file name: C:\WinSLAMM Files\WI_Res and Other Urban Dec06.std
Institutional Street Delivery file name: C:\WinSLAMM Files\WI_Com Inst Indust Dec06.std
Commercial Street Delivery file name: C:\WinSLAMM Files\WI_Com Inst Indust Dec06.std
Industrial Street Delivery file name: C:\WinSLAMM Files\WI_Com Inst Indust Dec06.std
Other Urban Street Delivery file name: C:\WinSLAMM Files\WI_Res and Other Urban Dec06.std
Freeway Street Delivery file name: C:\WinSLAMM Files\Freeway Dec06.std
Apply Street Delivery Files to Adjust the After Event Load Street Dirt Mass Balance: False
Source Area PSD and Peak to Average Flow Ratio File: C:\WinSLAMM Files\NURP Source Area PSD Files.csv
Cost Data file name:

If Other Device Pollutant Load Reduction Values = 1, Off-site Pollutant Loads are Removed from Pollutant Load % Reduction calculations

Seed for random number generator: -42

Start of Winter Season: 12/06 End of Winter Season: 03/28

Model Run Start Date: 01/05/69 Model Run End Date: 12/31/69

Date of run: 05-12-2026 Time of run: 23:14:04

Total Area Modeled (acres): 54.440

Years in Model Run: 0.99

	Runoff Volume (cu ft)	Percent Runoff Reduction	Particulate Solids Conc. (mg/L)	Particulate Solids Yield (lbs)	Percent Particulate Solids Reduction
Total of all Land Uses without Controls:	346644	-	203.5	4403	-
Outfall Total with Controls:	183426	47.09%	212.6	2435	44.70%
Annualized Total After Outfall Controls:	185974			2469	

Pollutant	Concentration - No Controls	Concentration - With Controls	Conc. Units	Pollutant Yield No Controls	Pollutant Yield With Controls	Pol. Yield Units	Percent Reduction
Particulate Solids	203.5	212.6	mg/L	4403	2435	lbs	44.70 %
Total Phosphorus	1.392	1.410	mg/L	30.12	16.14	lbs	46.41 %

Data file name: C:\Data\Jobs\2026\2026-002 - Autumn Run - Town of Mukwanago - TRI0 and Ryan\Project_Information\Calcs\SLAMM\Existing.mdb
WinSLAMM Version 10.5.0

Rain file name: C:\WinSLAMM Files\Rain Files\WisReg - Milwaukee WI 1969.RAN

Particulate Solids Concentration file name: C:\WinSLAMM Files\v10.1 WI_AVG01.pscx

Runoff Coefficient file name: C:\WinSLAMM Files\WI_SL06 Dec06.rsvx

Residential Street Delivery file name: C:\WinSLAMM Files\WI_Res and Other Urban Dec06.std

Institutional Street Delivery file name: C:\WinSLAMM Files\WI_Com Inst Indust Dec06.std

Commercial Street Delivery file name: C:\WinSLAMM Files\WI_Com Inst Indust Dec06.std

Industrial Street Delivery file name: C:\WinSLAMM Files\WI_Com Inst Indust Dec06.std

Other Urban Street Delivery file name: C:\WinSLAMM Files\WI_Res and Other Urban Dec06.std

Freeway Street Delivery file name: C:\WinSLAMM Files\Freeway Dec06.std

Apply Street Delivery Files to Adjust the After Event Load Street Dirt Mass Balance: False

Pollutant Relative Concentration file name: C:\WinSLAMM Files\WI_GEO03.ppd

Source Area PSD and Peak to Average Flow Ratio File: C:\WinSLAMM Files\NURP Source Area PSD Files.csv

Cost Data file name:

If Other Device Pollutant Load Reduction Values = 1, Off-site Pollutant Loads are Removed from Pollutant Load % Reduction calculations

Seed for random number generator: -42

Study period starting date: 01/05/69 Study period ending date: 12/31/69

Start of Winter Season: 12/06 End of Winter Season: 03/28

Date: 05-12-2026

Time: 23:14:12

Site information:

LU# 1 - Residential: Subarea N4 - Site Only Total area (ac): 10.550
45 - Large Landscaped Areas 1: 10.550 ac. Normal Silty Source Area PSD File: C:\WinSLAMM Files\NURP.cpz

LU# 2 - Residential: Subarea E1 Total area (ac): 6.320
1 - Roofs 1: 0.300 ac. Pitched Connected Source Area PSD File: C:\WinSLAMM Files\NURP.cpz
45 - Large Landscaped Areas 1: 6.020 ac. Normal Silty Source Area PSD File: C:\WinSLAMM Files\NURP.cpz

LU# 3 - Residential: Subarea E2 - Site Only Total area (ac): 5.930
45 - Large Landscaped Areas 1: 5.930 ac. Normal Silty Source Area PSD File: C:\WinSLAMM Files\NURP.cpz

LU# 4 - Residential: Subarea E3 - Site Only Total area (ac): 4.590
25 - Driveways 1: 0.270 ac. Connected Source Area PSD File: C:\WinSLAMM Files\NURP.cpz
45 - Large Landscaped Areas 1: 4.320 ac. Normal Silty Source Area PSD File: C:\WinSLAMM Files\NURP.cpz

LU# 5 - Residential: Subarea E4 Total area (ac): 1.600
25 - Driveways 1: 0.080 ac. Connected Source Area PSD File: C:\WinSLAMM Files\NURP.cpz
45 - Large Landscaped Areas 1: 1.520 ac. Normal Silty Source Area PSD File: C:\WinSLAMM Files\NURP.cpz

LU# 6 - Residential: Subarea W1 - Site Only Total area (ac): 9.010
45 - Large Landscaped Areas 1: 9.010 ac. Normal Silty Source Area PSD File: C:\WinSLAMM Files\NURP.cpz

LU# 7 - Residential: Subarea S1 Total area (ac): 15.500
25 - Driveways 1: 0.120 ac. Connected Source Area PSD File: C:\WinSLAMM Files\NURP.cpz
45 - Large Landscaped Areas 1: 15.380 ac. Normal Silty Source Area PSD File: C:\WinSLAMM Files\NURP.cpz

LU# 8 - Residential: Subarea E5 Total area (ac): 0.940
45 - Large Landscaped Areas 1: 0.940 ac. Normal Silty Source Area PSD File: C:\WinSLAMM Files\NURP.cpz

Control Practice 1: Biofilter CP# 1 (DS) - Kettle 4K

1. Top area (square feet) = 247504

Infiltration Analysis Proposed Disconnected Model

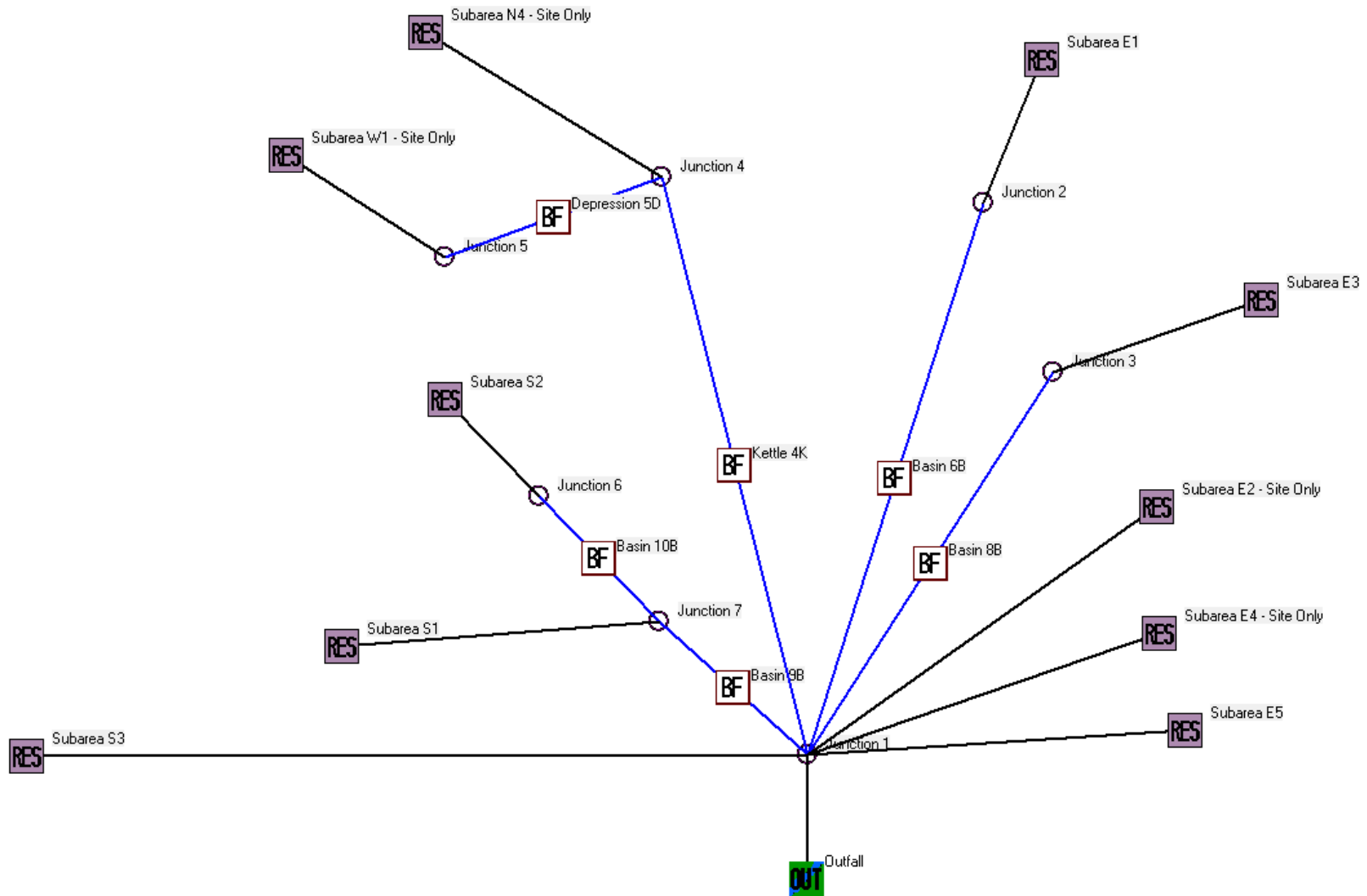

SLAMM for Windows Version 10.5.0
(c) Copyright Robert Pitt and John Voorhees 2019, All Rights Reserved

Data file name: C:\Data\Jobs\2026\2026-002 - Autumn Run - Town of Mukwanago - TRIO and Ryan\Project_Information\Calcs\SLAMM\Proposed_Disconnected.mdb
Data file description:
Rain file name: C:\WinSLAMM Files\Rain Files\WisReg - Milwaukee WI 1969.RAN
Particulate Solids Concentration file name: C:\WinSLAMM Files\v10.1 WI_AVG01.pscx
Runoff Coefficient file name: C:\WinSLAMM Files\WI_SL06 Dec06.rsvx
Pollutant Relative Concentration file name: C:\WinSLAMM Files\WI_GE003.ppdx
Residential Street Delivery file name: C:\WinSLAMM Files\WI_Res and Other Urban Dec06.std
Institutional Street Delivery file name: C:\WinSLAMM Files\WI_Com Inst Indust Dec06.std
Commercial Street Delivery file name: C:\WinSLAMM Files\WI_Com Inst Indust Dec06.std
Industrial Street Delivery file name: C:\WinSLAMM Files\WI_Com Inst Indust Dec06.std
Other Urban Street Delivery file name: C:\WinSLAMM Files\WI_Res and Other Urban Dec06.std
Freeway Street Delivery file name: C:\WinSLAMM Files\Freeway Dec06.std
Apply Street Delivery Files to Adjust the After Event Load Street Dirt Mass Balance: False
Source Area PSD and Peak to Average Flow Ratio File: C:\WinSLAMM Files\NURP Source Area PSD Files.csv
Cost Data file name:
If Other Device Pollutant Load Reduction Values = 1, Off-site Pollutant Loads are Removed from Pollutant Load % Reduction calculations
Seed for random number generator: -42
Start of Winter Season: 12/06 End of Winter Season: 03/28
Model Run Start Date: 01/05/69 Model Run End Date: 12/31/69
Date of run: 05-13-2026 Time of run: 10:41:12
Total Area Modeled (acres): 54.440
Years in Model Run: 0.99

	Runoff Volume (cu ft)	Percent Runoff Reduction	Particulate Solids Conc. (mg/L)	Particulate Solids Yield (lbs)	Percent Particulate Solids Reduction
Total of all Land Uses without Controls:	503789	-	148.8	4681	-
Outfall Total with Controls:	115882	77.00%	131.6	952.3	79.66%
Annualized Total After Outfall Controls:	117492			965.5	

Pollutant	Concentration - No Controls	Concentration - With Controls	Conc. Units	Pollutant Yield No Controls	Pollutant Yield With Controls	Pol. Yield Units	Percent Reduction
Particulate Solids	148.8	131.6	mg/L	4681	952.3	lbs	79.66 %
Total Phosphorus	0.8606	0.6934	mg/L	27.07	5.016	lbs	81.47 %

Data file name: C:\Data\Jobs\2026\2026-002 - Autumn Run - Town of Mukwanago - TRI0 and Ryan\Project_Information\Calcs\SLAMM\Proposed_Disconnected.mdb
WinSLAMM Version 10.5.0

Rain file name: C:\WinSLAMM Files\Rain Files\WisReg - Milwaukee WI 1969.RAN

Particulate Solids Concentration file name: C:\WinSLAMM Files\v10.1 WI_AVG01.pscx

Runoff Coefficient file name: C:\WinSLAMM Files\WI_SL06 Dec06.rsvx

Residential Street Delivery file name: C:\WinSLAMM Files\WI_Res and Other Urban Dec06.std

Institutional Street Delivery file name: C:\WinSLAMM Files\WI_Com Inst Indust Dec06.std

Commercial Street Delivery file name: C:\WinSLAMM Files\WI_Com Inst Indust Dec06.std

Industrial Street Delivery file name: C:\WinSLAMM Files\WI_Com Inst Indust Dec06.std

Other Urban Street Delivery file name: C:\WinSLAMM Files\WI_Res and Other Urban Dec06.std

Freeway Street Delivery file name: C:\WinSLAMM Files\Freeway Dec06.std

Apply Street Delivery Files to Adjust the After Event Load Street Dirt Mass Balance: False

Pollutant Relative Concentration file name: C:\WinSLAMM Files\WI_GEO03.ppx

Source Area PSD and Peak to Average Flow Ratio File: C:\WinSLAMM Files\NURP Source Area PSD Files.csv

Cost Data file name:

If Other Device Pollutant Load Reduction Values = 1, Off-site Pollutant Loads are Removed from Pollutant Load % Reduction calculations

Seed for random number generator: -42

Study period starting date: 01/05/69 Study period ending date: 12/31/69

Start of Winter Season: 12/06 End of Winter Season: 03/28

Date: 05-13-2026 Time: 10:41:19

Site information:

LU# 1 - Residential: Subarea N4 - Site Only Total area (ac): 10.370

1 - Roofs 1: 0.080 ac. Pitched Disconnected Normal Silty Source Area PSD File: C:\WinSLAMM Files\NURP.cpz

31 - Sidewalks 1: 0.020 ac. Disconnected Normal Silty Source Area PSD File: C:\WinSLAMM Files\NURP.cpz

45 - Large Landscaped Areas 1: 3.310 ac. Normal Silty Source Area PSD File: C:\WinSLAMM Files\NURP.cpz

57 - Undeveloped Areas 1: 6.960 ac. Normal Silty Source Area PSD File: C:\WinSLAMM Files\NURP.cpz

LU# 2 - Residential: Subarea E1 Total area (ac): 12.900

1 - Roofs 1: 0.580 ac. Pitched Disconnected Normal Silty Source Area PSD File: C:\WinSLAMM Files\NURP.cpz

25 - Driveways 1: 0.310 ac. Connected Source Area PSD File: C:\WinSLAMM Files\NURP.cpz

31 - Sidewalks 1: 0.150 ac. Disconnected Normal Silty Source Area PSD File: C:\WinSLAMM Files\NURP.cpz

37 - Streets 1: 0.600 ac. Smooth Street Length = 0.1456 mi Street Width = 33.99725 ft Street Edges = 2

Default St. Dirt Accum. Annual Winter Load = 2500 lbs Source Area PSD File: C:\WinSLAMM Files\NURP.cpz GS-CP#7

45 - Large Landscaped Areas 1: 7.840 ac. Normal Silty Source Area PSD File: C:\WinSLAMM Files\NURP.cpz

57 - Undeveloped Areas 1: 3.420 ac. Normal Silty Source Area PSD File: C:\WinSLAMM Files\NURP.cpz

LU# 3 - Residential: Subarea E2 - Site Only Total area (ac): 2.780

45 - Large Landscaped Areas 1: 0.210 ac. Normal Silty Source Area PSD File: C:\WinSLAMM Files\NURP.cpz

57 - Undeveloped Areas 1: 2.570 ac. Normal Silty Source Area PSD File: C:\WinSLAMM Files\NURP.cpz

LU# 4 - Residential: Subarea E3 Total area (ac): 4.280

1 - Roofs 1: 0.170 ac. Pitched Disconnected Normal Silty Source Area PSD File: C:\WinSLAMM Files\NURP.cpz

25 - Driveways 1: 0.100 ac. Connected Source Area PSD File: C:\WinSLAMM Files\NURP.cpz

31 - Sidewalks 1: 0.040 ac. Disconnected Normal Silty Source Area PSD File: C:\WinSLAMM Files\NURP.cpz

37 - Streets 1: 0.350 ac. Smooth Street Length = 0.0849 mi Street Width = 34.0106 ft Street Edges = 2

Default St. Dirt Accum. Annual Winter Load = 2500 lbs Source Area PSD File: C:\WinSLAMM Files\NURP.cpz GS-CP#8

45 - Large Landscaped Areas 1: 2.960 ac. Normal Silty Source Area PSD File: C:\WinSLAMM Files\NURP.cpz

57 - Undeveloped Areas 1: 0.660 ac. Normal Silty Source Area PSD File: C:\WinSLAMM Files\NURP.cpz

LU# 5 - Residential: Subarea E4 - Site Only Total area (ac): 0.520

37 - Streets 1: 0.050 ac. Smooth Street Length = 0.0121 mi Street Width = 34.09091 ft Street Edges = 2

Default St. Dirt Accum. Annual Winter Load = 2500 lbs Source Area PSD File: C:\WinSLAMM Files\NURP.cpz

45 - Large Landscaped Areas 1: 0.070 ac. Normal Silty Source Area PSD File: C:\WinSLAMM Files\NURP.cpz
57 - Undeveloped Areas 1: 0.400 ac. Normal Silty Source Area PSD File: C:\WinSLAMM Files\NURP.cpz

LU# 6 - Residential: Subarea W1 - Site Only Total area (ac): 5.700
1 - Roofs 1: 0.060 ac. Pitched Disconnected Normal Silty Source Area PSD File: C:\WinSLAMM Files\NURP.cpz
31 - Sidewalks 1: 0.020 ac. Disconnected Normal Silty Source Area PSD File: C:\WinSLAMM Files\NURP.cpz
45 - Large Landscaped Areas 1: 3.230 ac. Normal Silty Source Area PSD File: C:\WinSLAMM Files\NURP.cpz
57 - Undeveloped Areas 1: 2.390 ac. Normal Silty Source Area PSD File: C:\WinSLAMM Files\NURP.cpz

LU# 7 - Residential: Subarea S1 Total area (ac): 11.340
1 - Roofs 1: 0.480 ac. Pitched Disconnected Normal Silty Source Area PSD File: C:\WinSLAMM Files\NURP.cpz
25 - Driveways 1: 0.170 ac. Connected Source Area PSD File: C:\WinSLAMM Files\NURP.cpz
31 - Sidewalks 1: 0.120 ac. Disconnected Normal Silty Source Area PSD File: C:\WinSLAMM Files\NURP.cpz
37 - Streets 1: 0.550 ac. Smooth Street Length = 0.1335 mi Street Width = 33.98877 ft Street Edges = 2
Default St. Dirt Accum. Annual Winter Load = 2500 lbs Source Area PSD File: C:\WinSLAMM Files\NURP.cpz GS-CP#9
45 - Large Landscaped Areas 1: 7.920 ac. Normal Silty Source Area PSD File: C:\WinSLAMM Files\NURP.cpz
57 - Undeveloped Areas 1: 2.100 ac. Normal Silty Source Area PSD File: C:\WinSLAMM Files\NURP.cpz

LU# 8 - Residential: Subarea S2 Total area (ac): 3.470
1 - Roofs 1: 0.040 ac. Pitched Disconnected Normal Silty Source Area PSD File: C:\WinSLAMM Files\NURP.cpz
31 - Sidewalks 1: 0.010 ac. Disconnected Normal Silty Source Area PSD File: C:\WinSLAMM Files\NURP.cpz
45 - Large Landscaped Areas 1: 2.340 ac. Normal Silty Source Area PSD File: C:\WinSLAMM Files\NURP.cpz
57 - Undeveloped Areas 1: 1.080 ac. Normal Silty Source Area PSD File: C:\WinSLAMM Files\NURP.cpz

LU# 9 - Residential: Subarea S3 Total area (ac): 1.950
37 - Streets 1: 0.210 ac. Smooth Street Length = 0.051 mi Street Width = 33.97059 ft Street Edges = 2
Default St. Dirt Accum. Annual Winter Load = 2500 lbs Source Area PSD File: C:\WinSLAMM Files\NURP.cpz
45 - Large Landscaped Areas 1: 0.290 ac. Normal Silty Source Area PSD File: C:\WinSLAMM Files\NURP.cpz
57 - Undeveloped Areas 1: 1.450 ac. Normal Silty Source Area PSD File: C:\WinSLAMM Files\NURP.cpz

LU# 10 - Residential: Subarea E5 Total area (ac): 1.130
37 - Streets 1: 0.380 ac. Smooth Street Length = 0.0922 mi Street Width = 34.00217 ft Street Edges = 2
Default St. Dirt Accum. Annual Winter Load = 2500 lbs Source Area PSD File: C:\WinSLAMM Files\NURP.cpz
45 - Large Landscaped Areas 1: 0.310 ac. Normal Silty Source Area PSD File: C:\WinSLAMM Files\NURP.cpz
57 - Undeveloped Areas 1: 0.440 ac. Normal Silty Source Area PSD File: C:\WinSLAMM Files\NURP.cpz

Control Practice 1: Biofilter CP# 1 (DS) - Kettle 4K

1. Top area (square feet) = 247504
2. Bottom area (square feet) = 100
3. Depth (ft): 10.2
4. Biofilter width (ft) - for Cost Purposes Only: 10
5. Infiltration rate (in/hr) = 0.5
6. Random infiltration rate generation? No
7. Infiltration rate fraction (side): 1
8. Infiltration rate fraction (bottom): 1
9. Depth of biofilter that is rock filled (ft) 0
10. Porosity of rock filled volume = 0
11. Engineered soil infiltration rate: 0
12. Engineered soil depth (ft) = 0
13. Engineered soil porosity = 0
14. Percent solids reduction due to flow through engineered soil = 0
15. Biofilter peak to average flow ratio = 3.8

17. Particle size distribution file: Not needed - calculated by program
18. Initial water surface elevation (ft): 0
 - Soil Data Soil Type Fraction in Eng. Soil
 - Biofilter Outlet/Discharge Characteristics:
 - Outlet type: Broad Crested Weir
 1. Weir crest length (ft): 10
 2. Weir crest width (ft): 10
 3. Height of datum to bottom of weir opening: 2
 - Outlet type: Surface Discharge Pipe
 1. Surface discharge pipe outlet diameter (ft): 1
 2. Pipe invert elevation above datum (ft): 0.25
 3. Number of surface pipe outlets: 1

Control Practice 4: Biofilter CP# 4 (DS) - Basin 8B

1. Top area (square feet) = 15369
2. Bottom area (square feet) = 3368
3. Depth (ft): 4
4. Biofilter width (ft) - for Cost Purposes Only: 10
5. Infiltration rate (in/hr) = 0.11
6. Random infiltration rate generation? No
7. Infiltration rate fraction (side): 1
8. Infiltration rate fraction (bottom): 1
9. Depth of biofilter that is rock filled (ft) 0
10. Porosity of rock filled volume = 0
11. Engineered soil infiltration rate: 0
12. Engineered soil depth (ft) = 0
13. Engineered soil porosity = 0
14. Percent solids reduction due to flow through engineered soil = 0
15. Biofilter peak to average flow ratio = 3.8
16. Number of biofiltration control devices = 1
17. Particle size distribution file: Not needed - calculated by program
18. Initial water surface elevation (ft): 0
 - Soil Data Soil Type Fraction in Eng. Soil
 - Biofilter Outlet/Discharge Characteristics:
 - Outlet type: Broad Crested Weir
 1. Weir crest length (ft): 10
 2. Weir crest width (ft): 10
 3. Height of datum to bottom of weir opening: 3
 - Outlet type: Surface Discharge Pipe
 1. Surface discharge pipe outlet diameter (ft): 0.67
 2. Pipe invert elevation above datum (ft): 0.25
 3. Number of surface pipe outlets: 1

Control Practice 5: Biofilter CP# 5 (DS) - Basin 9B

1. Top area (square feet) = 30363
2. Bottom area (square feet) = 21774
3. Depth (ft): 3
4. Biofilter width (ft) - for Cost Purposes Only: 10
5. Infiltration rate (in/hr) = 0.5
6. Random infiltration rate generation? No
7. Infiltration rate fraction (side): 1
8. Infiltration rate fraction (bottom): 1
9. Depth of biofilter that is rock filled (ft) 0

10. Porosity of rock filled volume = 0
11. Engineered soil infiltration rate: 0
12. Engineered soil depth (ft) = 0
13. Engineered soil porosity = 0
14. Percent solids reduction due to flow through engineered soil = 0
15. Biofilter peak to average flow ratio = 3.8
16. Number of biofiltration control devices = 1
17. Particle size distribution file: Not needed - calculated by program
18. Initial water surface elevation (ft): 0
 - Soil Data Soil Type Fraction in Eng. Soil
 - Biofilter Outlet/Discharge Characteristics:
 - Outlet type: Broad Crested Weir
 1. Weir crest length (ft): 10
 2. Weir crest width (ft): 10
 3. Height of datum to bottom of weir opening: 2
 - Outlet type: Vertical Stand Pipe
 1. Stand pipe diameter (ft): 3
 2. Stand pipe height above datum (ft): 1.75

Control Practice 6: Biofilter CP# 6 (DS) - Basin 10B

1. Top area (square feet) = 20066
2. Bottom area (square feet) = 12005
3. Depth (ft): 3
4. Biofilter width (ft) - for Cost Purposes Only: 10
5. Infiltration rate (in/hr) = 0.5
6. Random infiltration rate generation? No
7. Infiltration rate fraction (side): 1
8. Infiltration rate fraction (bottom): 1
9. Depth of biofilter that is rock filled (ft) 0
10. Porosity of rock filled volume = 0
11. Engineered soil infiltration rate: 0
12. Engineered soil depth (ft) = 0
13. Engineered soil porosity = 0
14. Percent solids reduction due to flow through engineered soil = 0
15. Biofilter peak to average flow ratio = 3.8
16. Number of biofiltration control devices = 1
17. Particle size distribution file: Not needed - calculated by program
18. Initial water surface elevation (ft): 0
 - Soil Data Soil Type Fraction in Eng. Soil
 - Biofilter Outlet/Discharge Characteristics:
 - Outlet type: Broad Crested Weir
 1. Weir crest length (ft): 10
 2. Weir crest width (ft): 10
 3. Height of datum to bottom of weir opening: 2
 - Outlet type: Surface Discharge Pipe
 1. Surface discharge pipe outlet diameter (ft): 1.25
 2. Pipe invert elevation above datum (ft): 0
 3. Number of surface pipe outlets: 1

Control Practice 7: Grass Swale CP# 1 (SA) - SA Device, LU# 2 ,SA# 37

Total drainage area (acres)= 0.600
 Fraction of drainage area served by swales (ac) = 1.00
 Swale density (ft/ac) = 2833.33

Total swale length (ft) = 1700
Average swale length to outlet (ft)= 170
Typical bottom width (ft) = 2.0
Typical swale side slope (_H:1V) = 4.0
Typical longitudinal slope (ft.H/ft.V) = 0.040
Swale retardance factor: C
Typical grass height (in) = 4.0
Swale dynamic infiltration rate (in/hr)= 0.250
Typical swale depth (ft) for cost analysis (optional) = 0.0
Particle size distribution file name: Not needed - calculated by program
Use total swale length instead of swale density for infiltration calculations: True

Control Practice 8: Grass Swale CP# 2 (SA) - SA Device, LU# 4 ,SA# 37

Total drainage area (acres)= 0.350
Fraction of drainage area served by swales (ac) = 1.00
Swale density (ft/ac) = 2357.14
Total swale length (ft) = 825
Average swale length to outlet (ft)= 275
Typical bottom width (ft) = 2.0
Typical swale side slope (_H:1V) = 4.0
Typical longitudinal slope (ft.H/ft.V) = 0.030
Swale retardance factor: C
Typical grass height (in) = 4.0
Swale dynamic infiltration rate (in/hr)= 0.250
Typical swale depth (ft) for cost analysis (optional) = 0.0
Particle size distribution file name: Not needed - calculated by program
Use total swale length instead of swale density for infiltration calculations: True

Control Practice 9: Grass Swale CP# 3 (SA) - SA Device, LU# 7 ,SA# 37

Total drainage area (acres)= 0.550
Fraction of drainage area served by swales (ac) = 1.00
Swale density (ft/ac) = 2754.55
Total swale length (ft) = 1515
Average swale length to outlet (ft)= 215
Typical bottom width (ft) = 2.0
Typical swale side slope (_H:1V) = 4.0
Typical longitudinal slope (ft.H/ft.V) = 0.030
Swale retardance factor: C
Typical grass height (in) = 4.0
Swale dynamic infiltration rate (in/hr)= 0.250
Typical swale depth (ft) for cost analysis (optional) = 0.0
Particle size distribution file name: Not needed - calculated by program
Use total swale length instead of swale density for infiltration calculations: True

APPENDIX E

Soil Survey & Soil Boring Logs

Hydrologic Soil Group—Waukesha County, Wisconsin

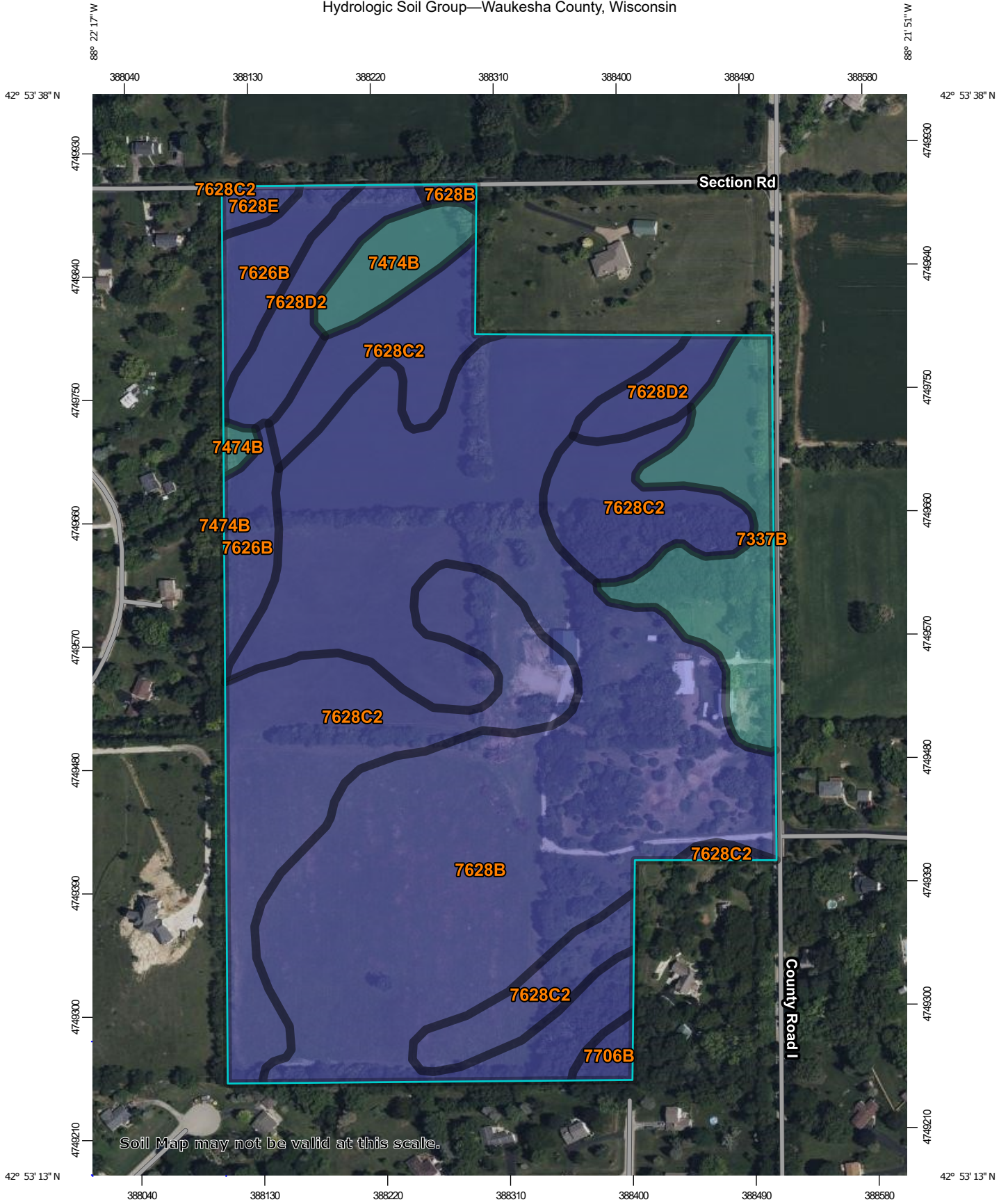

Soil Map may not be valid at this scale.

Map Scale: 1:3,840 if printed on A portrait (8.5\" x 11\") sheet.



Map projection: Web Mercator Corner coordinates: WGS84 Edge tics: UTM Zone 16N WGS84



MAP LEGEND

Area of Interest (AOI)









 Area of Interest (AOI)

Soils

Soil Rating Polygons





 A
 A/D
 B
 B/D
 C
 C/D
 D
 Not rated or not available

Soil Rating Lines

 A
 A/D
 B
 B/D
 C
 C/D
 D
 Not rated or not available

Soil Rating Points





 A
 A/D
 B
 B/D

 C
 C/D
 D
 Not rated or not available

Water Features

 Streams and Canals

Transportation

 Rails
 Interstate Highways
 US Routes
 Major Roads
 Local Roads

Background

 Aerial Photography

MAP INFORMATION

The soil surveys that comprise your AOI were mapped at 1:15,800.

Warning: Soil Map may not be valid at this scale.

Enlargement of maps beyond the scale of mapping can cause misunderstanding of the detail of mapping and accuracy of soil line placement. The maps do not show the small areas of contrasting soils that could have been shown at a more detailed scale.

Please rely on the bar scale on each map sheet for map measurements.

Source of Map: Natural Resources Conservation Service
 Web Soil Survey URL:
 Coordinate System: Web Mercator (EPSG:3857)

Maps from the Web Soil Survey are based on the Web Mercator projection, which preserves direction and shape but distorts distance and area. A projection that preserves area, such as the Albers equal-area conic projection, should be used if more accurate calculations of distance or area are required.

This product is generated from the USDA-NRCS certified data as of the version date(s) listed below.

Soil Survey Area: Waukesha County, Wisconsin
 Survey Area Data: Version 4, Sep 10, 2025

Soil map units are labeled (as space allows) for map scales 1:50,000 or larger.

Date(s) aerial images were photographed: Jul 30, 2022—Aug 18, 2022

The orthophoto or other base map on which the soil lines were compiled and digitized probably differs from the background imagery displayed on these maps. As a result, some minor shifting of map unit boundaries may be evident.

Hydrologic Soil Group

Map unit symbol	Map unit name	Rating	Acres in AOI	Percent of AOI
7337B	Fox loam, 2 to 6 percent slopes	C	4.2	7.5%
7474B	Pistakee silt loam, 1 to 3 percent slopes	C	1.6	2.9%
7626B	Miami sandy loam, sandy loam substratum, 2 to 6 percent slopes	B	2.6	4.7%
7628B	Miami loam, sandy loam substratum, 2 to 6 percent slopes	B	29.2	52.9%
7628C2	Miami loam, sandy loam substratum, 6 to 12 percent slopes eroded	B	14.1	25.6%
7628D2	Miami loam, sandy loam substratum, 12 to 20 percent slopes, eroded	B	2.9	5.2%
7628E	Miami loam, sandy loam substratum, 20 to 30 percent slopes	B	0.3	0.6%
7706B	Boyer sandy loam, 2 to 6 percent slopes	B	0.3	0.6%
Totals for Area of Interest			55.3	100.0%

Description

Hydrologic soil groups are based on estimates of runoff potential. Soils are assigned to one of four groups according to the rate of water infiltration when the soils are not protected by vegetation, are thoroughly wet, and receive precipitation from long-duration storms.

The soils in the United States are assigned to four groups (A, B, C, and D) and three dual classes (A/D, B/D, and C/D). The groups are defined as follows:

Group A. Soils having a high infiltration rate (low runoff potential) when thoroughly wet. These consist mainly of deep, well drained to excessively drained sands or gravelly sands. These soils have a high rate of water transmission.

Group B. Soils having a moderate infiltration rate when thoroughly wet. These consist chiefly of moderately deep or deep, moderately well drained or well drained soils that have moderately fine texture to moderately coarse texture. These soils have a moderate rate of water transmission.

Group C. Soils having a slow infiltration rate when thoroughly wet. These consist chiefly of soils having a layer that impedes the downward movement of water or soils of moderately fine texture or fine texture. These soils have a slow rate of water transmission.

Group D. Soils having a very slow infiltration rate (high runoff potential) when thoroughly wet. These consist chiefly of clays that have a high shrink-swell potential, soils that have a high water table, soils that have a claypan or clay layer at or near the surface, and soils that are shallow over nearly impervious material. These soils have a very slow rate of water transmission.

If a soil is assigned to a dual hydrologic group (A/D, B/D, or C/D), the first letter is for drained areas and the second is for undrained areas. Only the soils that in their natural condition are in group D are assigned to dual classes.

Rating Options

Aggregation Method: Dominant Condition

Component Percent Cutoff: None Specified

Tie-break Rule: Higher



Butler Engineering, Inc.

Soil Testing • Engineering & Safety Consulting • Safety Training

April 27, 2026

Ronald Lambert Living Trust C/O Ryan's Buying
P.O. Box 75
Hartland, WI 53029

Attn: Paul Jenswold

Subject: WDNR Infiltration Testing
Proposed Autumn Run Subdivision
SE1/4, S16, T5N, R18E
Village of Mukwonago, Waukesha Co., WI

Dear Mr. Jenswold,

We have completed soil testing for storm water infiltration at the above referenced site. Our report and conclusions regarding storm water infiltration are as follows:

Site Description

The proposed site is located on the west side of CTH "I" approximately 750' south of Section Rd. The property is bordered by residential land to the north, east, west and south.

The USDA soil map for Milwaukee and Waukesha Counties indicates that the soils on the site include Miami Loam Series Soils.

Heavy rains had occurred between April 12 and April 15, 2026.

Subsurface Exploration

Soil boring pits P1 through P6 were made on April 16 and April 17, 2026. Soils were classified in accordance with the USDA soil classification system.

Soil Saturation, seeping or standing water and redoximorphic features were noted where observed.

Free water was observed seeping in Boring P1 at nine (9) feet below surface grade (bsg) at an elevation of 959.3' approximately one (1) hour after excavation. Free water had disappeared within one half (0.5) hours of initial observation.

WDNR Infiltration Testing
Proposed Autumn Run Subdivision
April 27, 2026
Page 2 of 2

Free water was observed in Borings P5 and P6. After standing open for six (6) hours, free water had stabilized eighty-eight (88") inches (7.3') bsg at an elevation of 953.3' in P5 and after standing open for six (6) hours, free water had stabilized at ninety-six (96"), eight (8) feet bsg at an elevation of 955.2' in P6.

No water was observed in borings P2 – P4.

Conclusions

Faint high chroma mottles in gravelly sandy loam observed in Miami Loam Series soils in Waukesha County are not an indicator of sustained soil saturation.

Infiltration of storm water may be feasible in the areas tested using the soil infiltration rates listed in, Soil Infiltration Rates of the NCRS Sil Survey of Milwaukee and Waukesha Counties, Wisconsin, July 1971 (Attachment 1).

If you have any questions or concerns, please call at (262) 650-2000.

Sincerely,

Harry Butler, P.E.
Butler Engineering Inc

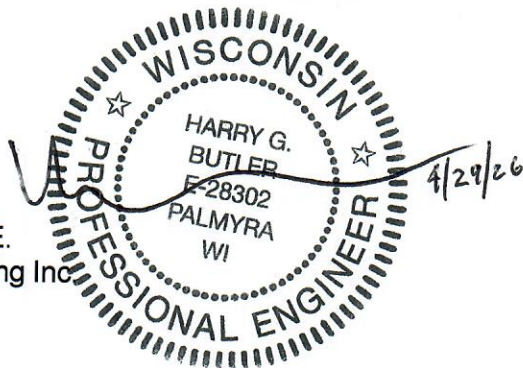

Attachment 1

Soil Infiltration Rates

NRCS Soil Survey of Milwaukee and Waukesha Counties, Wisconsin, July 1971

Soil Type	Rate (in/hr)	Infiltration Potential
Sand and gravel	>20.0	Excessively High
Sand	>20.0	Excessively High
Fine sand	>20.0	Excessively High
Gravelly loam	6.3-20.0	Very High
Loamy sand	6.3-20.0	Very High
Muck	2.0-6.3	High
Muck and peat	2.0-6.3	High
Sandy loam	2.0-6.3	High
Silt and fine sand	0.63-2.0	Moderate
Silt loam	0.63-2.0	Moderate
Silty clay loam	0.63-2.0	Moderate
Loam	0.63-2.0	Moderate
Clay loam	0.63-2.0	Moderate
Sandy clay loam	0.63-2.0	Moderate
Marl	0.63-2.0	Moderate
Sedimentary peat	0.20-0.63	Low
Silty clay	0.06-0.20	Low
Clay	0.06-0.20	Low
Dolomite	NA	Low

SOIL AND SITE EVALUATION - STORM

In accordance with SPS 382.365, 385, Wis. Adm. Code, and WDNR Standard 1002

Attach a complete site plan on paper not less than 8½ x 11 inches in size. Plan must include, but not limited to: vertical and horizontal reference point (BM), direction and percent of slope, scale or dimensions, north arrow, and BM referenced to nearest road.

County: **Waukesha**
 Parcel ID: **MUKT 1936999003**
 Reviewed by: _____ Date: _____

Please print all information

Personal information you provide may be used for secondary purposes [Privacy Law, s. 15.04(1)(m)]

Property Owner Ronald Lambert Living Trust C/O Ryan's Buying				Property Location SE¼, S16, T5N, R18E			
Property Owner's Mailing Address P.O. Box 75				Lot # Outlot 1	Block#	Subd. Name or CSM# Proposed Autumn Run	
City Hartland	State WI	Zip Code 53029	Phone Number 414 736 3066	Municipality: Village of Summit		Nearest Road: CTH I	
Drainage area _____ <input type="checkbox"/> ft. ² <input type="checkbox"/> acres Test site suitable for (check all that apply): <input type="checkbox"/> Reuse; <input type="checkbox"/> Bioretention; <input type="checkbox"/> Irrigation; <input type="checkbox"/> Subsurface Dispersal System <input type="checkbox"/> Other:				Hydraulic App. Test Method <input type="checkbox"/> Morphological Evaluation <input type="checkbox"/> Double Ring Infiltrometer <input type="checkbox"/> Other (specify):		Soil Moisture Date of soil borings: 8/31/2021 USDA-NRCS <input type="checkbox"/> Dry=1; WETS Value: <input type="checkbox"/> Normal=2; <input type="checkbox"/> Wet=3;	

P1 Boring # Boring Pit Ground Surface Elev.: 968.3 ft. Depth to Limiting Factor: 32 in.

Horizon	Depth (In.)	Dominant Color Munsell	Redox Description (Qu.Az.Cont.Color)	Texture	Structure (Gr. Sz. Sh.)	Consistence	Boundary	% Rock Frags.	% Fines	Hydraulic App. Rate (In/Hr)
1	0 - 12	7.5YR 3/2	-	sl	2vfsbk	mfr	gs	0%	15%	0.50
2	12 - 16	7.5YR 4/6	-	sl	2mfsbk	mfr	cw	0%	15%	0.50
3	16 - 32	7.5YR 4/6	-	scl	2fsbk	mfr	cs	0%	30%	0.11
4	32 - 120	7.5YR 5/4	f1f 10 YR 56	grsl	1fsbk	mfr		20%	15%	0.50
Comments: Water observed seeping @ 80" and 108" bsg										

P2 Boring # Boring Pit Ground Surface Elev.: 963.5 ft. Depth to Limiting Factor: 29 in.

Horizon	Depth (In.)	Dominant Color Munsell	Redox Description (Qu.Az.Cont.Color)	Texture	Structure (Gr. Sz. Sh.)	Consistence	Boundary	% Rock Frags.	% Fines	Hydraulic App. Rate (In/Hr)
1	0 - 8	7.5 YR 3/3	-	sl	2fsbk	mfr	cs	10%	15%	0.50
2	8 - 29	7.5YR 4/6	-	scl	2fsbk	mfr	cs	0%	30%	0.11
3	29 - 120	7.5YR 5/4	f1f 10YR 5/6	grsl	1fsbk	mfr		20%	15%	0.50
Comments: No saturation observed										

CST Name (Please Print) Harry Butler	Signature 	CST Number 222742
Address N679 Tamarack Rd. Palmyra, WI 53156	Date Evaluation Conducted 4/17/2026	Telephone Number (262) 650 - 2000

County: **Waukesha**
 Parcel ID: **MUKT 1936999003**

P3 Boring # Boring Ground Surface Elev.: Depth to Limiting Factor:
 Pit 962.9 ft. 22 in.

Horizon	Depth (In.)	Dominant Color Munsell	Redox Description (Qu.Az.Cont.Color)	Texture	Structure (Gr. Sz. Sh.)	Consistence	Boundary	% Rock Frags.	% Fines	Hydraulic App. Rate (In/Hr)
1	0 - 10	7.5YR 3/2	-	sl	2fsbk	mfr	cw	0%	15%	0.50
2	10 - 22	7.5YR 4/6	-	scl	2msbk	mfr	gw	0%	30%	0.11
3	22 - 109	7.5YR 6/4	f1f 10YR 5/6	grsl	1fsbk	mfr		20%	15%	0.50
Comments: Soil saturated @ 60"bsg, no seeping										

P4 Boring # Boring Ground Surface Elev.: Depth to Limiting Factor:
 Pit 964.4 ft. 38 in.

Horizon	Depth (In.)	Dominant Color Munsell	Redox Description (Qu.Az.Cont.Color)	Texture	Structure (Gr. Sz. Sh.)	Consistence	Boundary	% Rock Frags.	% Fines	Hydraulic App. Rate (In/Hr)
1	0 - 12	7.5YR 3/2	-	sl	2fsbk	mfr	cw	0%	15%	0.50
2	12 - 38	7.5YR 4/6	-	scl	2msbk	mfr	gw	0%	30%	0.11
3	38 - 110	7.5YR 6/4	f1f 10YR 5/6	grsl	1fsbk	mfr		20%	15%	0.50
Comments: Soil saturated @ 60"bsg, no seeping										

P5 Boring # Boring Ground Surface Elev.: Depth to Limiting Factor:
 Pit 960.6 ft. 30 in.

Horizon	Depth (In.)	Dominant Color Munsell	Redox Description (Qu.Az.Cont.Color)	Texture	Structure (Gr. Sz. Sh.)	Consistence	Boundary	% Rock Frags.	% Fines	Hydraulic App. Rate (In/Hr)
1	0 - 14	7.5YR 3/2	-	sl	2fsbk	mfr	cs	0%	15%	0.50
2	14 - 36	7.5YR 4/4	-	scl	2msbk	mfr	gs	0%	30%	0.11
3	36 - 50	7.5YR 5/3	none	grscl	1fsbk	mfr	gw	10%	30%	0.11
4	50 - 68	10 YR 6/4	saturated	grsl	0m	mfr	gs	20%	15%	0.50
5	68 - 92	10 YR 6/4	m2d 10 YR 5/8. 6/2	grls	0sg	mfr	gs	20%	10%	1.63
6	92 - 112	10 YR 6/4	f1f 10 YR 5/8	grls	0m	mfr		20%	5%	1.63
Comments: Water ponded @ 88" after 6 hrs										

W. LINE OF THE SE 1/4 OF THE SW 1/4
OUTLOT

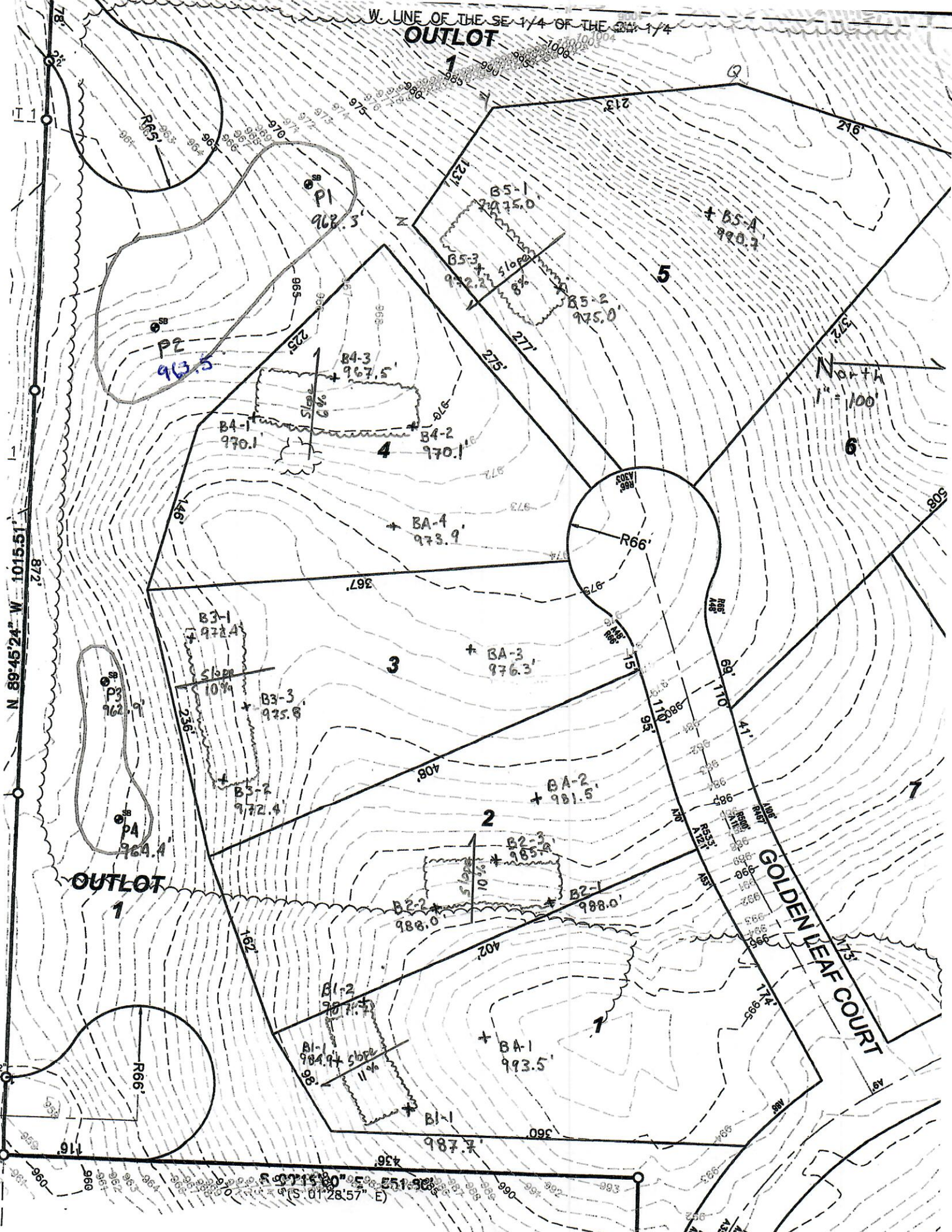

N 89°45'24" W 1015.51'
872'

OUTLOT
1

GOLDEN LEAF COURT

S 97°15'30" E 551.90'
(S 01°28'57" E)

