

PLAN COMMISSION REPORT

Proposal: Sign Appeal – Oak Creek Farmers Market

Description: Request for a variance to allow for a temporary sign to be greater than 72 inches in height and displayed in excess of 44 days for the Oak Creek Farmers Market at 361 W. Town Square Way.

Applicant(s): Renee Wallace, Oak Creek Farmers Market

Address(es): 361 W. Town Square Way (2nd Aldermanic District)

Motion for Consideration: That the Plan Commission approves the sign variance allowing a temporary sign 94 inches in height to be displayed for 192 days on the property at 361 W. Town Square Way with conditions.

Owner(s): City of Oak Creek

Tax Key(s): 813-9032-000

Lot Size(s): 1.055 ac

Current Zoning District(s): DTSMUPDD

Overlay District(s): N/A

Wetlands: Yes No **Floodplain:** Yes No

Comprehensive Plan: Mixed-Use

Background: The Appellant is requesting a variance to allow a temporary sign 94 inches in height to be displayed for 192 days on the property at 361 W. Town Square Way. The location is within the northwest corner of the Town Square itself for a 72” x 48” (24 sf) aluminum sign face with rigid vinyl posts and frame measuring 94” in height, with a 1.5’ x 6’ hanging sign between the posts for an additional event to be displayed below the main sign face. Plan Commissioners will recall that this sign was reviewed and approved for temporary installation in May of 2023, 2024, and 2025.

The Appellant is requesting a variance from the following Municipal Code Sections:

- Section 17.0605(a)(1), stating that the maximum display period for temporary signs in non-residential districts is 14 continuous days, with a maximum of three (3) display periods. The Community Development Director or their designee may grant a display period extension of up to 30 days, allowing for a single display period of up to 44 days.
 - o The Appellant is requesting a display period of 192 days from April 15, 2026 through October 24 2026.
- Section 17.0605(d)(2), stating that the maximum permitted height of a ground-mounted sign is six feet (72 inches).
 - o The proposed sign is seven feet and 10 inches (94 inches).

The proposed end date for the permit is October 24, 2026, with a removal deadline of October 28, 2026.

Decisions to approve a variance must be made utilizing the following criteria:

1. Special conditions exist which will cause practical difficulty or unnecessary hardship if the variance requested is not granted.
2. The variance requested is not contrary to the public interest and will not endanger public safety and welfare.
3. The variance requested will be in accord with the spirit of the zoning ordinance.
4. The variance, if granted, will cause substantial justice to be done.
5. Variance considerations shall include determinations as to conformance to Sec. 17.607, General Sign Regulations.

Motion for Consideration: That the Plan Commission approves the sign variance allowing a temporary sign 94 inches in height to be displayed for 192 days on the property at 361 W. Town Square Way.

1. That all relevant Code and DTSMPDD requirements remain in effect.
2. That one (1) 72" x 48" (24 sf sign face) x 94" (h) temporary ground sign with one (1) 1.5' x 6' attached hanging sign is approved in the location shown on the approved site plan. Sign shall be installed a minimum of 10 feet from property lines and rights-of-way.
3. That the Temporary Sign Permit shall be valid through October 24, 2026. The sign shall be removed by October 28, 2026.

Options/Alternatives: The Plan Commission has the discretion to approve plans as presented, approve with specified conditions, or disapprove the proposal. Should the request not be approved, Plan Commissioners must provide the Code Sections upon which the denial is based so that the Appellant may revise and resubmit (if necessary).

Respectfully submitted & approved by:



Kristi Laine
Community Development Director

Prepared by:



Nic D'Amato
Planner

Attachments:

- Location Map
- Site Plan (1 page)
- Sign Details (1 page)
- Sign Graphics (1 page)

Location Map

361 W. Town Square Way



This map is not a survey of the actual boundary of the property this map depicts

Legend

- Zoning
- Official Street Map
- Parcels
- FloodFringe2024
- Floodway2024
- 361 W Town Sq Way

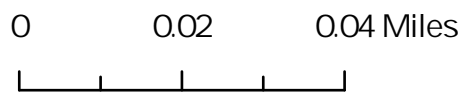

- OAK CREEK -
**FARMERS
MARKET**

DREXEL TOWN SQUARE

Drexel Town Square Sign proposal

Creating a professional looking
semi-permanent sign holder to upgrade the
banner look from years past.

Placed in
planting
bed

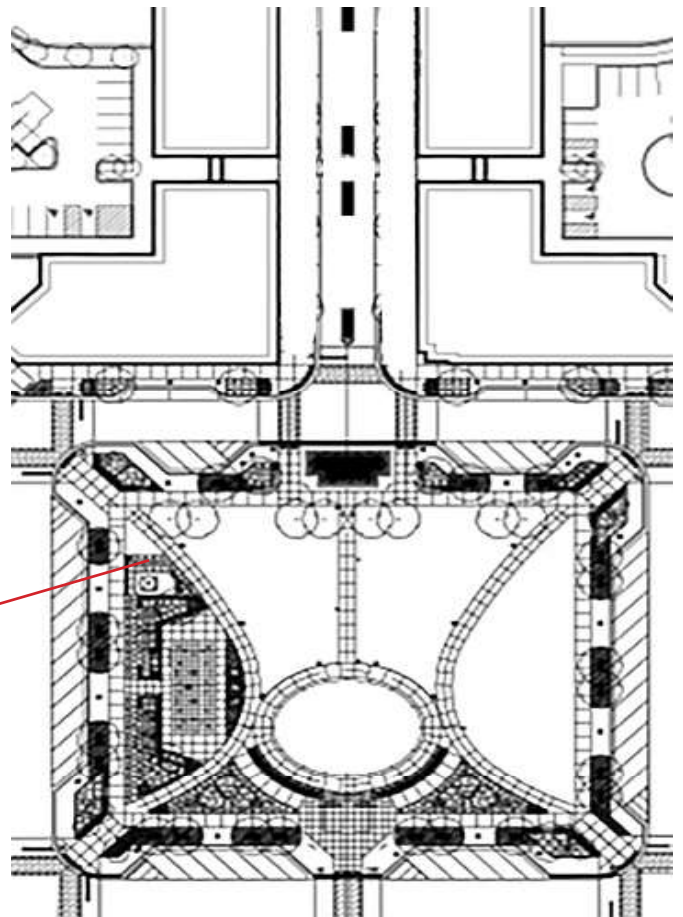

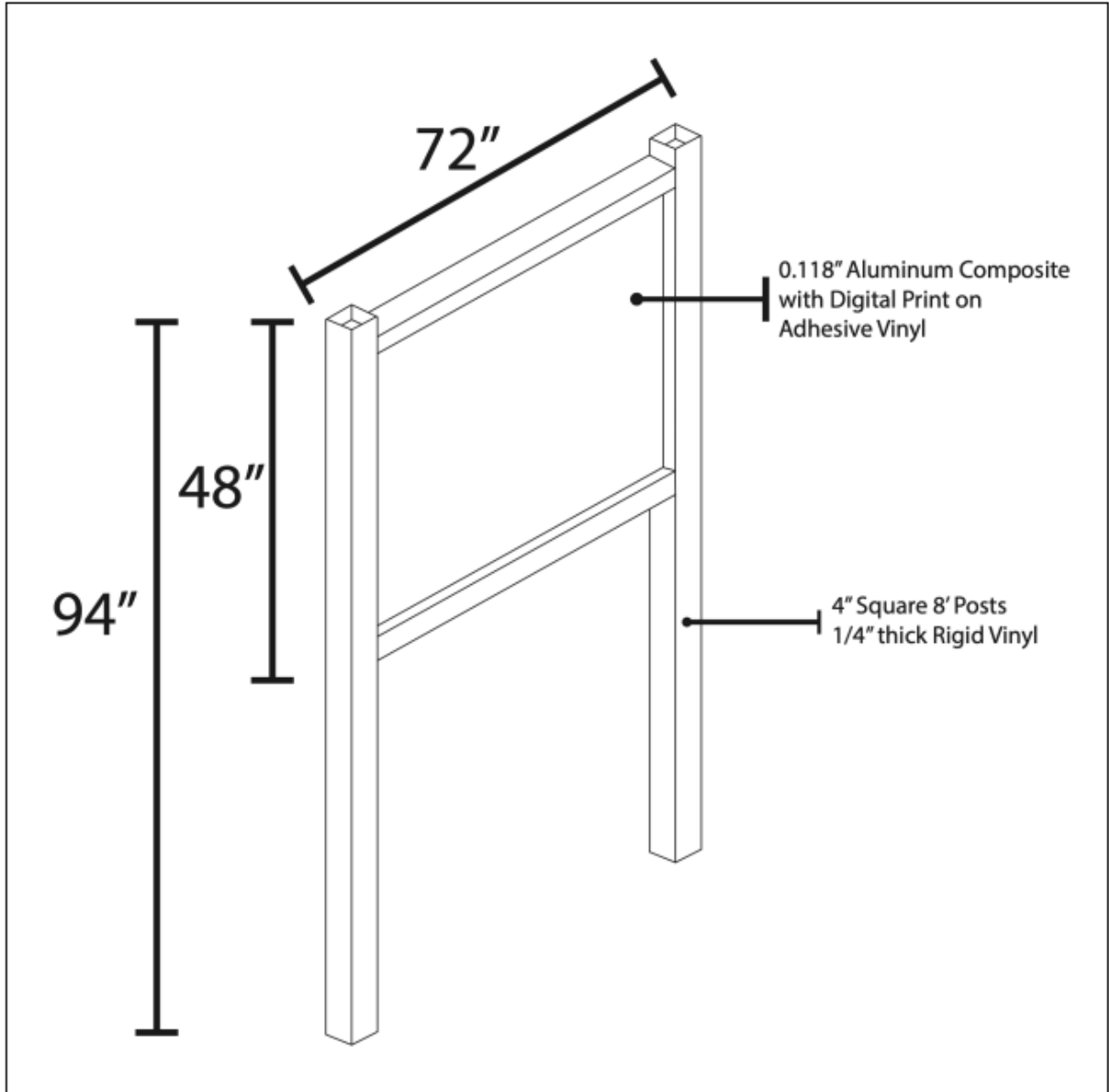



OAK CREEK

FARMERS MARKET

DREXEL TOWN SQUARE

SATURDAYS, 9AM-1PM

2023 MARKET SPONSORS

AZURA
MEMORY CARE • ASSISTED LIVING

MARTIN
LAW OFFICE, S.C.

Educators
CREDIT UNION

SAVAGLIA
FINANCIAL ADVISORS

IBEW Local 494
Construction Workers